

# II. Energy Days Symposium

September 26-27, 2023, / Sivas Cumhuriyet University, Türkiye



## PROCEEDINGS BOOK

EDITORS

Assist. Prof. Dr. Derya Betül UNSAL  
Atabek MOVLYANOV

ISBN: 978-625-367-369-7  
by IKSAD Publishing House

# II. Energy Days Symposium

September 26-27, 2023, / Sivas Cumhuriyet University, Türkiye

## PROCEEDINGS BOOK

### EDITORS

Assist. Prof. Dr. Derya Betül UNSAL  
Atabek MOVLYANOV

by  
IKSAD PUBLISHING HOUSE®

All rights of this book belong IKSAD Publishing House  
Authors are responsible both ethically and juridically  
IKSAD Publications – 2023©  
Issued: 23.10.2023

**ISBN: 978-625-367-369-7**

# SYMPOSIUM ID

## **SYMPOSIUM TITLE**

II. Energy Days Symposium

## **DATE and PLACE**

September 26-27, 2023 / Sivas Cumhuriyet University, Türkiye

## **PARTICIPATION**

Keynote & Invited

## **ORGANIZATION**

Renewable Energy Research Center Sivas Cumhuriyet University, Türkiye  
Sustainability Office, Sivas Cumhuriyet University, Türkiye  
IKSAD-Institute of Economic Development and Social Research, Türkiye

## **PARTICIPANTS COUNTRY**

Türkiye, Azerbaijan, Algeria, Iran, Libya, Palestine, India, Vietnam, Pakistan, Nigeria,  
Romania, Bangladesh, Austria, Morocco, Indonesia

Number Of Accepted Papers-**78**

Number Of Rejected Papers-**14**

The number of abstracts from foreign countries-**40**

The number of abstracts from Türkiye-**38**

## SYMPOSIUM HONORARY CHAIR

**Prof. Dr. Alim YILDIZ**  
Sivas Cumhuriyet University Rector

## SYMPOSIUM GENERAL CHAIR

**Prof. Dr. Hilmi ATASEVEN**, Vice Rector of Sivas Cumhuriyet University  
**Prof. Dr. Hakan YEKBAŞ**, Vice Rector of Sivas Cumhuriyet University

## SYMPOSIUM LOCAL COMMITTEE CHAIR

**Prof. Dr. Nevcihan GÜRSOY**, Sivas Cumhuriyet University, Turkey

## TECHNICAL PROGRAM COMMITTEE CHAIRS

**Prof. Dr. Taha Selim USTUN**, Fukushima Renewable Energy Institute, Japan  
**Prof. Dr. Ahmet ONEN**, Sultan Qaboos University, Oman  
**Prof. Dr. Tülay YILDIRIM**, Yıldız Technical University, Turkey  
**Prof. Dr. S. M. MUYEEN**, Curtin University, Australia  
**Assist. Prof. Dr. Arman JALALI**, Tabriz University, Iran

## SYMPOSIUM ADVISORY CHAIR

**Prof. Dr. Meltem SARIOĞLU CEBEÇİ**, Sivas Cumhuriyet University, Turkey

## SYMPOSIUM ORGANIZING COMMITTEE CHAIR

**Assist. Prof. Dr. Derya Betül UNSAL**  
Director of Renewable Energy Research Center and Coordinator of Sustainability Office in Sivas Cumhuriyet University, Turkey

## SYMPOSIUM ORGANIZING COMMITTEE

**Assoc. Prof. Dr. Sultan ERKAN**, Vice Director of Renewable Energy Research Center, Sivas Cumhuriyet University, Turkey  
**Assist. Prof. Dr. Ahmet AKSOZ**, Sivas Cumhuriyet University, Turkey  
**Assist. Prof. Dr. Yeliz YOLDAS**, Kayseri University, Turkey

## VIRTUAL PLATFORM CHAIR

**Ayhan OZDEMIR**, Sivas Cumhuriyet University, Turkey

## SYMPOSIUM COORDINATORS

**M.Sc. Atabek MOVLYANOV**  
**M.Sc. Zeynep CERAN ÇAMAYAZ**

# SCIENTIFIC BOARD MEMBERS

- Prof. Dr. Adel MERABET, Saint Mary's University, Halifax, NS, Canada  
Prof. Dr. Abdulkerim YÖRÜKOĞLU, Sivas Cumhuriyet University, Turkey  
Prof. Dr. Ahmet ONEN, Sultan Qaboos University, Oman  
Prof. Dr. Ahmet Afşin KULAKSIZ, Konya Technical University, Turkey  
Prof. Dr. Bernie L.DAHL, Purdue University, U.S.A.  
Prof. Dr. Beliz OZORHON, Boğaziçi University, Turkey  
Prof. Dr. Claudia JUROWSKI, Northern Arizona University, U.S.A.  
Prof. Dr. Dani SARSEKOVA, Wildlife and the Environment of S.Seifullin Kazakh Agrotechnical University, Kazakhstan  
Prof. Dr. Fuat ÖZYONAR, Sivas Cumhuriyet University, Turkey  
Prof. Dr. Harpreet KAUR, Mata Sundri College for Women, University of Delhi, India  
Prof. Dr. Hüseyin ÇANBOLAT, Yıldırım Beyazıt University, Turkey  
Prof. Dr. Meltem SARIOĞLU CEBECİ, Sivas Cumhuriyet University, Turkey  
Prof. Dr. Nevcihan GÜRSOY, Sivas Cumhuriyet University, Turkey  
Prof. Dr. Nuri AZBAR, Ege University, Turkey  
Prof. Dr. Rashmi GUJRATİ, CT University, India  
Prof. Dr. Serkan AKKOYUN, Sivas Cumhuriyet University, Turkey  
Prof. Dr. S. M. Muyeen, Curtin University, Australia  
Prof. Dr. Tuncay BAYRAM, Karadeniz Teknik University, Turkey  
Prof. Dr. Tülay YILDIRIM, Yıldız Technical University, Turkey  
Prof. Dr. Ümit ERDEM, Aegean University, Greece  
Prof. Dr. Ümit YILMAZ, University of Georgia, Georgia  
Assoc. Prof. Dr. Ahmet Gürkan YÜKSEK, Sivas Cumhuriyet University, Turkey  
Assoc. Prof. Dr. Bülent ÜNVER, Sivas Cumhuriyet University, Turkey  
Assoc. Prof. Dr. Enis Baha BİÇER, Sivas Cumhuriyet University, Turkey  
Assoc. Prof. Dr. Guguli DUMBADZE, Batumi Shota Rustaveli State University, Georgia  
Assoc. Prof. Dr. Koray SAYIN, Sivas Cumhuriyet University, Turkey  
Assoc. Prof. Dr. Maira KUSSAINOVA, Kazakh National Agrarian Research University, Kazakhstan  
Assoc. Prof. Dr. Meryem ŞEFERİNOĞLU, Sinop University, Turkey  
Assoc. Prof. Dr. Murat FAHRİOĞLU, Middle East Technical University, Turkey  
Assoc. Prof. Dr. Murat ORAL, Konya Technical University, Turkey  
Assoc. Prof. Dr. Sultan ERKAN, Sivas Cumhuriyet University, Turkey  
Assist. Prof. Dr. Arman JALALI, Tabriz University, Iran  
Assist. Prof. Dr. Ahmet AKSOZ, Sivas Cumhuriyet University, Turkey  
Assist. Prof. Dr. Hüseyin ŞAHİNER, Sinop University, Turkey  
Assist. Prof. Dr. Mustafa ŞEKER, Sivas Cumhuriyet University, Turkey  
Assist. Prof. Dr. Nurperihan TOSUN, Sivas Cumhuriyet University, Turkey  
Assist. Prof. Dr. Şeyma TAŞTEMUR, Sivas Cumhuriyet University, Turkey  
Assist. Prof. Uzma NADEEM, Mata Sundri College for Women, University Of Delhi  
Assist. Prof. Dr. Yeliz YOLDAŞ, Kayseri University, Turkey  
Assist. Prof. Dr. Yunis TORUN, Sivas Cumhuriyet University, Turkey  
Assist. Prof. Dr. Dr. Zeynep HASIRCI TUĞÇU, Karadeniz Technical University, Turkey  
Dr. Barış SANLI, Bilkent University, Turkey  
Dr. Nermin KIBRISLIOĞLU UYSAL, Boston, Massachusetts, U.S.A.  
Dr. Mariana GOLUMBEANU, National Institute for Marine Research "Grigore Antipa", Romania  
Dr. Şeyda MAHARRAMOVA, Azerbaijan Food Safety Institute, Azerbaijan  
Dr. Şeyma KIBRISLIOĞLU BAYKAN, İzmir Research Hospital, Turkey

# PHOTO GALLERY

The image shows a Zoom meeting interface with a grid of participants and a shared PowerPoint slide. The participants are arranged in a 5x5 grid. The top row includes Arman Jalali, Atabek Movlyanov, Hall-2, Fazil Çabarov, and Dr. Derya Betül Unsul. The second row includes Hall-3, Session-1, Dr. Neslihan AYDIN, Hall-2, Tuba Artan Onat, Hall-1, Halil Çeçen, Hall-5, Session-2, PURUSHOTTAM KUM., and Meltem Sanoglu Cebeci. The third row includes Hall-2, Session-1, Sami Melik, Mustafa ÖZCAN, Hall-3, Yasmine..., Hall-5, Session 1, Selda Tözüm, and Dr Badis Bakri. The fourth row includes OBSERVER H-1 ÜLKÜ, Dr.Badis Bakri\_Hall\_3, h2-observer-Merve KIDIRYÜZ, h3-observer-Merve, and Arman celali (university of Tabriz, Iran). The fifth row includes ZOOM, Melisa, Hall-3, Hasan Yepilyurt, Hall-3, Session-2, Ahmet Şakir Dokuz, and Hall 5 Observer. The shared PowerPoint slide is titled "ENERGY DAYS" and features the logos of Sivas Cumhuriyet University and the Faculty of Engineering. The slide content is: "ENERGY GENERATION FROM THE ANAEROBIC STABILIZATION OF SEWAGE SLUDGE AND DOMESTIC WASTES (METHANE PRODUCTION)" by Meltem SARIOĞLU-CEBECİ, 1<sup>st</sup> Sivas Cumhuriyet Üniversitesi Mühendislik Fakültesi Çevre Mühendisliği Bölümü, TR-58140, SIVAS, sarioglu@cumhuriyet.edu.tr. The slide number is 2.

The image shows a Zoom meeting interface. The top part displays a grid of seven participants: Hall-1 Şener İller, OBSERVER ÜLKÜ H-1, Hall-1 Umut Ercan, Hall-1 Başak Öztürk, Dr. Öğretim Üyesi Pınar Buket Kılıç Pala, Serdar Erdoğan, and Hasret Kaya. The bottom part shows a shared presentation slide titled "GÜNEŞ ENERJİSİ TAHMİNİ VE DEĞERLENDİRİLMESİ". The slide content is as follows:

## GÜNEŞ ENERJİSİ TAHMİNİ VE DEĞERLENDİRİLMESİ

- Güneş enerjisi potansiyelinin tahmin edilmesi, belirli bir yer ve zaman aralığındaki güneş enerjisi miktarını tahmin etme işlemi olarak tanımlanabilir.
- Fotovoltaik paneller gibi güneş enerjisi sistemleri elektrik üretmek için güneş ihtiyacı duymaları nedeniyle ürettikleri enerji miktarı günün saati, bulut örtüsü ve güneşin açısı gibi faktörlere bağlı olarak değişebilir. Bu da bir yatırım planı yapılırken enerji potansiyelinin tahmin edilmesinin ne kadar önemli olduğunu göstermektedir.

Kaydediliyor... Hall 2- Tuba Artan Onat ekranını görüntüyorsunuz Seçenekleri Görüntüle Giriş yapın Görüntüle



**A NEW APPROACH  
TO WASWATER TREATMENT:  
MICROBIAL FUEL CELLS**

Tuba ARTAN ONAT, İlknur ERKİLİNÇ  
Niğde Ömer Halisdemir University  
Faculty of Science and Arts  
Department of Biotechnology

Hall 2- Tuba Artan Onat

Sesi aç Videoyu Başlat Katılımcılar 17 Sohbet Ekranı paylaş Kaydı Duraklat/Durdur Ara Odalar Reaksiyonlar Uygulamalar Beyaz Tahtalar Odadan Çık

Kaydediliyor... Hall-2, Isaac Jato PowerPoint'ini görüntüyorsunuz Seçenekleri Görüntüle Giriş yapın

**OPTIMIZATION OF LINEAR ALKYL BENZENE YIELD USING DESIGN EXPERT®**

***A CONFERENCE PAPER***

by

**Isaac JATO**

isaacjato620@gmail.com

Federal Polytechnic N'yak Shendam Plateau State Nigeria

**Ahmed Mohammed INUWA**

aminuwa.pg@atbu.edu.ng,

Abubakar Tafawa Balewa University P.M.B 0247, Bauchi  
Nigeria

**Habibu Abubakar WANIYO**

habibuabubakarwaniyo@gmail.com

Federal Polytechnic Kaltungo Gombe State Nigeria

***Presented to:***

**II INTERNATIONAL ENERGY DAYS AT SIVAS CUMHURİYET UNIVERSITY TURKEY**

**SEPTEMBER 27TH, 2023**

Sesi aç Videoyu Başlat Katılımcılar 6 Sohbet Ekranı paylaş Kaydı Duraklat/Durdur Ara Odalar Reaksiyonlar Uygulamalar Beyaz Tahtalar Odadan Çık



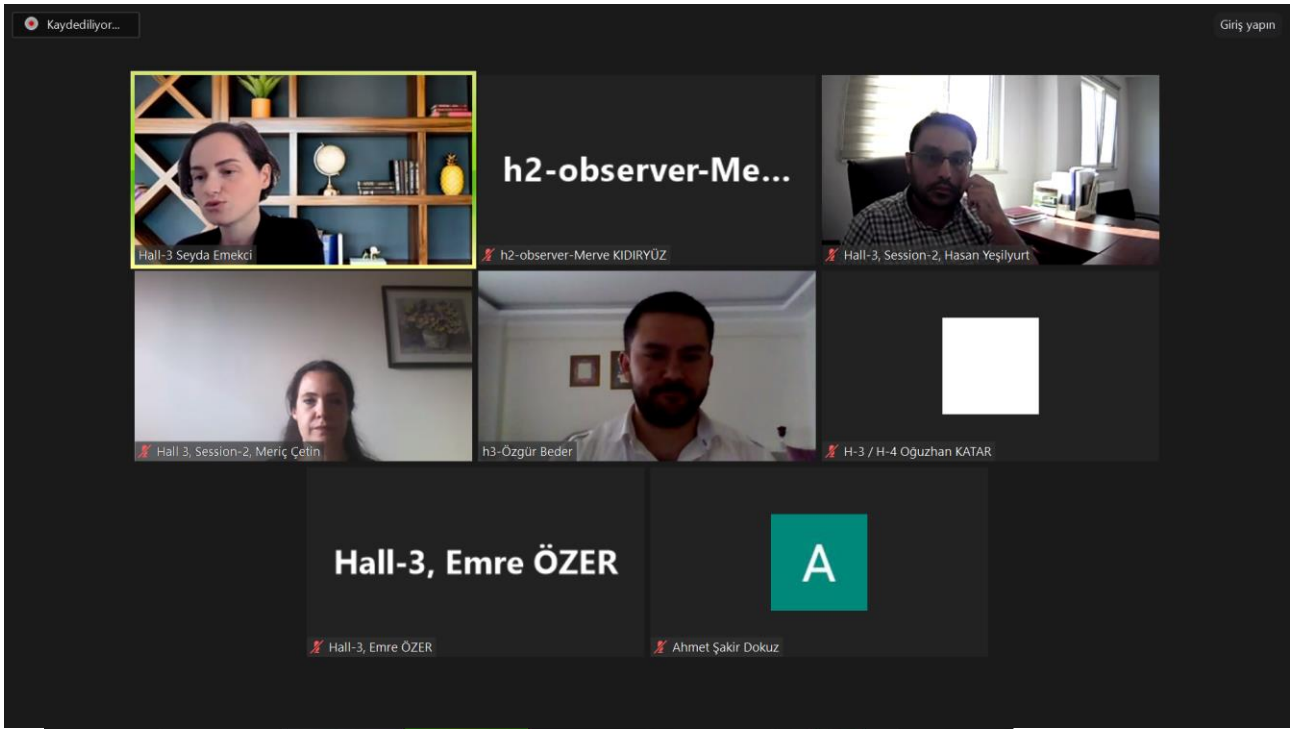

Hall 4 Observer Moderator: Hall-1, H... TOUMI Meriem Hall-4-Dr Rozina Khattak Harminder Singh İftikhar Yasin

Kaydediliyor... Giriş yapın

## Estimating CH<sub>4</sub> Emission from Blida Landfill

Municipal landfills are the major contributors to the emission of greenhouse gases. Our study uses LandGem model to predict the CH<sub>4</sub> emission from Blida landfill and explore how to convert it into electricity.

2 atanmamış katılımcı

Sesi aç Videoyu Başlat Katılımcılar Sohbet Ekranı paylaş Kaydı Duraklat/Durdur Ara Odalar Reaksiyonlar Uygulamalar Odadan Çık

Katılımcılar (6)

- H4 H.. (Ortak oturum sahibi, ben)
- TM TOUMI Meriem
- HR Hall-4-Dr Rozina Khattak
- HS Harminder Singh
- İY İftikhar Yasin
- MH Moderator: Hall-1, Halil Çeçen

Tümünü Sessize Al

**NUMERICAL INVESTIGATION OF VARIOUS MOTHER-FIN LENGTHS FOR T-SHAPED FINS ON THE MELTING PROCESS**

**İsmail DEMİRKİRAN**  
Research Assistant, İzmir Institute of Technology (IZTECH), Faculty of Engineering, Department of Mechanical Engineering, İzmir-Türkiye  
[ismaildemirkiran@iyte.edu.tr](mailto:ismaildemirkiran@iyte.edu.tr), (Responsible Author) ORCID: 0000-0003-4620-5514, +905061619499

**Erdal ÇETKİN**  
Prof. Dr., İzmir Institute of Technology (IZTECH), Faculty of Engineering, Department of Mechanical Engineering, İzmir-Türkiye  
[erdalçetkin@iyte.edu.tr](mailto:erdalçetkin@iyte.edu.tr), ORCID: 0000-0003-3686-0208, +905383570747

Sivas, TÜRKİYE  
27.09.2023

**THE IMPACT OF INCREASING FUEL PRICES ON FAMILY BUDGET IN INDONESIA**

Kaydediliyor...

Hall 5 Observ... Hall-5, Chou...

Microsoft PowerPoint - presentation.pptx

## II. INTERNATIONAL ENERGY DAYS

Sivas Cumhuriyet University Wednesday,  
September 27th, 2023

### SOLAR PUMPING SYSTEM BASED ON AN INDUCTION MOTOR

Presented by : CHOUHA Youcef

And: Beladel Abdelkader  
Kouzou Abdellah  
Douara Ben ouadeh  
Karboua Djalous  
Mebkhouta Toufik

II. INTERNATIONAL ENERGY DAYS

Katılımcılar (12)

Ara

- H5 Hall 5... (Ortak oturum sahibi, ben)
- H Hall-5, Chouha Youcef
- HS Hall-5, Session-2 , PURUSHOTTAM...
- M Moderator : Cemil Alkan
- Bahadır Erman YÜCE
- DY Demet Yılmaz
- HS Hall-5, Sena Demirbağ Genç
- Hall-5, Session 1, Selda Tözüm
- Hall-5,Djaloul Karboua
- Mh Melisa, hall-5
- SA Sennur Alay Aksoy
- SS Suleyman SISMAN

Tümünü Sessize Al Daha fazla

Kaydediliyor...

Hall 5 Observer

Hall-5, Chouha Y...

Melisa, hall-5

Sennur Alay Aksoy

Suleyman SISMAN

Demet Yılmaz





Hall-5, Sena Demi...

Katılımcılar (12)

Ara

- H5 Hall 5... (Ortak oturum sahibi, ben)
- M Moderator : Cemil Alkan
- Bahadır Erman YÜCE
- DY Demet Yılmaz
- H Hall-5, Chouha Youcef
- HS Hall-5, Sena Demirbağ Genç
- Hall-5, Session 1, Selda Tözüm
- HS Hall-5, Session-2 , PURUSHOTTAM...
- Hall-5,Djaloul Karboua
- Mh Melisa, hall-5
- SA Sennur Alay Aksoy
- SS Suleyman SISMAN

Tümünü Sessize Al Daha fazla

Hall 5 Observ...     Hall-5, Chou... >

Kaydediliyor...

# CONVENTIONAL AND ADVANCED EXERGY ANALYSIS OF A RANKINE CYCLE

**Assist. Prof. Dr. Bahadır Erman YÜCE**  
Bitlis Eren University, Mechanical Engineering Department



























 2023-II. International Energy Days Symposium

Kaydediliyor...

Katılımcılar (12)

Q Ara

- H5 Hall 5... (Ortak oturum sahibi, ben)  
- Bahadır Erman YÜCE  
- M: Moderator : Cemil Alkan  
- DY Demet Yılmaz  
- H Hall-5, Chouiha Youcef  
- HS Hall-5, Sena Demirbağ Genç  
- Hall-5, Session 1, Selda Tözüm  
- HS Hall-5, Session-2 , PURUSHOTTAM...  
- Hall-5, Djaloul Karboua  
- Mh Melisa, hall-5  
- SA Sennur Alay Aksoy  
- SS Suleyman SISMAN  

Tümünü Sessize Al Daha fazla

# MODIFIED TRI-STATE STEP-UP CONVERTER WITH COUPLED COILS

**Felix A. HIMMELSTOSS**

University of Applied Sciences, Faculty of Electronic Engineering and  
Entrepreneurship, Power Electronics Section,  
Vienna, Austria



Hall 4 Observer





# II. INTERNATIONAL ENERGY DAYS

Sivas Cumhuriyet University  
Wednesday, September 27<sup>th</sup>, 2023

## Symposium Programme

Meeting ID: 871 0713 9228

Passcode: 272727

### Important, Please Read Carefully

- To be able to attend a meeting online, login via <https://zoom.us/join> site, enter ID "Meeting ID or Personal Link Name" and solidify the session.
- The Zoom application is free and no need to create an account.
- The Zoom application can be used without registration.
- The application works on tablets, phones and PCs.
- The participant must be connected to the session 5 minutes before the presentation time.
- All congress participants can connect live and listen to all sessions.
- Moderator is responsible for the presentation and scientific discussion (question-answer) section of the session.

### Points to Take into Consideration - TECHNICAL INFORMATION

- Make sure your computer has a microphone and is working.
- You should be able to use screen sharing feature in Zoom.
- Attendance certificates will be sent to you as pdf at the end of the congress.
- Requests such as change of place and time will not be taken into consideration in the congress program.

\*\*\*

Before you login to Zoom please indicate your hall number, name and surname

**exp. Hall-1, Ethem KILIÇ**

# - Welcome Greetings -

Date- 27.09.2023

All schedule is according to GMT +3 time zone (Istanbul)

**Assist. Prof. Dr. Derya Betul UNSAL- (12.00-12.10)**

Director of Renewable Energy Research Center and  
Coordinator of Sustainability Office in Sivas Cumhuriyet University, Turkiye  
**Symposium Organizing Committee Chair**

---

**Prof. Dr. Meltem SARIOĞLU CEBECİ- (12.10-12.30)**

Sivas Cumhuriyet University, Turkiye  
"Organik atıklar ve arıtma çamurlarının anaerobik parçalanması ile Enerji (biyogaz) Üretimi"

---

**Assist. Prof. Dr. Arman JALALI (12.30-12.50)**

Tabriz University, Iran  
"Biohydrogen: A Sustainable and Promising Energy Source (production, storage and transportation)"

**27.09.2023 / Hall-1, Session-1 / TSI Time - 13<sup>00</sup>:15<sup>00</sup>**



**Zoom ID: 871 0713 9228 / Passcode: 272727**



**Moderator: Assist. Prof. Dr. Halil Cecen**

<b>Authors</b>	<b>Affiliation</b>	<b>Presentation title</b>
<b>Assist. Prof. Dr. Halil Cecen</b>	Nuh Naci Yazgan University, Türkiye	REVIEW OF THE CURRENT DEVELOPMENTS REGARDING THE INVESTMENTS IN OFFSHORE WIND ENERGY IN TURKIYE WITHIN THE FRAMEWORK OF THE RENEWABLE ENERGY POLICY OF THE EUROPEAN UNIO
<b>Assist. Prof. Dr. Halil Cecen</b>	Nuh Naci Yazgan University, Türkiye	"COVENANT OF COMPANIES FOR CLIMATE AND ENERGY" AS A NEW PILOT INITIATIVE IN THE EUROPEAN UNION REGARDING THE CONTRIBUTIONS OF COMPANIES TO COMBATING CLIMATE CHANGE
<b>Oussama MOUSS Lallouani HELLALI Riyadh ROUABH Aboubaker Essadiq MAZOUZ Ali BOUZIDI Ali AKKA</b>	University of M'sila, Algeria University of Tiaret, Algeria Higher Normal School of Boussada, Algeria	ROBUST NONLINEAR CONTROL VIA FEEDBACK LINEARIZATION AND LYAPUNOV THEORY FOR BRUSHLESS DOUBLY FED INDUCTION GENERATOR BASED ON WIND ENERGY CONVERSION SYSTEM
<b>Halali Youcef Ghaitaoui Touhami Ouledali Omar Ghaitaoui Ahmed Essama</b>	Université d'Adrar, Algeria	SLIDING MODE BASED P&O MPPT FOR SOLAR PV SYSTEM

27.09.2023 / Hall-2, Session-1 / TSI Time - 13<sup>00</sup>:15<sup>00</sup>



Zoom ID: 871 0713 9228 / Passcode: 272727



Moderator: Assist. Prof. Arman Jalali

Authors	Affiliation	Presentation title
Assist. Prof. Arman Jalali	University of Tabriz, Iran	THE IMPORTANCE OF RENEWABLE ENERGY STORAGE FOR A SUSTAINABLE FUTURE
Assist. Prof. Dr. Hüseyin Utku HELVACI Mehmet Süha İşi	Dogus University, Türkiye	ONE DIMENSIONAL AND THREE DIMENSIONAL THERMAL ANALYSIS OF AN AIR-COOLED PEM FUEL CELL
Assist. Prof. Dr. Tuba ARTAN ONAT İlknur ERKİLİNÇ	Niğde Ömer Halisdemir University, Türkiye	A NEW APPROACH TO WASTEWATER TREATMENT: MICROBIAL FUEL CELLS
Furkan BAŞ Öznur Begüm GÖKÇEK Hamdi MURATÇOBANOĞLU Sevgi DEMİREL	Niğde Ömer Halisdemir University, Türkiye	SUSTAINABLE ALGAL BIOECONOMY FOR BIOFUEL
Assoc. Prof. Dr. Cəfərov Fazil Tatarxan oğlu Assoc. Prof. Dr. Məmmədov Sabir Rüstəm oğlu	Azerbaijan State Pedagogical University, Azerbaijan	ALTERNATIVE ENERGY AND ITS USE IN AZERBAIJAN
Prof. Dr. Meltem SARIOĞLU CEBECİ	Sivas Cumhuriyet University, Türkiye	BİTKİSEL YAĞLARDAN BİYODİZEL ELDESİ VE DEĞERLENDİRİLMESİ
Abdussalam Ali Ahmed Abdulgader Alsharif Mohammed Khaleel Yassar F. Nassar Mohamed Alamen Sharif Hala Jarallah El-Khozondar	Bani Waleed University, Bani Waleed, Libya College of Civil Aviation, Misrata, Libya Wadi Alshatti University, Brack-Libya Sebha University, Libya Islamic University of Gaza, Gaza, Palestine	SMART HOMES PROGRAMMING FOR IMPROVING SUSTAINABILITY IN RESIDENTIAL AREAS
Mostefa KOULALI Abdelkader BOUAZZA	University of Tiaret, Algeria	EFFICIENT AC LOAD MANAGEMENT THROUGH MULTI-SOURCE ENERGY INTEGRATION: PV, FUEL CELL, AND BATTERY IN MULTI-LEVEL INVERTERS
Sami Melik Sara Khelil	Mohamed Khider Biskra University, Algeria	ETHICAL DIMENSIONS OF ENERGY-EFFICIENT ARCHITECTURE IN ECOSYSTEM CONSERVATION



**27.09.2023 / Hall-3, Session-1 / TSI Time - 13<sup>00</sup>:15<sup>00</sup>**



**Zoom ID: 871 0713 9228 / Passcode: 272727**



**Moderator: Assoc. Prof. Dr. Mustafa ÖZCAN**

<b>Authors</b>	<b>Affiliation</b>	<b>Presentation title</b>
<b>Shalomin Gardner</b>	St. John's College, India Dr. Bhimrao Ambedkar University, India	AN INVESTIGATION INTO THE PHYSICAL PARAMETERS AFFECTING THE EXERGY EFFICIENCY OF PVT AIR COLLECTORS
<b>Yasmine Mekkas Assoc. Prof. Dr. Hani Benguesmia Aissa Chouder</b>	University of M'sila, Algeria	REALIZATION OF A DEVICE FOR MEASURING SOLAR IRRADIATION USING ARDUINO UNO
<b>Assoc. Prof. Dr. Badis Bakri Hani Benguesmia Zied Dris</b>	University of M'sila, Algeria	APPLICATION OF NEURAL NETWORKS SOLAR RADIATION PREDICTION (REGION OF M'SILA)
<b>Dr. Neslihan AYDIN</b>	Bursa Uludag University, Türkiye	SOLAR ENERGY POTENTIAL OF THE EASTERN ANATOLIA REGION AND THE CASE OF KARS PROVINCE
<b>Enes MAVİ Res. Assist. Halit ARAT Prof. Dr. Oğuz ARSLAN</b>	Dumlupınar University, Türkiye Bilecik Şeyh Edebali University, Türkiye	INVESTIGATION OF SOLAR ENERGY IN SUPPORTING THE HEATING AND ELECTRICITY NEEDS OF A FACULTY BUILDING
<b>Enes MAVİ Res. Assist. Halit ARAT Prof. Dr. Oğuz ARSLAN</b>	Dumlupınar University, Türkiye Bilecik Şeyh Edebali University, Türkiye	STUDY ON THE USAGE OF SOLAR ENERGY IN SUPPORTING THE ELECTRICITY NEEDS OF THE ENGINEERING FACULTY BUILDING OF KUTAHYA DÜMLÜPİNAR UNIVERSITY
<b>Abdullah ZORLU Assoc. Prof. Dr. Mustafa ÖZCAN</b>	Kocaeli University, Türkiye	EVALUATION OF UNLICENSED ROOFTOP AND FACADE SOLAR POWER PLANT PROJECT APPLICATIONS IN TÜRKİYE
<b>Mevlûde Merve KARA Assoc. Prof. Dr. Bülent YANIKTEPE Assist. Prof. Dr. Osman KARA</b>	Osmaniye Korkut Ata University, Türkiye	DETERMINATION OF DESIGN PARAMETERS FOR A THROUGH-TYPE PARABOLIC SOLAR COLLECTOR

**27.09.2023 / Hall-4, Session-1 / TSI Time - 13<sup>00</sup>:15<sup>00</sup>**



**Zoom ID: 871 0713 9228 / Passcode: 272727**



**Moderator: Assoc. Prof. Dr. Harminder Singh**

<b>Authors</b>	<b>Affiliation</b>	<b>Presentation title</b>
<b>Dr. Minh Le Thi</b>	Thu Dau Mot University, Vietnam	VIETNAM'S POLICY ON CO <sub>2</sub> EMISSIONS IN THE CONTEXT OF ACCESSING INTERNATIONAL AGREEMENTS
<b>Assist. Prof. Dr. Rozina Khattak</b>	Shaheed Benazir Bhutto Women University, Pakistan	VICTORIA GREEN B PHOTOCATALYTIC DEGRADATION IN WATER
<b>Assist. Prof. Dr. Rozina Khattak</b>	Shaheed Benazir Bhutto Women University, Pakistan	ENVIRONMENTAL REMEDIATION BY USING WASTE BASED BIOSORPTION OF BASIC GREEN 4 FROM WATER
<b>Toumi Meriem Abdelli Islem Safia Abdelmalek Fatiha Addou Ahmed</b>	Abdelhamid Ibn-Badis University, Algeria	ESTIMATING THE METHANE EMISSION AND ENERGY POTENTIAL FROM BLIDA DUMPSITE BY LANDGEM MODEL
<b>Dr. Ishaq Ali Shah Haroon Khan Zahir Muhammad Rehman Ulla</b>	University of Peshawar, Pakistan The University of Agriculture, Pakistan	CLIMATE CHANGE IMPACT IN PAKISTAN- A REVIEW
<b>Assist. Prof. Dr. Saltuk Buğra SELÇUKLU Atabek MOVLYANOV</b>	Erciyes University, Türkiye	ENERGY PLANNING AND OPTIMIZATION MODELING FOR CAMPUS BUILDINGS AND TRANSPORTATION
<b>Iffikhar Yasin</b>	The University of Lahore, Pakistan	A COMPARATIVE ANALYSIS OF CARBON EMISSIONS AND ECOLOGICAL FOOTPRINTS: THE MODERATING ROLE OF ICT IN THE NATURAL RESOURCE RENT AND ENVIRONMENTAL DAMAGE NEXUS IN BRICS
<b>Assoc. Prof. Dr. Harminder Singh</b>	Guru Nanak Dev University, India	WASTE-TO-ENERGY PLANTS: SOURCE OF ENERGY UTILIZING WASTE PRODUCTS

**27.09.2023 / Hall-5, Session-1 / TSI Time - 13<sup>00</sup>:15<sup>00</sup>**



**Zoom ID: 871 0713 9228 / Passcode: 272727**



**Moderator: Prof. Dr. Cemil ALKAN**

<b>Authors</b>	<b>Affiliation</b>	<b>Presentation title</b>
<b>Douara Ben ouadeh Kouzou Abdellah Chouiha Youcef Karboua Djaloul Mebkhouta Toufik</b>	Zain Achour University of Djelfa, Algeria Mohamed Khider University of Biskra, Algeria	A ROBUST CONTROL FOR WIND ENERGY CONVERSION SYSTEM BASED ON FIVE PHASES PERMANENT MAGNET SYNCHRONOUS GENERATOR
<b>Chouiha Youcef Beladel Abdelkader Kouzou Abdellah Douara Ben ouadeh Karboua Djaloul Mebkhouta Toufik</b>	Zain Achour University of Djelfa, Algeria Mohamed Khider University of Biskra, Algeria	SOLAR PUMPING SYSTEM BASED ON AN INDUCTION MOTOR
<b>Assist. Prof. Dr. Bahadır Erman YÜCE</b>	Bitlis Eren University, Türkiye	CONVENTIONAL AND ADVANCED EXERGY ANALYSIS OF A RANKINE CYCLE
<b>Dr. Müyesser Selda TÖZÜM Dr. Sena DEMİRBAĞ GENÇ Prof. Dr. Sennur ALAY AKSOY</b>	Uşak University, Türkiye	PRODUCTION OF GELATIN/ARABIC GUM WALLED THERMOCHROMIC AND THERMAL ENERGY STORING MICROCAPSULES CONTAINING FLUORAN DYE
<b>Prof. Dr. Sennur ALAY AKSOY Simge ÖZKAYALAR Prof. Dr. Cemil ALKAN</b>	Süleyman Demirel University, Türkiye Dokuz Eylül University, Türkiye Tokat Gaziosmanpaşa University, Türkiye	NANOENCAPSULATION OF FLUORAN DYE AND N-DODECANOL BASED SYSTEMS WITH PMMA-CO-GMA WALL FOR THERMOCHROMIC AND THERMAL ENERGY STORAGE FUNCTIONS
<b>Prof. Dr. Demet YILMAZ Prof. Dr. Sennur ALAY AKSOY</b>	Süleyman Demirel University, Türkiye	THE MANUFACTURING OF MICROENCAPSULATED PHASE CHANGE MATERIAL INCORPORATED VISCOSE YARNS SUITABLE FOR THERMOREGULATION APPLICATIONS
<b>Süleyman ŞİŞMAN Mehmet İPEKOĞLU Cem UÇARKUŞ</b>	Turkish and German University, Türkiye	EXPLORING HEAT TRANSFER IN GRAPHENE OXIDE NANOFUIDS AT DIFFERENT FLOW SPEEDS
<b>Nazan Gökşen Tosun Erdoğan Halis Alakara Cemil Alkan</b>	Tokat Gaziosmanpaşa University, Türkiye	SYNTHESIS AND CHARACTERIZATION OF A P(VCL-co-MA) COPOLYMER AS THERMOTROPIC POLYMER
<b>Nazan Gökşen Tosun Cemil Alkan</b>	Tokat Gaziosmanpaşa University, Türkiye	1,2-PHENYLENE DISTEARYLAMIDE AS A NOVEL PHASE CHANGE MATERIAL FOR THERMAL ENERGY STORAGE

27.09.2023 / Hall-1, Session-2 / TSI Time - 15<sup>30</sup>:17<sup>30</sup>



Zoom ID: 871 0713 9228 / Passcode: 272727



Moderator: Assist. Prof. Dr. Pınar Buket KILINÇ PALA

Authors	Affiliation	Presentation title
Prof. Dr. Mehmet TUNÇER Res. Assist. Hasret KAYA	Karadeniz Technical University, Türkiye	EFFECT OF FINANCIAL INCENTIVE POLICIES ON RENEWABLE ELECTRIC ENERGY PRODUCTION: AN EVALUATION FROM TURKIYE'S PERSPECTIVE
Prof. Dr. Meftin CANCI Gizem ALKAN KABAKCI	Yalova University, Türkiye Stellantis N.V., Türkiye	CONSUMER PREFERENCES ON ELECTRIC VEHICLES: A COMPARISON STUDY APPLYING TOPSIS AND VIKOR METHODS AS MULTI CRITERIA DECISION ANALYSES
Lect. Funda DURGUN Res. Assist. Dr. Şener İLTER	Dicle University, Türkiye	THE IMPACT OF RENEWABLE ENERGY AND NATURAL GAS CONSUMPTION ON HUMAN DEVELOPMENT: RALS FADL APPROACH
Asst. Prof. Dr. Umut ERCAN Asst. Prof. Dr. Muzaffer ALIM	Batman University, Türkiye	FORECASTING SOLAR PANEL ELECTRICITY PRODUCTION AND ANALYZING ECONOMIC VIABILITY CONSIDERING CARBON PRICES
Assist. Prof. Dr. Pınar Buket KILINÇ PALA	Dumlupınar University, Türkiye	DIGITAL DIPLOMACY AND ITS IMPACT ON INTERNATIONAL RELATIONS: THE POWER OF DIGITAL TRANSFORMATION TO DIRECT CLIMATE AND ENVIRONMENTAL POLICIES
Başak İrem Öztürk Assist. Prof. Dr. Umut Uğurlu	Bahcesehir University, Türkiye	EFFECT OF COVID-19 AND GLOBAL ENERGY CRISIS ON ELECTRICITY PRICES
Assist. Prof. Dr. Serdar ERDOĞAN	Trakya University, Türkiye	INVESTIGATION OF GREENHOUSE GAS EMISSION WITH CAUSALITY ANALYSIS IN TERMS OF DEVELOPMENT ECONOMICS: THE CASE OF TURKEY

**27.09.2023 / Hall-2, Session-2 / TSI Time - 15<sup>30</sup>:17<sup>30</sup>**



**Zoom ID: 871 0713 9228 / Passcode: 272727**



**Moderator: Isaac Jato**

<b>Authors</b>	<b>Affiliation</b>	<b>Presentation title</b>
<b>Aliyu Ishaq Mohd Ismid Mohd Said Shamila. Binti Azman Shamsudeen Mohammed Jumande Al-Amin Danladi Bello</b>	Universiti Teknologi Malaysia, Malaysia Ahmadu Bello University, Nigeria	IMPACT OF DYNAMIC COD LOADING PROFILES ON BIOENERGY GENERATION AND SIMULTANEOUS WASTEWATER TREATMENT IN MICROBIAL FUEL CELLS
<b>M. Mamuda I. A. Khalil A. M. Sokoto</b>	Usmanu Danfodiyo University, Nigeria Sultan Muhammadu Maccido Institute for Qur'an and General Studies, Nigeria	EVALUTAION OF GARLIC EXTRACT AS A NATURAL ANTIOXIDANT FOR J. CURCAS BIODIESEL STABILITY
<b>Boughedir Nadia Bailliche Zohra</b>	Université de Ain. Algeria	CATALYTIC ESTERIFICATION OF BIODIESEL USING MESOPOROUS MATERIAL
<b>Isaac Jato Kabir Garb Maryam Ibrahim Ahmed Mohammed Inuwa Faizah Idris Sallau Sagir Umar Habibu Abubakar Waniyo</b>	Federal Polytechnic N'yak Shendam, Nigeria Abubakar Tafawa Balewa University, Nigeria	HYDROTHERMAL GASIFICATION OF SELECTED FOODS FOR SUSTAINABLE ENERGY GENERATION USING ASPEN PLUS
<b>Isaac Jato Ahmed Mohammed Inuwa Habibu Abubakar Waniyo Faizah Idris Sallau</b>	Federal Polytechnic N'yak Shendam, Nigeria Abubakar Tafawa Balewa University, Nigeria	A REVIEW ON BIO-OIL PRODUCTION AND UPGRADING USING ZEOLITE CATALYST
<b>Isaac Jato Ahmed Mohammed Inuwa Habibu Abubakar Waniyo</b>	Federal Polytechnic N'yak Shendam, Nigeria Abubakar Tafawa Balewa University, Nigeria	OPTIMIZATION OF LINEAR ALKYL BENZENE YIELD USING DESIGN EXPERT
<b>Prof. Valentina Marinescu Dr. Ramona Marinache</b>	University of Bucharest, Romania	THE FUTURE OF ENERGY SUSTAINABILITY – A THOUGHT EXERCICE

27.09.2023 / Hall-3, Session-2 / TSI Time - 15<sup>30</sup>:17<sup>30</sup>



Zoom ID: 871 0713 9228 / Passcode: 272727



Moderator: Assoc. Prof. Dr. Seyda EMEKÇİ

Authors	Affiliation	Presentation title
Osman Dogukan Urkan Assoc. Prof. Dr. Meric Cetin Mahmut Hekim	Pamukkale University, Türkiye Karamanoglu Mehmetbey University, Türkiye	HYPERPARAMETER OPTIMIZATION: A CASE STUDY FOR GEOTHERMAL-THERMOELECTRIC EXPERIMENTAL SETUP
Prof. Dr. Mohammad Asaduzzaman Chowdhury MD. Helal Hossain	Dhaka University of Engineering & Technology, Bangladesh	FABRICATION OF SILICON-BASED COMPOSITE COATING FOR ENERGY STORAGE AND SEMICONDUCTOR APPLICATIONS
Hasan YEŞİLYURT Assoc. Prof. Dr. Ahmet Şakir DOKUZ	Aksaray University, Türkiye Niğde Ömer Halisdemir University, Türkiye	TOTAL BUILDING ENERGY CONSUMPTION FORECASTING BASED ON AIR CONDITIONING CONSUMPTION USING MACHINE LEARNING ALGORITHMS
Lect. Emre ÖZER Assoc. Prof. Dr. Furkan DİNÇER	Gaziantep Islam Science and Technology University, Türkiye Kahramanmaraş Sütçü Imam University, Türkiye	DESIGN AND SIMULATION OF PHOTOVOLTAIC ENERGY STORAGE SYSTEM FOR TEMPORARY SHELTERS AFTER DISASTERS
Lect. Emre ÖZER Assoc. Prof. Dr. Furkan DİNÇER	Gaziantep Islam Science and Technology University, Türkiye Kahramanmaraş Sütçü Imam University, Türkiye	DESIGN AND SIMULATION OF PHOTOVOLTAIC PANEL INTEGRATED WATER PUMPING SYSTEM: A CASE STUDY IN CEYHAN, ADANA CORN FIELD
Res. Assist. Oğuzhan KATAR Assoc. Prof. Özal YILDIRIM	Firat University, Türkiye	A POWER QUALITY CLASSIFICATION METHOD BASED ON XGBOOST
Özgür BEDER Prof. Dr. Hakan ÖZCAN	Ondokuzmayıs University, Türkiye	THE INVESTIGATION OF MECHANICAL AND CORROSIVE PROPERTIES OF PYROLYSIS OIL ON AUTOMOTIVE MATERIALS
Assoc. Prof. Dr. Seyda EMEKÇİ	Ankara Yıldırım Beyazıt University, Türkiye	THE INTEGRAL ROLE OF ARCHITECTURAL DESIGNS IN ENERGY-EFFICIENT SMART CITIES

**27.09.2023 / Hall-4, Session-2 / TSI Time - 15<sup>30</sup>:17<sup>30</sup>**



**Zoom ID: 871 0713 9228 / Passcode: 272727**



**Moderator: Prof. Dr. Felix A. HIMMELSTOSS**

<b>Authors</b>	<b>Affiliation</b>	<b>Presentation title</b>
<b>Prof. Dr. Felix A. HIMMELSTOSS</b>	University of Applied Sciences Technikum Wien, Austria	MODIFIED TRI-STATE STEP-UP CONVERTER WITH COUPLED COILS
<b>P. Sivaraj Dr. C. M. Raguraman</b>	Annamalai University, India	IMPLEMENTATION AND TESTING OF A SOLAR DECLINATOR WITH WATER PREHEATING
<b>Youness Hakam Ahmed Gaga Benachir El Hadadi</b>	Sultan Moulay Slimane University, Morocco	ELECTRIC VEHICLE CHARGER BASED ON PID CONTROLLER
<b>Hajar ahessab Ahmed Gaga Benachir El Hadadi</b>	Sultan Moulay Slimane University, Morocco	SOLAR CHARGING SYSTEM BASED ON ARTIFICIAL NEURAL NETWORK
<b>R. Tamizh Selvan Dr. V. Thiyagarajan</b>	Sri Sivasubramaniya Nadar College of Engineering, India	ANALYSIS OF REDUCED SWITCH MULTILEVEL INVERTERS FOR ELECTRIC VEHICLE APPLICATIONS
<b>Res. Assist. Oğuzhan KATAR Assoc. Prof. Dr. Özal YILDIRIM</b>	Firat University, Türkiye	AN ENSEMBLE HARD VOTING MODEL FOR ELECTRICAL FAULT DETECTION
<b>Ozan TURANLI Res. Assist. Yurdagül BENTEŞEN YAKUT</b>	GDZ Electrical Energy inc., Türkiye Dicle University, Türkiye	ELECTRICAL FAILURE DETECTION WITH MACHINE LEARNING IN POWER SYSTEMS
<b>Yacine Djeghader Nora Daou Omar Feddaoui</b>	University of Mohamed-Cherif Messaadia, Algeria Hassan First University, Morocco	HARMONICS STUDY IN ELECTRICAL GRID CONNECTED RENEWABLE ENERGY SYSTEMS
<b>Michael Okon Bassey Aniekan Essienubong Ikpe Victor Etok Udo</b>	Akwa Ibom State Polytechnic, Nigeria	ANALYZING THE STABILITY OF THE CLOSED-LOOP SYSTEM IN AUTOMOBILE ADAPTIVE CRUISE CONTROL SYSTEMS

**27.09.2023 / Hall-5, Session-2 / TSI Time - 15<sup>30</sup>:17<sup>30</sup>**



**Zoom ID: 871 0713 9228 / Passcode: 272727**



**Moderator: Dr. Dhananjay R. Mishra**

<b>Authors</b>	<b>Affiliation</b>	<b>Presentation title</b>
<b>Res. Assist. İsmail DEMİRKIRAN Prof. Dr. Erdal ÇETKİN</b>	İzmir Institute of Technology (IZTECH), Türkiye	NUMERICAL INVESTIGATION OF VARIOUS MOTHER-FIN LENGTHS FOR T-SHAPED FINN ON THE MELTING PROCESS
<b>Amiya Kumar Sahoo Dr. Dhananjay R. Mishra</b>	Jaypee University of Engineering and Technology, India	PARAMETRIC OPTIMIZATION OF ND: YAG LASER DRILLING OPERATION ON BASALT-PFTE COATED GLASS WOVEN FIBRE HYBRID COMPOSITE FOR HOLE TAPER USING TEACHING LEARNING BASED OPTIMIZATION ALGORITHM
<b>Purushottam Kumar BP Singh</b>	Dr. Bhimrao Ambedkar University, India	STUDY OF THERMAL BEHAVIOR OF LITHIUM-ION BATTERIES USING SOFTWARE
<b>Gusthyta Putri Nabila Hendri Hermawan Adinugraha</b>	UIN K.H. Abdurrahman Wahid Pekalongan, Indonesia	THE IMPACT OF INCREASING FUEL PRICES ON FAMILY BUDGET IN INDONESIA
<b>Usman Aliyu Taliyawa Hamma Ibrahim Siddi Umar Zahradeen Saidu Abdullahi Kwace</b>	Modibbo Adama University, Nigeria	ENVIRONMENTAL IMPACT ANALYSIS OF LITHIUM EXTRACTION PRESENTERS
<b>Mohammed Alaa Alwafaie Bela Kovacs</b>	The University of Miskolc, Hungary	THE REVIEW OF INFRASTRUCTURE REQUIREMENTS FOR ELECTRIC AUTOMOTIVE
<b>Zeynep PEKDEMİR Ahmet Gürkan YÜKSEK Derya Betül ÜNSAL</b>	Sivas Cumhuriyet University, Türkiye	IMPROVEMENTS OF NEXT GENERATION IoT APPLICATIONS SECURITY CHALLENGES
<b>Derya Betül ÜNSAL</b>	Sivas Cumhuriyet University, Türkiye	PHOTOVOLTAICS ENERGY CONTRIBUTION AND THEIR IMPACT ON CARBON EMISSIONS REDUCTION IN TÜRKİYE



# CONTENT

<b>SYMPOSIUM ID</b>	<b>I</b>
<b>SCIENTIFIC &amp; REVIEW COMMITTEE</b>	<b>II</b>
<b>PHOTO GALLERY</b>	<b>III</b>
<b>PROGRAM</b>	<b>IV</b>
<b>CONTENT</b>	<b>V</b>

<b>Author</b>	<b>Title</b>	<b>No</b>
<b>Arman Jalali Fereshteh Garebaghi Maleki</b>	BIOHYDROGEN: A SUSTAINABLE AND PROMISING ENERGY SOURCE (PRODUCTION, STORAGE AND TRANSPORTATION)	<b>1</b>
<b>Halil Cecen</b>	REVIEW OF THE CURRENT DEVELOPMENTS REGARDING THE INVESTMENTS IN OFFSHORE WIND ENERGY IN TURKIYE WITHIN THE FRAMEWORK OF THE RENEWABLE ENERGY POLICY OF THE EUROPEAN UNIO	<b>2</b>
<b>Halil Cecen</b>	“COVENANT OF COMPANIES FOR CLIMATE AND ENERGY” AS A NEW PILOT INITIATIVE IN THE EUROPEAN UNION REGARDING THE CONTRIBUTIONS OF COMPANIES TO COMBATING CLIMATE CHANGE	<b>3</b>
<b>Oussama MOUSS Lallouani HELLALI Riyadh ROUABH Aboubaker Essadiq MAZOUZ Ali BOUZIDI Ali AKKA</b>	ROBUST NONLINEAR CONTROL VIA FEEDBACK LINEARIZATION AND LYAPUNOV THEORY FOR BRUSHLESS DOUBLY FED INDUCTION GENERATOR BASED ON WIND ENERGY CONVERSION SYSTEM	<b>4</b>
<b>Halali Youcef Ghaitaoui Touhami Ouledali Omar Ghaitaoui Ahmed Essama</b>	SLIDING MODE BASED P&O MPPT FOR SOLAR PV SYSTEM	<b>5</b>
<b>Arman Jalali</b>	THE IMPORTANCE OF RENEWABLE ENERGY STORAGE FOR A SUSTAINABLE FUTURE	<b>6</b>
<b>Hüseyin Utku HELVACI Mehmet Süha İŞİ</b>	ONE DIMENSIONAL AND THREE DIMENSIONAL THERMAL ANALYSIS OF AN AIR-COOLED PEM FUEL CELL	<b>7</b>
<b>Tuba ARTAN ONAT İlknur ERKİLİNÇ Furkan BAŞ</b>	A NEW APPROACH TO WASTEWATER TREATMENT: MICROBIAL FUEL CELLS	<b>14</b>
<b>Öznur Begüm GÖKÇEK Hamdi MURATÇOBANOĞLU Sevgi DEMİREL</b>	SUSTAINABLE ALGAL BIOECONOMY FOR BIOFUEL	<b>15</b>
<b>Cəfərov Fazil Tatarxan oğlu Məmmədov Sabir Rüstəm oğlu Abdussalam Ali Ahmed Abdulgader Alsharif Mohammed Khaleel Yassar F. Nassar Mohamed Alamen Sharif Hala Jarallah El-Khozondar</b>	ALTERNATIVE ENERGY AND ITS USE IN AZERBAIJAN	<b>16</b>
<b>Mostefa KOULALI Abdelkader BOUAZZA</b>	SMART HOMES PROGRAMMING FOR IMPROVING SUSTAINABILITY IN RESIDENTIAL AREAS	<b>20</b>
<b>Mostefa KOULALI Abdelkader BOUAZZA</b>	EFFICIENT AC LOAD MANAGEMENT THROUGH MULTI-SOURCE ENERGY INTEGRATION: PV, FUEL CELL, AND BATTERY IN MULTI-LEVEL INVERTERS	<b>28</b>
<b>Sami Melik Sara Khelil</b>	ETHICAL DIMENSIONS OF ENERGY-EFFICIENT ARCHITECTURE IN ECOSYSTEM CONSERVATION	<b>29</b>

<b>Shalomin Gardner</b>	AN INVESTIGATION INTO THE PHYSICAL PARAMETERS AFFECTING THE EXERGY EFFICIENCY OF PVT AIR COLLECTORS	47
<b>Yasmine Mekkas Hani Benguesmia Aissa Chouder</b>	REALIZATION OF A DEVICE FOR MEASURING SOLAR IRRADIATION USING ARDUINO UNO	48
<b>Badis Bakri Hani Benguesmia Zied Dris</b>	APPLICATION OF NEURAL NETWORKS SOLAR RADIATION PREDICTION (REGION OF M'SILA)	49
<b>Neslihan AYDIN</b>	SOLAR ENERGY POTENTIAL OF THE EASTERN ANATOLIA REGION AND THE CASE OF KARS PROVINCE	50
<b>Enes MAVİ Halit ARAT Oğuz ARSLAN</b>	INVESTIGATION OF SOLAR ENERGY IN SUPPORTING THE HEATING AND ELECTRICITY NEEDS OF A FACULTY BUILDING	59
<b>Enes MAVİ Halit ARAT Oğuz ARSLAN</b>	STUDY ON THE USAGE OF SOLAR ENERGY IN SUPPORTING THE ELECTRICITY NEEDS OF THE ENGINEERING FACULTY BUILDING OF KUTAHYA DÜMLÜPINAR UNIVERSITY	60
<b>Abdullah ZORLU Mustafa ÖZCAN</b>	EVALUATION OF UNLICENSED ROOFTOP AND FACADE SOLAR POWER PLANT PROJECT APPLICATIONS IN TÜRKİYE	61
<b>Mevlüde Merve KARA Bülent YANIKTEPE Osman KARA</b>	DETERMINATION OF DESIGN PARAMETERS FOR A THROUGH-TYPE PARABOLIC SOLAR COLLECTOR	85
<b>Minh Le Thi</b>	VIETNAM'S POLICY ON CO <sub>2</sub> EMISSIONS IN THE CONTEXT OF ACCESSING INTERNATIONAL AGREEMENTS	89
<b>Rozina Khattak</b>	VICTORIA GREEN B PHOTOCATALYTIC DEGRADATION IN WATER	100
<b>Rozina Khattak</b>	ENVIRONMENTAL REMEDIATION BY USING WASTE BASED BIOSORPTION OF BASIC GREEN 4 FROM WATER	101
<b>Toumi Meriem Abdelli Islem Safia Abdelmalek Fatiha Addou Ahmed</b>	ESTIMATING THE METHANE EMISSION AND ENERGY POTENTIAL FROM BLIDA DUMPSITE BY LANDGEM MODEL	102
<b>Dr. Ishaq Ali Shah Haroon Khan Zahir Muhammad Rehman Ulla</b>	CLIMATE CHANGE IMPACT IN PAKISTAN- A REVIEW	103
<b>Iffikhar Yasin</b>	A COMPARATIVE ANALYSIS OF CARBON EMISSIONS AND ECOLOGICAL FOOTPRINTS: THE MODERATING ROLE OF ICT IN THE NATURAL RESOURCE RENT AND ENVIRONMENTAL DAMAGE NEXUS IN BRICS	104
<b>Harminder Singh</b>	WASTE-TO-ENERGY PLANTS: SOURCE OF ENERGY UTILIZING WASTE PRODUCTS	105
<b>Douara Ben ouadeh Kouzou Abdellah Chouiha Youcef Karboua Djaloul Mebkhouta Toufik</b>	A ROBUST CONTROL FOR WIND ENERGY CONVERSION SYSTEM BASED ON FIVE PHASES PERMANENT MAGNET SYNCHRONOUS GENERATOR	108
<b>Chouiha Youcef Beladel Abdelkader Kouzou Abdellah Douara Ben ouadeh Karboua Djaloul Mebkhouta Toufik</b>	SOLAR PUMPING SYSTEM BASED ON AN INDUCTION MOTOR	109
<b>Bahadır Erman YÜCE</b>	CONVENTIONAL AND ADVANCED EXERGY ANALYSIS OF A RANKINE CYCLE	110

<b>Müeyesser Selda TÖZÜM Sena DEMİRBAĞ GENÇ Sennur ALAY AKSOY</b>	PRODUCTION OF GELATIN/ARABIC GUM WALLED THERMOCHROMIC AND THERMAL ENERGY STORING MICROCAPSULES CONTAINING FLUORAN DYE	111
<b>Sennur ALAY AKSOY Simge ÖZKAYALAR Cemil ALKAN</b>	NANOENCAPSULATION OF FLUORAN DYE AND N-DODECANOL BASED SYSTEMS WITH PMMA-CO-GMA WALL FOR THERMOCHROMIC AND THERMAL ENERGY STORAGE FUNCTIONS	119
<b>Demet YILMAZ Sennur ALAY AKSOY</b>	THE MANUFACTURING OF MICROENCAPSULATED PHASE CHANGE MATERIAL INCORPORATED VISCOSE YARNS SUITABLE FOR THERMOREGULATION APPLICATIONS	129
<b>Süleyman ŞİŞMAN Mehmet İPEKOĞLU Cem UÇARKUŞ</b>	EXPLORING HEAT TRANSFER IN GRAPHENE OXIDE NANOFLUIDS AT DIFFERENT FLOW SPEEDS	138
<b>Nazan Gökşen Tosun Erdoğan Halis Alakara Cemil Alkan</b>	SYNTHESIS AND CHARACTERIZATION OF A P(VCL-co-MA) COPOLYMER AS THERMOTROPIC POLYMER	144
<b>Nazan Gökşen Tosun Cemil Alkan</b>	1,2-PHENYLENE DISTEARYLAMIDE AS A NOVEL PHASE CHANGE MATERIAL FOR THERMAL ENERGY STORAGE	152
<b>Mehmet TUNÇER Hasret KAYA</b>	EFFECT OF FINANCIAL INCENTIVE POLICIES ON RENEWABLE ELECTRIC ENERGY PRODUCTION: AN EVALUATION FROM TURKIYE'S PERSPECTIVE	161
<b>Metin CANCI Gizem ALKAN KABAKCI</b>	CONSUMER PREFERENCES ON ELECTRIC VEHICLES: A COMPARISON STUDY APPLYING TOPSIS AND VIKOR METHODS AS MULTI CRITERIA DECISION ANALYSES	172
<b>Funda DURGUN Şener İLTER</b>	THE IMPACT OF RENEWABLE ENERGY AND NATURAL GAS CONSUMPTION ON HUMAN DEVELOPMENT: RALS FADL APPROACH	173
<b>Umut ERCAN Muzaffer ALIM</b>	FORECASTING SOLAR PANEL ELECTRICITY PRODUCTION AND ANALYZING ECONOMIC VIABILITY CONSIDERING CARBON PRICES	175
<b>Pınar Buket KILINÇ PALA</b>	DIGITAL DIPLOMACY AND ITS IMPACT ON INTERNATIONAL RELATIONS: THE POWER OF DIGITAL TRANSFORMATION TO DIRECT CLIMATE AND ENVIRONMENTAL POLICIES	182
<b>Başak İrem Öztürk Umut Uğurlu</b>	EFFECT OF COVID-19 AND GLOBAL ENERGY CRISIS ON ELECTRICITY PRICES	183
<b>Serdar ERDOĞAN</b>	INVESTIGATION OF GREENHOUSE GAS EMISSION WITH CAUSALITY ANALYSIS IN TERMS OF DEVELOPMENT ECONOMICS: THE CASE OF TURKEY	184
<b>Aliyu Ishaq Mohd Ismid Mohd Said Shamila. Binti Azman Shamsudeen Mohammed Jumande Al-Amin Danladi Bello</b>	IMPACT OF DYNAMIC COD LOADING PROFILES ON BIOENERGY GENERATION AND SIMULTANEOUS WASTEWATER TREATMENT IN MICROBIAL FUEL CELLS	191
<b>M. Mamuda I. A. Khalil A. M. Sokoto</b>	EVALUTAION OF GARLIC EXTRACT AS A NATURAL ANTIOXIDANT FOR J. CURCAS BIODIESEL STABILITY	192
<b>Boughedir Nadia Bailliche Zohra Isaac Jato Kabir Garb</b>	CATALYTIC ESTERIFICATION OF BIODIESEL USING MESOPOROUS MATERIAL	193
<b>Maryam Ibrahim Ahmed Mohammed Inuwa Faizah Idris Sallau Sagir Umar Habibu Abubakar Waniyo</b>	HYDROTHERMAL GASIFICATION OF SELECTED FOODS FOR SUSTAINABLE ENERGY GENERATION USING ASPEN PLUS	194

<b>Isaac Jato Ahmed Mohammed Inuwa Habibu Abubakar Waniyo Faizah Idris Sallau</b>	A REVIEW ON BIO-OIL PRODUCTION AND UPGRADING USING ZEOLITE CATALYST	195
<b>Isaac Jato Ahmed Mohammed Inuwa Habibu Abubakar Waniyo</b>	OPTIMIZATION OF LINEAR ALKYL BENZENE YIELD USING DESIGN EXPERT	196
<b>Valentina Marinescu Dr. Ramona Marinache</b>	THE FUTURE OF ENERGY SUSTAINABILITY – A THOUGHT EXERCICE	197
<b>Osman Dogukan Urkan Dr. Meric Cetin Mahmut Hekim</b>	HYPERPARAMETER OPTIMIZATION: A CASE STUDY FOR GEOTHERMAL-THERMOELECTRIC EXPERIMENTAL SETUP	198
<b>Mohammad Asaduzzaman Chowdhury Helal Hossain</b>	FABRICATION OF SILICON-BASED COMPOSITE COATING FOR ENERGY STORAGE AND SEMICONDUCTOR APPLICATIONS	206
<b>Hasan YEŞİLYURT Ahmet Şakir DOKUZ</b>	TOTAL BUILDING ENERGY CONSUMPTION FORECASTING BASED ON AIR CONDITIONING CONSUMPTION USING MACHINE LEARNING ALGORITHMS	207
<b>Lect. Emre ÖZER Furkan DİNÇER</b>	DESIGN AND SIMULATION OF PHOTOVOLTAIC ENERGY STORAGE SYSTEM FOR TEMPORARY SHELTERS AFTER DISASTERS	216
<b>Lect. Emre ÖZER Furkan DİNÇER</b>	DESIGN AND SIMULATION OF PHOTOVOLTAIC PANEL INTEGRATED WATER PUMPING SYSTEM: A CASE STUDY IN CEYHAN, ADANA CORN FIELD	223
<b>Oğuzhan KATAR Özal YILDIRIM</b>	A POWER QUALITY CLASSIFICATION METHOD BASED ON XGBOOST	231
<b>Özgür BEDER Hakan ÖZCAN</b>	THE INVESTIGATION OF MECHANICAL AND CORROSIVE PROPERTIES OF PYROLYSIS OIL ON AUTOMOTIVE MATERIALS	240
<b>Seyda EMEKÇİ</b>	THE INTEGRAL ROLE OF ARCHITECTURAL DESIGNS IN ENERGY-EFFICIENT SMART CITIES	253
<b>Felix A. HIMMELSTOSS</b>	MODIFIED TRI-STATE STEP-UP CONVERTER WITH COUPLED COILS	261
<b>P. Sivaraj C. M. Raguraman</b>	IMPLEMENTATION AND TESTING OF A SOLAR DECLINATOR WITH WATER PREHEATING	278
<b>Youness Hakam Ahmed Gaga Benachir El Hadadi</b>	ELECTRIC VEHICLE CHARGER BASED ON PID CONTROLLER	279
<b>Hajar ahessab Ahmed Gaga Benachir El Hadadi</b>	SOLAR CHARGING SYSTEM BASED ON ARTIFICIAL NEURAL NETWORK	280
<b>R. Tamizh Selvan Dr. V. Thiyagarajan</b>	ANALYSIS OF REDUCED SWITCH MULTILEVEL INVERTERS FOR ELECTRIC VEHICLE APPLICATIONS	281
<b>Oğuzhan KATAR Özal YILDIRIM</b>	AN ENSEMBLE HARD VOTING MODEL FOR ELECTRICAL FAULT DETECTION	282
<b>Ozan TURANLI Yurdagül BENTEŞEN YAKUT</b>	ELECTRICAL FAILURE DETECTION WITH MACHINE LEARNING IN POWER SYSTEMS	288
<b>Yacine Djeghader Nora Daou Omar Feddaoui</b>	HARMONICS STUDY IN ELECTRICAL GRID CONNECTED RENEWABLE ENERGY SYSTEMS	296
<b>Michael Okon Bassey Aniekan Essienubong Ikpe Victor Etok Udo</b>	ANALYZING THE STABILITY OF THE CLOSED-LOOP SYSTEM IN AUTOMOBILE ADAPTIVE CRUISE CONTROL SYSTEMS	297
<b>İsmail DEMİRKIRAN Erdal ÇETKİN</b>	NUMERICAL INVESTIGATION OF VARIOUS MOTHER-FIN LENGTHS FOR T-SHAPED FINS ON THE MELTING PROCESS	308
<b>Amiya Kumar Sahoo Dhananjay R. Mishra</b>	PARAMETRIC OPTIMIZATION OF ND: YAG LASER DRILLING OPERATION ON BASALT-PDTE COATED GLASS WOVEN FIBRE HYBRID COMPOSITE FOR HOLE TAPER USING TEACHING LEARNING BASED OPTIMIZATION ALGORITHM	309

<b>Purushottam Kumar BP Singh</b>	STUDY OF THERMAL BEHAVIOR OF LITHIUM-ION BATTERIES USING SOFTWARE	310
<b>Gusthyta Putri Nabila Hendri Hermawan Adinugraha</b>	THE IMPACT OF INCREASING FUEL PRICES ON FAMILY BUDGET IN INDONESIA	311
<b>Usman Aliyu Taliyawa Hamma Ibrahim Siddi Umar Zahraeen Saidu Abdullahi Kwace</b>	ENVIRONMENTAL IMPACT ANALYSIS OF LITHIUM EXTRACTION PRESENTERS	312
<b>Mohammed Alaa Alwafaie Bela Kovacs</b>	THE REVIEW OF INFRASTRUCTURE REQUIREMENTS FOR ELECTRIC AUTOMOTIVE	313
<b>Saltuk Buğra SELÇUKLU Atabek MOVLYANOV</b>	ENERGY PLANNING AND OPTIMIZATION MODELING FOR CAMPUS BUILDINGS AND TRANSPORTATION	319
<b>Zeynep PEKDEMİR Ahmet Gürkan YÜKSEK Derya Betül ÜNSAL</b>	IMPROVEMENTS OF NEXT GENERATION IoT APPLICATIONS SECURITY CHALLENGES	329
<b>Derya Betül ÜNSAL</b>	PHOTOVOLTAICS ENERGY CONTRIBUTION AND THEIR IMPACT ON CARBON EMISSIONS REDUCTION IN TÜRKİYE	339
<b>Meltem SARIOGLU CEBECİ</b>	EVALUATION OF BIODIESEL OBTAINING FROM WASTE VEGETABLE OILS	346



## BIOHYDROGEN: A SUSTAINABLE AND PROMISING ENERGY SOURCE (PRODUCTION, STORAGE AND TRANSPORTATION)

Arman Jalali<sup>1\*</sup>, Fereshteh Garebaghi Maleki<sup>2</sup>

1. Assistant professor, biosystem Engineering Department University of Tabriz, Tabriz, Iran

2. PhD candidate, Chemical Engineering Department, Sahand University of Technology, Tabriz, Iran

### ABSTRACT

The global demand for clean and sustainable energy sources has led to increased interest in biohydrogen production as an innovative solution. Biohydrogen is an eco-friendly and sustainable fuel that has the potential to revolutionize the energy industry. It can be used as an energy carrier, a feedstock for chemical production, and as a reactant in various industrial applications. Biohydrogen offers numerous advantages, such as being cost-effective, non-polluting, and efficient in energy conversion. This article provides an overview of biohydrogen production methods, constraints, economic analysis, and future prospects. We explore the utilization of biological methods, specifically through the application of microorganisms, to overcome the drawbacks of conventional hydrogen production methods. The article also highlights the importance of optimizing biohydrogen productivity and the challenges faced during its production. With advancements in genetic and metabolic engineering, as well as the integration of various bioreactor designs, biohydrogen production can be significantly enhanced. The production, storage, and transport of biohydrogen present unique challenges that need to be addressed for its widespread adoption. In this comprehensive guide, we will explore the different strategies and technologies for storing and transporting biohydrogen, while highlighting their environmental impact and limitations.



### REVIEW OF THE CURRENT DEVELOPMENTS REGARDING THE INVESTMENTS IN OFFSHORE WIND ENERGY IN TÜRKİYE WITHIN THE FRAMEWORK OF THE RENEWABLE ENERGY POLICY OF THE EUROPEAN UNION

**Dr. Halil Cecen**

Assistant Professor at the Department of the European Union Law under the Private Law Division of the Law Faculty at the Nuh Naci Yazgan University, Kayseri, Türkiye, ORCID ID: 0000-0001-5569-4511

#### ABSTRACT

In this research, current developments in offshore wind energy in Türkiye are discussed within the framework of the renewable energy policy of the European Union and the scope of Turkish renewable energy policy.

As the research on offshore wind energy of the European Union is examined, it is emphasized that the North Sea, the Baltic Sea, the Black Sea and the Mediterranean regions had a significant potential in offshore wind energy. While the total installed renewable energy in Türkiye is 55,943 MW by 2022, there has been no progress for offshore wind energy installations. However, locations in Bandirma, Bozcaada, Gelibolu and Karabiga were declared as candidate Renewable Energy Resource Areas for installing offshore wind powerplants in the announcement dated 4<sup>th</sup> August 2023 by the Ministry of Energy and Natural Resources (Ministry). It should also be noted here that the application price and local content price per kWh as incentives applied for offshore wind energy within the framework of the Turkish Renewable Energy Sources Support Scheme (YEKDEM) are higher than the same incentives applied to most of other renewable energy sources.

Türkiye announced an offshore wind energy auction in 2018, but the auction was postponed. The auction was criticized for some reasons. One of these criticisms was that the simplified administrative process was not implemented. The conditions of the locations, the rate of local content requirements and the absence of offshore supply chain in Turkish market were other criticisms related to the competitiveness of the auction.

For the auctions in the future, which will be held for the offshore wind energy installations upon the announcement of the Ministry, taking these criticisms for the previous auction into consideration will be important in order to add offshore wind energy power into the renewable energy mix in Türkiye.

**Keywords:** offshore wind energy, renewable energy, Türkiye, competitive auction, local content requirement, RES Support Scheme, European Union.



### “COVENANT OF COMPANIES FOR CLIMATE AND ENERGY” AS A NEW PILOT INITIATIVE IN THE EUROPEAN UNION REGARDING THE CONTRIBUTIONS OF COMPANIES TO COMBATING CLIMATE CHANGE

**Dr. Halil Cecen**

Assistant Professor at the Department of the European Union Law under the Private Law Division of the Law Faculty at the Nuh Naci Yazgan University, Kayseri, Türkiye, ORCID ID: 0000-0001-5569-4511

#### ABSTRACT

Covenant of Companies for Climate and Energy (CCCE) is a new pilot initiative led by the European Commission to step up the contribution of European companies to a clean energy transformation and climate action. The required conditions to become signatory in the CCCE are to be based in a Member State of the European Union (EU) and to commit to taking action on decarbonisation under the CCCE.

Four levels were determined in the Covenant of Companies initiative. The first of these levels is the Entry Level. At this initial stage, companies commit to taking reasonable efforts to reduce company's greenhouse gas emissions. Guidance materials and expert courses are also provided to the companies. At the Bronze Level, companies have to carry out reporting by submitting evidence of having implemented a measure to reduce company's greenhouse gas emissions with the help of national and/or European support programme within 12 months after pledging. Companies take several measures to reduce company's greenhouse gas emissions within 24 months after pledging at the Silver Level.

The Gold Level requires companies to take all possible measures that are available to reduce the company's greenhouse gas emissions by more than 40% of combined emissions and to have implemented them within 36 months. Net zero companies, on the other hand, receive a platinum seal or a NET ZERO BUSINESS seal.

The Covenant of Mayors, which supported by the European Commission in Europe, provided the basis for the establishment of the Global Covenant of Mayors. It is foreseen that the Covenant of Companies, which led by the European Commission, shall also provide a basis for the establishment of a Global Covenant of Companies in accelerating the contributions of the private sector to combating climate change following an experience gained in the EU.

**Keywords:** Covenant of Companies for Climate and Energy, Combating Climate Change, Greenhouse Gas Emissions, Net Zero Business, European Union, Covenant of Mayors.



**ROBUST NONLINEAR CONTROL VIA FEEDBACK LINEARIZATION AND LYAPUNOV THEORY FOR BRUSHLESS DOUBLY FED INDUCTION GENERATOR BASED ON WIND ENERGY CONVERSION SYSTEM**

**Oussama MOUSSA<sup>a</sup>, Lallouani HELLALI<sup>b</sup>, Riyadh ROUABHI<sup>c</sup>, Aboubaker Essadiq MAZOUZ<sup>d</sup>, Ali BOUZIDI<sup>e</sup>, Ali AKKA<sup>f</sup>**

<sup>a</sup>Department of Automatics and Electromechanical, Faculty of Science and Technology, Ghardaia, Algeria

<sup>b,c,e</sup>LGE Laboratory, Department of Electrical Engineering, Faculty of Technology, University of M’sila, Algeria.

<sup>d</sup>Department of Electrical Engineering L2GEGI Laboratory, Faculty of applied science, University of Tiaret, Algeria

<sup>f</sup>Department of physics sciences, Higher Normal School of Boussada, Boussada, 28001, Algeria

**ABSTRACT**

In this study, we present a nonlinear control method for a wind energy conversion system (WECS) employing a Brushless Doubly Fed Induction Generator (BDFIG). The aim is to enhance robustness against disturbances and maximize power extraction from a stochastic wind environment. Our proposed algorithm leverages decoupling control, implemented through oriented grid flux vector control. To improve performance, we strive to achieve linear and decoupled control of the generated stator active and reactive powers, ensuring global asymptotic stability. This approach effectively addresses nonlinearity and parameter uncertainties, surpassing conventional control techniques. Our method combines the principles of the Differential Geometric Feedback Linearization Technique (DGT) and Lyapunov theory. The obtained results demonstrate the effectiveness and superior performance of our proposed approach.

**Keywords:** feedback linearization, brushless doubly fed induction generator, vector control, active and reactive power, back-to-back converter.

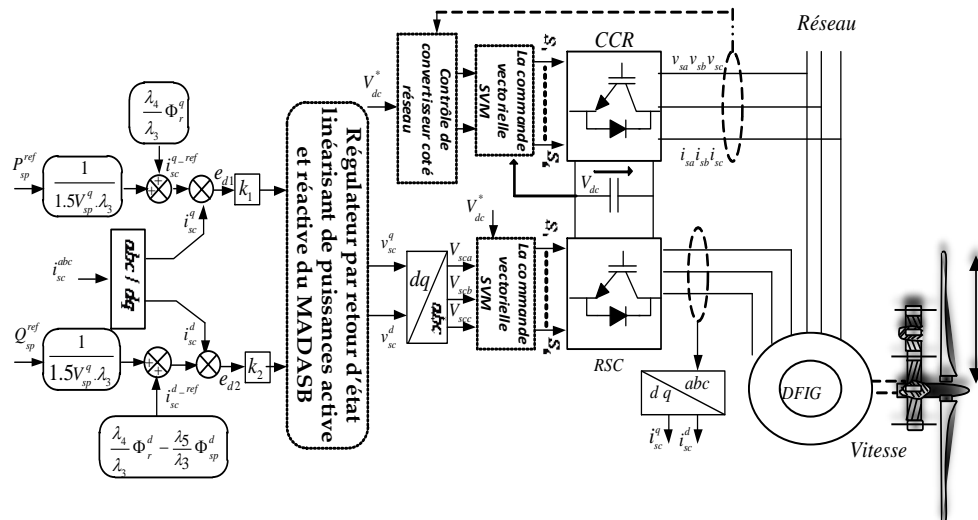

### Graphical abstract



## SLIDING MODE BASED P&O MPPT FOR SOLAR PV SYSTEM

**Halali Youcef, Ghaitaoui Touhami, Ouledali Omar, Ghaitaoui Ahmed Essama**

Laboratoire de Développement Durable et Informatique (LDDI), Faculté des Sciences et de la Technologie, Université d'Adrar, Adrar, Algeria

### ABSTRACT

In this work nonlinear sliding mode control (SMC) techniques formulated for extracting maximum power from a solar photovoltaic (PV) system under variable environmental conditions employing the perturb and observe (P and O) maximum power point tracking (MPPT) technique are discussed. The PV system is connected with load through the boost converter. *the proposed algorithm shows superior robustness against variations in solar radiation and temperature, making it suitable for real-world applications.* The presented control scheme along with the solar PV system is simulated in MATLAB.

**Keywords:** Maximum Power Point Tracking (MPPT), Sliding Mode Control, Pertube observe Optimization (P&O), Solar Photovoltaic (PV) System



### THE IMPORTANCE OF RENEWABLE ENERGY STORAGE FOR A SUSTAINABLE FUTURE

**Arman Jalali**

Assistant professor, Biosystem Engineering Department, university of Tabriz, Tabriz, Iran

#### ABSTRACT

Renewable energy sources, such as solar and wind power, play a crucial role in our transition toward a sustainable and carbon-neutral future. These clean sources of energy are rapidly gaining popularity due to their environmental benefits and potential for reducing our reliance on fossil fuels. However, one significant challenge that arises with renewable energy generation is its intermittent nature, which necessitates the development of effective energy storage solutions. In this article, we will explore the importance of renewable energy storage in achieving a sustainable future and discuss various technologies that can capture and store excess renewable energy. The development and implementation of effective renewable energy storage technologies are essential for achieving a sustainable future. These storage solutions allow us to maximize the utilization of renewable energy sources, reduce reliance on fossil fuels, and mitigate the environmental impact of energy generation. By capturing and storing excess renewable energy, we can ensure a consistent and reliable energy supply, even during periods of low renewable energy generation or high demand. As the demand for renewable energy continues to grow, further advancements in energy storage technologies are crucial. This requires ongoing research, development, and investment to improve the efficiency, scalability, and cost-effectiveness of storage systems. Governments, industry leaders, and researchers must collaborate to drive innovation in renewable energy storage and accelerate the transition to a clean energy future. In conclusion, renewable energy storage plays a vital role in our journey towards a sustainable and carbon-neutral future. By effectively capturing and storing excess renewable energy, we can reduce reliance on fossil fuels, mitigate climate change, and ensure a reliable energy supply. The various energy storage technologies discussed in this article offer promising solutions to overcome the intermittent nature of renewable energy generation. Continued investment and research in renewable energy storage will enable us to achieve our goal of a cleaner and more sustainable energy system.



### ONE DIMENSIONAL AND THREE DIMENSIONAL THERMAL ANALYSIS OF AN AIR-COOLED PEM FUEL CELL

**Hüseyin Utku HELVACI**

Assist. Prof., Dogus University, Faculty of Engineering, Department of Mechanical Engineering, İstanbul-Türkiye  
ORCID: 0000-0003-0091-7807

**Mehmet Süha İŞİ**

Dogus University, Faculty of Engineering, Department of Mechanical Engineering, İstanbul-Türkiye  
ORCID: 0009-0001-4041-9610

#### ABSTRACT

Hydrogen is a clean, renewable energy source and it can be used instead of conventional fossil fuels in order to address environmental problems such as climate change and global warming. Fuel cells that can utilise hydrogen are known as environmentally friendly systems as they generate electricity by releasing water without any carbon emissions. Proton Exchange Membrane (PEM) fuel cells have significant potential thanks to their low operating temperatures, high power densities, and compactness. Although the efficiency of a PEM fuel cell system depends on the type and operating temperature, it is generally higher than other hydrocarbon fuel based systems. The efficiency of a PEM fuel cell is related to the cell temperature and therefore, thermal management is crucial to maintain high system efficiency. Mathematical modelling of the thermal behaviour of PEM fuel cells is essential for the management of the system efficiency. In this study, one and three dimensional models were developed to analyse the thermal behaviour of an air cooled PEM type fuel cell under different operating conditions. MATLAB/Simulink program was used to generate one dimensional thermal model. A single PEM fuel cell was designed using SpaceClaim and ANSYS was utilised to create the three-dimensional thermal model. Furthermore, an experimental test rig was designed and commissioned to compare the model results against with the experimental results. Horizon H-500XP PEM fuel cell was used in the experiments. The results showed that in the ohmic loss region, the deviation for the maximum cell temperature between the model and the experimental results ranged from 1.5% to 4% for the one dimensional model and from 3% to 11% for the three dimensional model.

**Keywords:** PEM fuel cell, mathematical modelling, thermal analysis.

#### Introduction

Fossil fuels supply the majority of the world's energy demand yet they have several drawbacks. The primary disadvantages are their scarcity, the harm their emissions do to the environment, their availability in certain areas, and the ease with which their pricing may be manipulated. (Dresselhaus & Thomas, 2001). Decarbonizing the energy supply with clean and sustainable energy is essential for future energy security and global prosperity (Dawood et al., 2020).

The scarcity of natural hydrocarbon resources has generated great interest in the use of hydrogen as an energy carrier in stationary and mobile applications. This is due to the high energy efficiency of hydrogen, technological flexibility and ecological safety of energy conversion processes using hydrogen. (Yarts & Lototsky, 2004).

Fuel cells can efficiently convert chemical energy directly into electricity. If fuel and oxidant are supplied to fuel cells, the cells continuously produce electrical energy. Most fuel cells have an anode on negative side, a cathode on the positive side, and electrolyte that allows charge to flow between the positive and negative sides of the fuel cell. Fuel cells do not have any combustion mechanism, they produce energy with minimum emissions (Saxena & Verma, 2015). One of the most important considerations in improving fuel cell performance is thermal management. The system must operate within a safe and effective temperature range.

The purpose of thermal management is to maintain the cell temperature within a safe range and to reduce temperature differences between cells (Hmad & Dukhan, 2021).

Several studies, including numerical and experimental modeling that examine heat and mass transfer in PEM fuel cells have been conducted by various researchers. For instance, an experimental study was completed by Jian et al. to investigate thermal response (Jian et al, 2018). Thermal behaviour of PEM fuel cell was investigated with experimental study and the maximum prediction error was calculated between 1.4 K and 2.3 K (Müller & Stefanopoulou, 2006). In addition to the electrochemical reaction models, 1D and 3D models that take into account the effects of coupled heat and mass transfer were generated (Falcao et al, 2011).

In this study, one dimensional and three dimensional thermal models for modelling the thermal behaviour of a cell (an air-cooled Horizon H-500XP), verified by experimental test results, were created by calculating the total heat generation of the stack. The error margins of the models were compared with the experimental test results.

## Materials and Methods

The thermal models and experimental tests were investigated at stack currents of 10, 15, 20 A and ambient temperature of 10 °C. Determining the heat generated by a single cell of the Horizon H-500XP is the first step in modelling the thermal behavior. The calculated heat generation was used as an input parameter in one and three dimensional thermal analysis. Horizon H-500XP has different air flow rates at different stack currents through its two different fans. Therefore, the calculation of different heat transfer coefficients under different stack currents is required. Due to the cell geometry, the equations applied to the flat plates were used. Reynolds and Nusselt numbers were calculated according to air flow rates at each flow rate condition.

$$Re_L = \frac{\rho \cdot v \cdot x}{\mu} \quad (1)$$

In the given equation,  $\rho$  is the density,  $v$  is the velocity,  $x$  is the characteristic length, and  $\mu$  is the dynamic viscosity. In case of laminar or turbulent flow, the appropriate flow equation for the Nusselt number is represented as follows:

$$\text{Laminar} \quad Nu = 0.664 * Re_L^{0.5} * Pr^{1/3} \quad (2)$$

$$\text{Turbulent} \quad Nu = 0.037 * Re_L^{0.8} * Pr^{1/3} \quad (3)$$

The heat transfer coefficient was calculated under the given conditions.

$$Nu = \frac{h \cdot x}{k} \quad (4)$$

In the given equation,  $k$  is the thermal conductivity.

## Heat Generation

Two different approaches were used in this study to calculate the heat generation of a single cell. The approaches are the thermodynamic heat generation equation based on energy balance and the power loss obtained from experimental test results.

$$\dot{Q}_{generation} = (E - V_{cell}) \cdot I \quad (5)$$

In the given equation,  $V_{cell}$  is cell voltage,  $I$  is current, and  $E$  is the maximum voltage that can be obtained if the enthalpy of hydrogen in a cell is converted into electrical energy. The low temperature value of  $E$  is included in the equation as 1.25 V. Current and voltage can be obtained from the datasheet of the product used and the power supply during the tests.

The heat generation calculated using the power loss is determined using the energy content of hydrogen.  $H_2$  generates 178.2 W energy at 1 L/min. In the experimental tests, the flow rate of hydrogen consumed in each stack current was measured. The total output energy obtained from the power supply is subtracted from the

total energy released by the consumed hydrogen. The difference is the energy that can be converted into heat. It is assumed that all cells generate equal amounts of heat and the heat generation per cell was calculated accordingly.

**Table 1.** Model parameters

Parameters	Values
Density	2240 kg/m <sup>3</sup>
Specific heat	710 J/kg.K
Thermal conductivity	20 W/m.K
Stack currents	10 A, 15 A, 20 A
Ambient temperature	10 °C

**One Dimensional Thermal Model**

One dimensional thermal model was developed using the thermodynamic heat generation equation. The model uses the model parameters, the thermal and geometric parameters of the cell and the environmental parameters to calculate the result of the maximum cell temperature and heat flux. In the model, one cell is modeled as a thermal mass and is prepared using block body assumption instead of complex cell geometry (Figure 1).

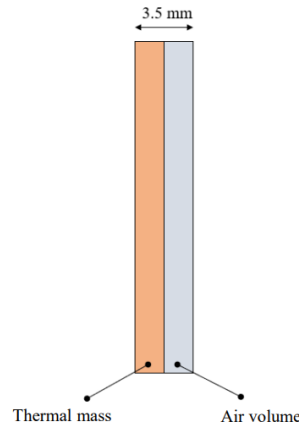

**Figure 1.** One dimensional model cell illustration

The heat generation, thermal mass and forced convection heat transfer were modeled in one dimensional thermal model represented in Figure 2.

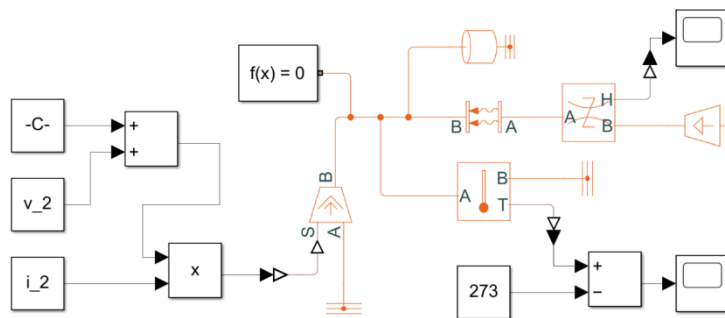

**Figure 2.** One dimensional thermal model

## Three Dimensional Thermal Model

Three dimensional modelling was developed using ANSYS in order to model the complex features of cell geometry, cell components separately, and increase sensitivity. For heat generation, the power loss obtained from the test results and the thermodynamic heat generation were calculated separately and three dimensional analyses were compared. The model uses the cell's thermal, geometric and material parameters to calculate the maximum cell temperature and surface temperature distributions as a result. Steady state approach was used in the model. Figure 3 demonstrates the 3D cell model.

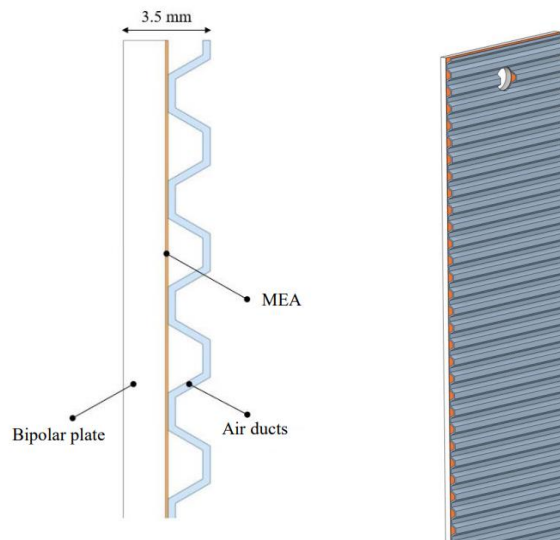

**Figure 3.** Cell geometry

## Experimental Study

Horizon H-500XP is an air-cooled product with peak power of 600 W and has two fans that feed air to the cells. Air flow rates are 0.008, 0.009 and 0.01 m<sup>3</sup>/s under 10, 15 and 20 A stack current conditions respectively. The experimental study was carried out at 10 °C ambient temperature under 10, 15, 20 A stack currents respectively. The pressure of hydrogen was 0.5 bar. Under each current demand, cell surface temperatures were detected using thermal cameras (Figure 4) and maximum cell temperatures were detected using a temperature sensor. The current and voltage outputs were obtained using a power supply. The hydrogen flow rate was detected by using a flowmeter.

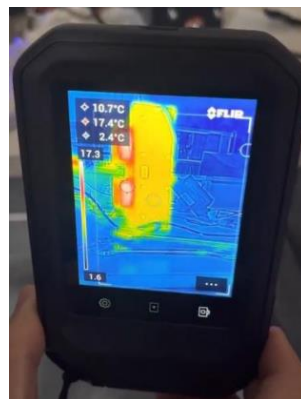
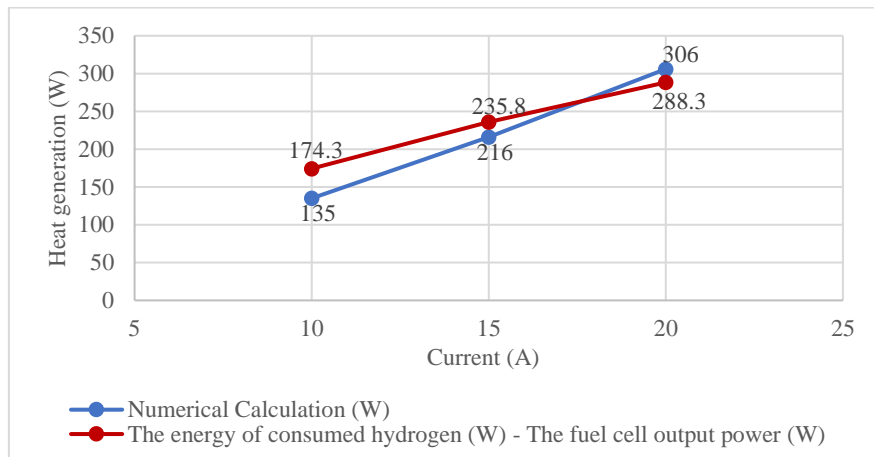

**Figure 4.** Measurement made with a thermal camera



## Findings and Discussion

Initially, the amount of the fuel consumed by the fuel cell under different stack currents is known. The difference between the total power obtained from fuel consumption and the output power detected by the power supply can provide information about the estimated amount of energy that can be converted into heat. Independently, heat generation can be calculated under three different stack currents using the thermodynamic heat generation equation.



**Figure 5.** Comparison of heat generation calculations

Heat generation calculation results were used in one and three dimensional analyses. One dimensional thermal model results are given (Table 3). The results are compared with the experimental test results (Figure 6).

**Table 2.** Experimental test results

Current (A)	Hydrogen consumption (L)	Total power output (W)	Maximum cell temperature (°C)
10	1.96	175	24
15	2.67	240	33
20	3.29	298	42

**Table 3.** One dimensional thermal model results

Current (A)	Maximum cell temperature (°C)
10	24.8
15	32.48
20	40.42

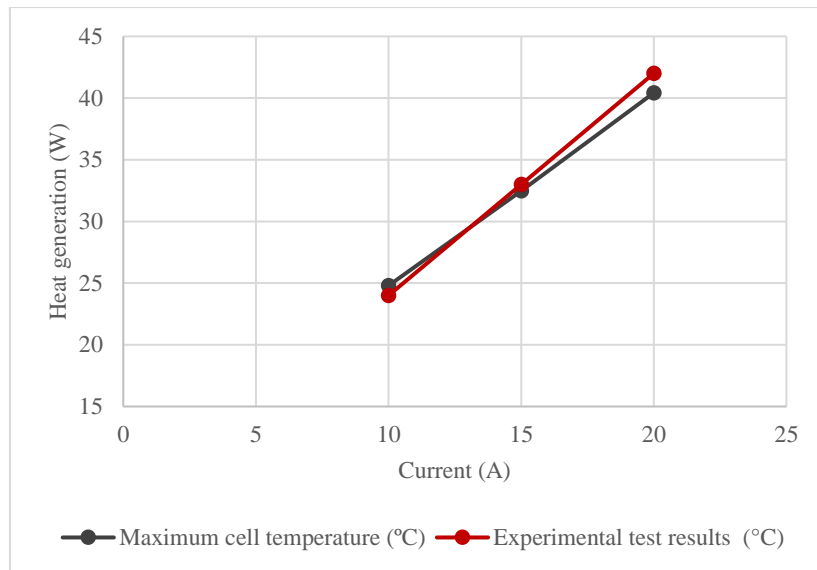
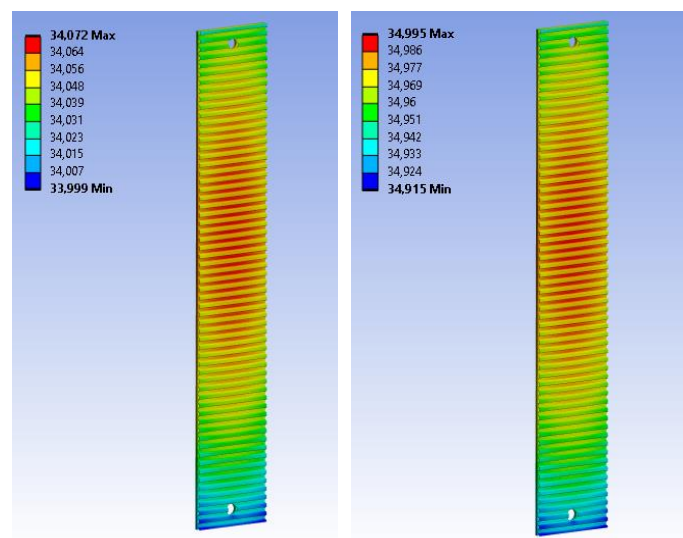

**Figure 6.** Comparison of one dimensional thermal model and experimental test results

Three dimensional thermal results were calculated according to two different heat generation approaches. The analysis results according to the power loss and thermodynamic heat generation equation of the system are given (Table 4). The three dimensional thermal analysis results at 15 A stack current, for which numerical and experimental studies were completed were given in Figure 7.

**Table 4.** Three dimensional thermal model results

Current (A)	Results of 3D thermal model with heat generation calculation approach based on experimental tests (°C)	Results of 3D thermal model with heat generation calculation approach based on thermodynamic analysis (°C)
10	18.62	16.67
15	34.99	34.07
20	45.79	46.58



**Figure 7.** Three dimensional analysis results at 15 A stack current

### Conclusion and Recommendations

In this study, one and three dimensional thermal analysis approaches were developed to analyse the thermal behaviour of an air-cooled PEM fuel cell. The thermal models were generated with the same input parameters. The one dimensional thermal model calculated the cell as a thermal mass, the detailed geometric features were not included in the model. The geometric features of the cell are modeled in detail in three dimensional analyses. In order to model thermal behaviour, heat generation must be detected. In the study, two different methods were investigated to detect the heat generation. Heat generation was assumed to be equal in all cells. Three dimensional thermal analyses were carried out using two different heat generation calculation approaches, the results showed that in the ohmic loss region, the deviation for the maximum cell temperature between the model and the experimental results ranged from 1.5% to 4% for the one dimensional model and from 3% to 11% for the three dimensional model.

### Thanks and Information Note

The authors thank Mert Ali ÖZEL for supporting them with his vast knowledge and experience.

### References

- Dresselhaus, M. & Thomas, I. (2001). Alternative energy technologies. *Nature*, 414, p.332-337.
- Dawood, F., Anda, M. and Shafiullah, G. (2020). Hydrogen production for energy: An overview. *International Journal of Hydrogen Energy*, 45, p.3847-3869.
- Jian, Q., Huang, B., Luo, L., Zhao, J., Cao, S. and Huang, Z. (2018). Experimental investigation of the thermal response of open-cathode proton exchange membrane fuel cell stack. *International Journal of Hydrogen Energy*, 43, p.13489-13500.
- Müller, E. & Stefanopoulou, A. (2006). Analysis, Modelling, and Validation for the Thermal Dynamics of a Polymer Electrolyte Membrane Fuel Cell System. *Journal of Fuel Cell Science and Technology*, 3, p.99-110.
- Falcao, D., Gomes, P., Oliveira, V., Pinho, C. And Pinto, A. (2011). 1D and 3D numerical simulations in PEM fuel cells. *International Journal of Hydrogen Energy*, 36, p.12486-12498.
- Yarts, V. & Lototsky, M. (2004). An Overview of Hydrogen Storage Methods. *Hydrogen Materials Science and Chemistry of Carbon Nanomaterials*, 1, p.75-104.
- Saxena, S. & Verma, A. (2015). Modelling the PEM fuel cell cathode. *International Advanced Research Journal in Science, Engineering and Technology (IARJSET)*, 2, p.205-209.
- Hmad, A. & Dukhan, N. A Cooling design for an end cell in fuel-cell stack using forced air flow in metal foam: Modelling and Experiment. *IOP Conf. Series: Materials Science and Engineering*, 1190, 012008. DOI: 10.1088/1757-899X/1190/1/012008.



## A NEW APPROACH TO WASTEWATER TREATMENT: MICROBIAL FUEL CELLS

**Tuba ARTAN ONAT**

Asst. Prof., Niğde Ömer Halisdemir University, Faculty of Science and Arts, Department of Biotechnology, Niğde-Türkiye  
ORCID: 0000-0003-0300-9855

**İlknur ERKİLİNÇ**

Graduate Student, Niğde Ömer Halisdemir University, Faculty of Science and Arts, Department of Biotechnology, Niğde-Türkiye  
ORCID: 0009-0008-6356-6761

### ABSTRACT

Fossil fuels have been crucial to industrialization up until this point. Due to the rise in energy consumption, there is a worldwide catastrophe with climate change and environmental harm as a result of the increased usage of fossil fuels. Aquatic ecosystems have suffered significant damage as a consequence. Energy sources which are environmentally friendly and sustainable are now starting to be performed in the aim to reduce the energy crisis. Alternative energy sources are being studied for minimizing the complexity of wastewater treatment and the utilization of non-renewable energy sources. Microbial fuel cells (MFCs) are a technology that uses microorganisms to directly convert chemical energy found in organic wastes into electrical energy. MFC, a technology that can simultaneously produce energy and reduce wastewater problems, is still being researched. Due to its low energy requirements, self-sufficiency, and ability to remove more than 90% of chemical oxygen demand (COD) and biological oxygen demand (BOD), microbial fuel cells are gaining attention in the wastewater treatment industry. The performance of the MFCs power generation can be improved by using mixed cultures and reducing the electron transfer resistance. The biofilms are described as microbial communities embedded in their own extracellular matrix (ECM), which is made up of extracellular polysaccharides, extracellular DNA, proteins, and lipids. These communities are associated with material surfaces. Numerous bacteria in the biofilm have improved metabolic processes that enable them to produce electricity more effectively. Complex microbial structures can be observed among the sediment biofilms of lakes. As a result, sedimental biofilms are being used more often in MFCs. Metagenomic techniques are used to determine the microbial structure in biofilms. Environmental DNA (eDNA), enzymes, and associated gene areas that are engaged in metabolic processes are the main topics of metagenomic study. The identification of both uncultured and unknown bacteria can be achieved via eDNA. Therefore, it is feasible to determine the effectiveness of the biofilm utilized in MYH and find out how the microbial metabolism affects the production of electrical energy. The intention of this research is to make it easier to understand the microbial species that are found while analyzing biofilms for MYH using metagenomic techniques.

**Keywords:** Microbial fuel cells, Biofilm, Metagenomic analysis, Wastewater treatment



## SUSTAINABLE ALGAL BIOECONOMY FOR BIOFUEL

**Furkan BAŞ**

Niğde Ömer Halisdemir University, Faculty of Agricultural Sciences and Technologies Biosystem Engineering  
ORCID ID: <https://orcid.org/0000-0002-1312-6871>

**Öznur Begüm GÖKÇEK**

Niğde Ömer Halisdemir University, Faculty of Engineering, Environmental Engineering  
ORCID ID: <https://orcid.org/0000-0003-1730-2905>

**Hamdi MURATÇOBANOĞLU**

Niğde Ömer Halisdemir University, Faculty of Engineering, Environmental Engineering  
ORCID ID: <https://orcid.org/0000-0002-4720-8090>

**Sevgi DEMİREL**

Niğde Ömer Halisdemir University, Faculty of Engineering, Environmental Engineering  
ORCID ID: <https://orcid.org/0000-0002-5329-591X>

### ABSTRACT

The increase in energy consumption with rapid population growth and industrialization is insufficient to meet the demand for existing energy resources. In addition to the damage, it causes to the environment in fossil fuels, there is a need for an alternative and sustainable energy source due to the rapid depletion. In line with this need, sustainable ecology and sustainable green economy have become one of the most important issues on the global agenda. One of the alternative renewable energy sources is biofuels and is obtained from plants. It can be disadvantageous due to the need for large areas for the production of plants to be used in biofuel production and the time it takes to obtain the product. For this, the use of different resources can turn biofuel production into an advantage. Algae that can be found in various aquatic environments can be used in this area. Algae convert CO<sub>2</sub> and sunlight into energy through photosynthesis and produce oil in the process. In this way, algae can store about 20-30 times more fat compared to plants, since they can increase their weight by 3-4 times in a day. These oils obtained can be used directly in the fuel or can be purified and used as biofuel. By increasing the oil production amounts of algae under different conditions, higher yields can be obtained in biofuel production. This study will reveal the importance of the use of algae, which types of algae are appropriate to use as biofuels and what to do about increasing biofuel production.

**Keywords:** Algae, Alternative energy, Biofuel, Sustainable economy and energy.



## AZƏRBAYCANDA ALTERNATİV ENERJİ VƏ ONDAN İSTİFADƏ

**Cəfərov Fazil Tatarxan oğlu, k.t.ü.f.d., dos.v.i.e.**

ADPU-nun Ağcabədi filialı

**Məmmədov Sabir Rüstəm oğlu, p.ü.f.d., dosent**

ADPU-nun Ağcabədi filialı

### XÜLASƏ

Məqalədə Azərbaycanda alternativ enerji və ondan səmərəli istifadə yolları göstərilir. Külək enerjisindən istifadə olunması üçün bütün ərazilərdə küləkli günlərin sayının, küləklərin istiqamətinin müəyyən edilməsindən, Böyük Qafqaz, Kiçik Qafqaz və Talış dağlarında axan kiçik dağ çayları üzərində su elektrik stansiyaları (SES-dən), Günəş enerjisi sistemlərinin əlverişli xüsusiyyətləri qeyd olunur.

Müxtəlif növ biokütlələrin köməyi ilə alınan qazalara isə bioqaz deyilir. Biokütlə enerjisi biokütlənin yandırılması zamanı alınan enerjidir.

Qarabağ "Yaşıl enerji" zonası kimi elan edilmişdir. Qarabağ və ətraf regionların hidroenerji, günəş, külək, enerji kimi bərpa olunan enerji mənbələrinin istifadə olunması nəzərdə tutulur.

Keçmişdə istifadə edilən enerji mənbələrinin tədricən tükənməsi, onlardan istifadə zamanı ətraf aləmə dəyən böyük ziyan hazırda bütün dünyada olduğu kimi, Azərbaycanda da alternativ enerjiden istifadə olunmasına şərait yaradır.

**Acar sözlər:** Alternativ enerji, Günəş enerjisi, Külək enerjisi, Biokütlə enerjisi, Ətraf mühitin qorunması

## ALTERNATIVE ENERGY AND ITS USE IN AZERBAIJAN

### SUMMARY

The article shows alternative energy in Azerbaijan and ways to use it effectively. For the use of wind energy, the number of windy days in all areas, the direction of winds, hydroelectric power stations (SES) on small mountain rivers flowing in the Greater Caucasus, Lesser Caucasus and Talysh mountains, favorable features of solar energy systems are mentioned.

Gases obtained with the help of different types of biomass are called biogas. Biomass energy is the energy obtained during the burning of biomass.

Karabakh has been declared as a "Green Energy" zone. It is planned to use renewable energy sources such as hydropower, sun, wind, energy of Karabakh and surrounding regions.

The gradual exhaustion of the energy sources used in the past, the great damage caused to the environment during their use, as is the case all over the world, creates conditions for the use of alternative energy in Azerbaijan.

**Keywords:** Alternative energy, Solar energy, Wind energy, Biomass energy, Environmental protection

### Giriş

Ta qədim zamanlardan, insanların enerjiyə olan tələbatları, yaranmışdır. Od istilik, işıq mənbəyi, düşmənlərdən qorumaq, müalicə mənbəyi və s. kimi vasitə olmuşdur. Bu baxımdan insanlar üçün od həmişə müqəddəs olmuşdur. İnsan cəmiyyəti inkişaf etdikcə sənaye və kənd təsərrüfatı sahələri sürətlə artmış və enerjiyə ehtiyac yüksəlmişdir. Bu gün bəşəriyyətdə qlobal problemlərdən biri yanacaq ehtiyatlarından

dayanmadan istifadə olunmasıdır. Hətta XXI əsrdə dünyanın bəzi ölkələrində kənd yerlərində məskunlaşan əhalinin əksəriyyəti hələ də müasir enerjiden istifadə etmək imkanına malik deyil. Dünyanın demək olar ki, bütün ölkələri öz enerji ehtiyaclarını neft, təbii qaz və kömür kimi ənənəvi enerji mənbələri hesabına ödəyir. Bu resurslar isə tükənəndir, ətraf mühiti çirkləndirəndir, qiymətləri bahadır. Bunun əksi olaraq alternativ enerji mənbələri ekoloji cəhətdən təmiz və tükənməzdir. Proqnozlara görə yaxın 15-20 il ərzində bərpa olunan enerji mənbələri dünya energetika balansında görkəmli yer tutmalı, tükənməkdə olan üzvi yanacaq ehtiyatlarının əvəzlənməsini və ətraf mühitin ekoloji sağlamlaşdırılmasını təmin etməlidir. Alternativ energetika təkcə ətraf mühitin mühafizəsi üçün vacib deyil. Eyni zamanda omum səmərəli olmasıdır.

### Təhlil və müzakirə

*Azərbaycanda külək enerji mənbələrindən istifadə.* **Külək enerjisi** küləyi meydana gətirən hava axınının sahib olduğu hərəkət enerjisidir. Alternativ enerji (bərpa olunan) mənbələrindən biri hesab olunur. Bu enerjinin bir hissəsi faydalı olan mexaniki və ya elektrik enerjisinə çevrilə bilər. Külək enerjisi digər alternativ enerji mənbələri olan günəş, hidroenergetika, geotermal və biokütlə enerjisindən özünün maya dəyərində, ekoloji təmizliyinə və tükənməzliyinə görə ən sərfəlisidir. Külək gücündən ilk faydalanma yelkənli gəmilər və yel dəyirmanları göstərilə bilər. Daha sonra taxıl üyüdmə, su nasosla vurma, ağac kəsmə işləri üçün də külək gücündən faydalanılmışdır. İndiki vaxtda daha çox elektrik çıxarmaq məqsədiylə istifadə edilməkdədir. Elektrik enerjisi istehsalı üçün daha səmərəli texnologiyalardan biridir. Külək enerjisindən istifadə olunması energetikanın daha tez inkişaf edən sahələrindən biridir. Külək enerjisinin enerjiyə çevrilməsi əsasən 2 mühüm tədbirin həyata keçirilməsini tələb edir:

- ✓ Müvafiq maliyyə, material sərfi vasitəsilə daimi olmayan külək enerjisinin toplanması;
- ✓ Müxtəlif ərazilərdə enerji almaq üçün külək mühərriklərindən istifadə edilməsi.

Azərbaycan Respublikası bu cəhətdən olduqca əlverişli şəraitə malikdir [1:2]. Külək enerjisindən istifadə edilməsinin təşkilatı məsələləri istehsal proseslərinin bütün sahələrini əhatə edir. Enerji istifadənin təkmilləşdirilməsi və kompleks inkişafı bəzi məsələlərin həyata keçirilməsini tələb edir:

- ✓ Enerji potensialının iqtisadi səmərəsinin artırılması;
- ✓ Enerji istehlakında elektrik enerjisi payının fasiləsiz artırılması;
- ✓ Elektrikləşdirmənin rolunun və əmək məhsuldarlığının yüksəldilməsi;
- ✓ Mütərəqqi texnoloji tədbirlərin həyata keçirilməsi;
- ✓ Keyfiyyətin və əhalinin rifah halının yaxşılaşdırılması.

*Alternativ enerji kimi SES-lərdən istifadə.* Azərbaycan çaylarının ümumi hidroenerji potensialının 40 mvt/saat, kiçik su elektrik stansiyaları (SES-lərin) nəzəri enerji potensialının isə 28 mlrd.kvt./saat olduğu müəyyən edilmişdir. İlk hesablamalara görə, çayların üzərində tikilməsi mümkün olan 280-ə yaxın kiçik SES-in ümumi istehsal gücü 700 MVT, illik enerji istehsalı isə 3,2–3,5 mlrd.kvt/saat təşkil edir. Respublika ərazisində 140-dan çox su anbarı var və bu su anbarlarından yalnız 61-nin həcmi 1 mln. m<sup>3</sup>-dən çoxdur. Su anbarlarının ümumi tam həcmi 21,5 km<sup>3</sup> təşkil edir. Kür, Araz və Tərtər çaylarında yaradılmış su anbarları və SES-lər – Şəmkir, Mingəçevir, Yenikənd, Varvara, Araz və Sərsəng kompleks təyinatlı su təsərrüfatı obyektləridir və energetika, suvarma, su təchizatı və s. üçün istifadə olunurlar. Respublikanın ən iri Mingəçevir su anbarı 1953-cü ildə istismara verilib, çoxillik tənzimləmə rejimində işləyir, Kür çayının axımı onun aşağı axımında tamamilə tənzimlənib və subasma hallarının qarşısı alınıb. Böyük su anbarları ("Mingəçevir", "Şəmkir", "Araz su qovşağı", "Sərsəng") kompleks əhəmiyyətə malik olduğu halda, digər su anbarlarının əksəriyyəti irriqasiya məqsədi ilə tikilmişdir.

Sərsəng su anbarı — Azərbaycana məxsus 1976-cı ildə Tərtərçayın üzərində, keçmiş Ağdərə, indiki Tərtər rayonu ərazisində, inşa edilmiş su anbarı Onun ümumi su tutumu 560 mln m<sup>3</sup>, bəndinin hündürlüyü isə 125 m-dir. Sərsəng su anbarı respublikanın 6 rayonunun (Tərtər, Ağdam, Bərdə, Goranboy, Yevlax və Ağcabədi) 100 min hektara yaxın torpaq sahəsini suvarma suyu ilə təmin edirdi. Yalnız Sərsəng su anbarının işgali nəticəsində 100 min hektar sahədə kənd təsərrüfatı bitkilərinə suvarma suyunun verilməməsi respublikanın bu regionuna əvəz olunmaz zərər vurmuşdur.

*Tükənməyən Günəş enerji mənbərindən istifadə.* Günəş - ətraf mühitə təsirsiz davranan dünyanın tükənməyən ən güclü və təmiz enerji mənbəyidir. Müasir dövrümüzdə günəş enerjisi ən mühüm enerji mənbələrindən biri hesab olunur. Günəş enerjisi sistemlərinin əlverişli xüsusiyyətləri: - Ətraf mühitə zərər vermir; - İstifadəsində çox aşağı xərc tələb edir; - Asanlıqla tətbiq edilə bilər; Günəş enerjisi sistemlərindən - isti su təmini, binaların isidib soyudulmasında, buxar əldə edilməsində, elektrik istehsalında, saf su və duz istehsalında və s. istifadə edilir. Ənənəvi enerji mənbələrinin tədricən tükənməsi, həmçinin, onlardan istifadə zamanı ətraf mühitə vurulan külli miqdarda ziyan hazırda bütün dünyada olduğu kimi, Azərbaycanda da alternativ enerji növlərindən istifadə zərurətini yaradır.

Yer səthinə düşən günəş enerjisinin miqdarı bütün neft, qaz, kömür və digər yanacaq ehtiyatlarından çoxdur. Günəş enerjisinin istifadəsinin üstünlüyü ondadır ki, Günəş qurğuları işləyən zaman parnik effekti yaranmır, havanın çirklənməsi baş vermir, istilik aşağı atmosfer qatlarına yayılmır. Günəş enerjisindən passiv və aktiv qurğuların vasitəsi ilə istifadə etmək mümkündür. Passiv sistemlərdə günəş enerjisi şüalanmanın, istilikkeçirmənin və təbii ventilyasiyanın köməyi ilə ötürülür. Aktiv sistemlərdə isə, günəş şüaları ilə qızan səthin istiliyi istilikdaşıyıcısının vasitəsilə digər qurğuya nəql edilir. Bu zaman istiliyi qəbul etmək üçün günəş kollektorlarından istifadə edilir. Günəş panelindən maksimum elektrik enerjisi almaq üçün günəşli hava daha yaxşıdır. Amma bu o demək deyil ki, buludlu, yağışlı havada enerji istehsal edilməyəcək[3:4]. Günəş panelləri ən buludlu havada belə 50 faiz güclə işləyir. Azərbaycanın təbii iqlim şəraiti günəş enerjisindən istifadə etməklə elektrik və istilik enerjisinin istehsalını artırmağa geniş imkanlar açır.

*İşğaldan azad olunmuş ərazilərdə “Yeni Enerji” layihələri.* Qarabağda yenidənqurma və bərpa işləri sırasında ən mühüm yeri ərazilərin elektrik enerjisi ilə təmin edilməsi, bərpa olunan və yeni enerji mənbələrinin yaradılması tutur. Bütövlükdə, Qarabağ “Yaşıl enerji” zonası kimi elan edilmişdir. İlk olaraq Kəlbəcər, Laçın, Qubadlı, Zəngilan, Cəbrayıl, Füzuli rayonlarının ərazisində yüksək günəş enerjisi potensialına malik ümumi sahəsi 14 427 ha olan 8 potensial ərazi seçilmişdir. Bu ərazilərdə ümumilikdə 7214 MVt gücündə günəş elektrik stansiyalarının yerləşdirilməsi mümkün görünərsə də, cənub ərazilərin bir hissəsinin kənd təsərrüfatı təyinatlı ola biləcəyi nəzərə alınaraq, burada ümumi potensial 4000 MVt-dan yüksək qiymətləndirilir. Kəlbəcər və Laçın rayonlarının külək enerjisi resursları nəzərdən keçirilib. Qarabağın dağlıq ərazilərində külək enerjisinin potensialı 500 meqavatdan yüksək qiymətləndirilir və bu potensialın böyük hissəsi adıçəkilən rayonların Ermənistanla sərhəd zonalarına düşür. Belə böyük potensiala baxmayaraq, əlverişli infrastrukturun olmaması səbəbindən bu sahələrdə külək enerjisindən elektrik enerjisinin hasil edilməsi məsələsinin yerində araşdırma və tədqiqat işləri tələb edir. Azərbaycanda 25% yerli su ehtiyatlarının Qarabağda formalaşdığı nəzərə alınmaqla, Tərtər, Bazarçay, Həkəri kimi əsas çaylar və onların qollarından elektrik enerjisi istehsalı məqsədi ilə istifadə perspektivləri vardır. Su elektrik stansiyaları əsasən Tərtər, Laçın və Kəlbəcər rayonlarının ərazisində yerləşir. Zəngilan rayonunda ilk “Ağıllı kənd”in inşası başa çatmışdır. Bu kənd azad olunmuş ərazilərə Qayıdışın ilk məntəqəsi olacaq. Kəndin inşasında çoxsaylı innovativ yanaşmalar tətbiq olunub. Kənddə enerjiyə tələbat “Yaşıl enerji” sistemi ilə təmin edilib. Dayanıqlı enerji təminatı Həkəri çayı üzərində inşa olunan su elektrik stansiyaları vasitəsilə həyata keçiriləcək. “Ağıllı kənd”də evlərin dam hissəsində yerləşdirilən vaakum Günəş kollektorları vasitəsilə enerji toplanaraq evlərin və suyun qızdırılmasında istifadə ediləcək.

*Biokütlə enerjisi.* Biokütlə - bir enerji mənbəyi olub, günəş enerjisini fotosintez olaraq toplayan bitki mənşəli orqanizmlərdir. Sənaye mənasında biokütlə dedikdə bioloji maddələrdən yanacaq əldə edilməsi və ya sənayenin digər sahələrində istifadəsi başa düşülür. Belə ki, yanacaq əldə etmək məqsədilə yetişdirilən bitkilər ilə lif, istilik və kimyəvi maddələr almaq üçün isə heyvani və bitki mənşəli məhsullar istifadə olunur. Biokütlə enerjisindən alınan istilik miqdarı odunun yanmasından alınan istilik miqdarından yüksəkdir. Ümumiyyətlə bu enerjiden qədim zamanlardan istifadə edilir. Müxtəlif növ biokütlələrin köməyi ilə alınan qazalara isə bioqaz deyilir. Biokütlə enerjisi biokütlənin yandırılması ilə alınan enerjidir[5:6]. Bu xüsusiyyət biokütlədən enerji alınmasında ən önəmli üstünlüyüdür. Biokütlədən müxtəlif üsullarla biodizel, bioqaz, etanol, metan, üzvi gübrə və bu kimi digər maddələr və məhsullar əldə edilməkdədir. Biokütlədən alınan maddələri müxtəlif hazırlıq və çevrilmə proseslərindən keçirərək bioyanacaqlar əldə edirlər.

### Nəticə

Məqalədə əsasən elektrik və istilik enerjisi istehsalına, enerjiden səmərəli istifadəyə, enerji təchizatının effektivliyini artırılması və istehlakçıların dayanıqlı enerji təminatını əldə olunması barədə ətraflı məlumatların



verilməsində ibarətdir. Bunun üçün, enerji mənbələrinin diversifikasiyası, istilik effekti yaradan qaz tullantılarının azaldılması, zəruri tədbirlər həyata keçiriləcəkdir. Ölkənin enerji təhlükəsizliyində və ümumi elektrik enerjisi istehsalında alternativ və bərpa olunan enerji mənbələrinin rolunun artırılması;

Alternativ enerji mənbələrindən (AEM-dən) istifadə etməklə enerji istehsalı və istehlakının artırılması, bu hesaba digər enerji resurslarından səmərəli istifadə və enerji istehsalı prosesi zamanı yaranan texnogen təsirlərin ətraf mühitə vurduğu ziyanın səviyyəsinin azaldılmasının təmin olunması;

- ✓ AEM-dən istifadə olunması neft və qaz xammallarının neft – kimya sənayesinə yönəldilməsi;
- ✓ AEM-nin tətbiqi sahəsində innovativ texnologiyalardan istifadənin geniş tətbiq edilməsi və beynəlxalq təcrübələrin mənimsənilməsi;
- ✓ Bioqaz enerjisinin heyvandarlıq inkişaf etmiş ərazilərdə alınması və istifadəsi;
- ✓ AEM-nin istifadəsi neft və qaz kimi ənənəvi enerji resurslarından istifadədə enerji təhlükəsizliyinin təmin olunmasını;
- ✓ Azərbaycan şəraitində AEM-dən geniş istifadə olunması ənənəvi yanacaqlardan asılılığın xeyli azalmasına səbəb olması; (enerji diversifikasiyası)

### **İsifadə olunmuş ədəbiyyat siyahısı:**

1. Azərbaycan Respublikasının enerji resursları haqqında qanunu. Bakı -1996
2. Ç.M.Çüvarlı, V.İ.Jesman – Külək və günəş enerjisi onun çevrilməsi və istifadəsi. Bakı – 2003
3. R.İ.Talışinski, N.M.Əliyev, L.H.Həsənova, R.L.Əlizadə - Bərpa olunan saf enerji mənbələri. Bakı
4. S.Q.Əmirov, M.V.Abdulayeva – Külək və günəş enerjisindən istifadə ilə təbii ehtiyatlara qənaət. Bakı
5. R.Əliyev – Alternativ enerji və Ekologiya. Bakı
6. M.F.Cəlilov – Alternativ enerji sistemləri. Bakı



### SMART HOME PROGRAMMING FOR IMPROVING SUSTAINABILITY IN RESIDENTIAL AREAS

**Abdussalam Ali Ahmed**

Assistant Professor, Department of Mechanical Engineering, Faculty of Engineering, Bani Waleed University, Bani Waleed, Libya,  
ORCID: <https://orcid.org/0000-0002-9221-2902>

**Abdulgader Alsharif**

Department of ElectricElectrical and Electronic Engineering, Faculty of Technical Sciences Sebha-Sebha-Libya

**Mohammed Khaleel**

Research and Development Department, College of Civil Aviation, Misrata, Libya

**Yassar F. Nassar**

Mechanical & Renewable Energy. Engineering Department, Wadi Alshatti University, Brack-Libya

**Mohamed Alamen Sharif**

Department of Renewable Energy Engineering, Faculty of Engineering, Sebha University, Libya

**Hala Jarallah El-Khozondar**

Electrical Engineering Department, Islamic University of Gaza, Gaza, Palestine

#### ABSTRACT

The applications of smart homes received attention due to their popularity and accessibility of using modern technology such as the Internet of Things (IoT). Reducing greenhouse gas (GHG) emissions and addressing climate change depend heavily on residential buildings' increased energy efficiency and sustainability. Programming smart homes, which use cutting-edge technologies and automation systems to optimize energy use and improve occupant comfort, is one way to accomplish sustainability. Smart meters, sensors, actuators, and communication networks are just a few of the systems and components that must be integrated into a smart home's programming. The aforementioned elements work together to gather information on energy use, occupancy patterns, and environmental factors. The studied data is then used to guide the programming choices for the home's heating, cooling, lighting, and other energy-consuming equipment. Utilizing the proper programming software is also a significant component. This study presents various programming languages that enable smart devices to work efficiently.

**Keywords:** Internet of Things, Sustainability, Programming smart homes, Cutting-edge technologies, Programming languages.

#### 1. Introduction

Energy efficiency and sustainability can be improved with smart home programming. Writing code to manage and automate various home systems and gadgets is a component of programming for smart homes [1]. This could include controlling lights, thermostats, security systems, appliances, entertainment systems, and more [2]. Programming a smart home involves designing and writing software code that controls and automates various devices and systems within the home [3]. This can include smart lights, thermostats, security cameras, door locks, appliances, and entertainment systems [4]. The area of smart programming and intelligent devices in smart homes is interesting due to the need for gaining a more sustainable life and the comfort that people looking for [5]. Based on the aforementioned statement, several steps can be followed in order to program smart home devices intelligently.

In the literature, various conducted studies have been taken into consideration smart home programming. To program a smart home application, the programmer needs to familiarize with different languages, platforms,

and protocols. Besides, understanding the specific Application Programming Interfaces (APIs) and Software Development Kits (SDKs) provided by device manufacturers or Internet of Things (IoT) platforms [6]. It is also important to know about networking, security, and data management principles as smart homes involve the exchange of sensitive data and must be secure from cyber threats [7]. By considering programming strategies for smart homes, energy efficiency can be significantly improved. For instance, occupancy sensors can detect when occupants are present or absent in a particular room and adjust the heating or cooling accordingly.

Lighting systems can be programmed to automatically turn off when no one is in the room or adjust the intensity based on natural lighting conditions [3]. Similarly, smart home appliances can be programmed to operate during off-peak hours when electricity demand is lower, reducing the strain on the grid and potentially lowering energy costs [8]. In addition to energy efficiency, sustainability can also be enhanced through smart home programming [9]. Integration with renewable energy sources such as solar panels or small wind turbines can be optimized to maximize energy generation and consumption within the home [10], [11]. This can include programming the charging of Electric Vehicles (EVs) during periods of peak solar generation or diverting excess energy to the grid for others to use [12].

Furthermore, the programming of smart homes can enable demand response capabilities, allowing homeowners to participate in energy management programs offered by utilities [3]. This means that during times of high electricity demand, the home's energy consumption can be automatically adjusted, reducing strain on the grid and supporting grid stability. In conclusion, programming smart homes offers significant opportunities for improving energy efficiency and sustainability [13]. By utilizing advanced technologies, data analysis, and automation, energy use can be optimized, and renewable energy integration can be maximized [14]. The aforesaid benefit is not only can reduce environmental impacts but also provides economic benefits to homeowners.

The main contribution of this article is comprehensively discussing the programming languages for smart homes along with the challenges and future direction for future researchers. The rest of the article is classified into four sections as follows: Section 2 discusses the methods and materials of programming a smart home considering the steps for programming of smart home. Features of programming languages and software for smart homes are placed in Section 3. The challenges along with future research direction are tabulated in Section 4. Eventually, the article closed with a conclusion and a list of recent references published in high-impact journals and conferences.

## 2. Methods and materials

There are many approaches that have been deployed in the state-of-the-art for the purposes of programming smart home applications. The different ways of increasing the efficiency and sustainability of smart homes through various forms as figured out in Figure 1 along with further explanation for each application as listed below.

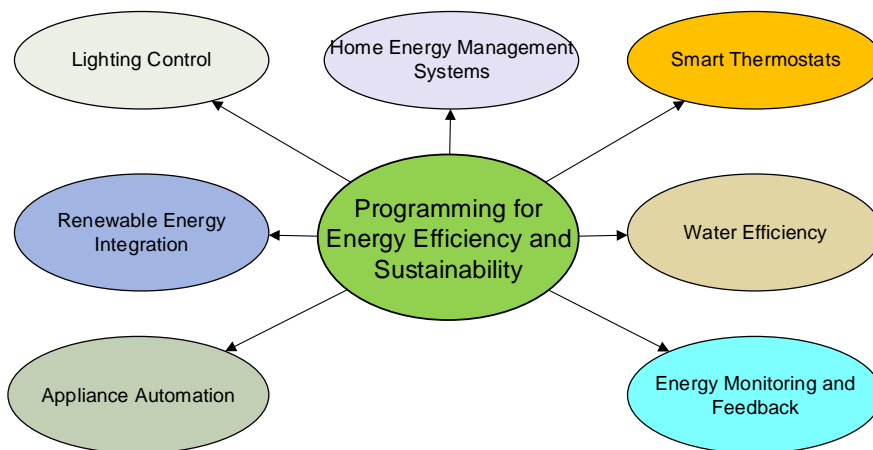

**Figure 1.** Programming for improving energy efficiency and sustainability [3], [16].

- **Lighting Control:** Programming smart lighting systems can automate the turning on and off of lights based on occupancy or time of day, ensuring they are only used when needed. It can also adjust the intensity of lights based on natural light availability, reducing unnecessary energy usage.
- **Home Energy Management Systems:** These systems can monitor energy usage in real time and provide insights on where energy is being wasted. By analyzing this data and making adjustments, homeowners can reduce unnecessary energy consumption.
- **Smart Thermostats:** Programmed thermostats can learn the homeowners' preferences and adjust the temperature, accordingly, optimizing energy consumption. They can also detect when the house is empty and automatically adjust the temperature to save energy.
- **Renewable Energy Integration:** Programming can enable smart homes to dynamically adjust energy consumption based on the availability of renewable energy sources, such as solar power. This helps maximize the utilization of renewable sources and reduces reliance on fossil fuels.
- **Water Efficiency:** Smart home programming can optimize water usage by monitoring and controlling irrigation systems, detecting leaks, and providing real-time feedback on water usage. This helps to conserve water resources and reduce excess water consumption.
- **Appliance Automation:** Through programming, smart appliances can be scheduled to operate during off-peak hours when electricity rates are lower. This reduces the load on the electrical grid during peak times and promotes efficient energy use.
- **Energy Monitoring and Feedback:** Smart home systems can provide real-time energy consumption data, giving homeowners insights into their energy usage patterns. This feedback can help raise awareness and encourage energy-saving habits. By combining these features and leveraging automation through programming, smart homes can significantly reduce energy waste, increase energy efficiency, and promote sustainability.

Some steps to consider when programming a smart home as listed for specific clarification and demonstrated in Figure 2 for further explanation and understanding.

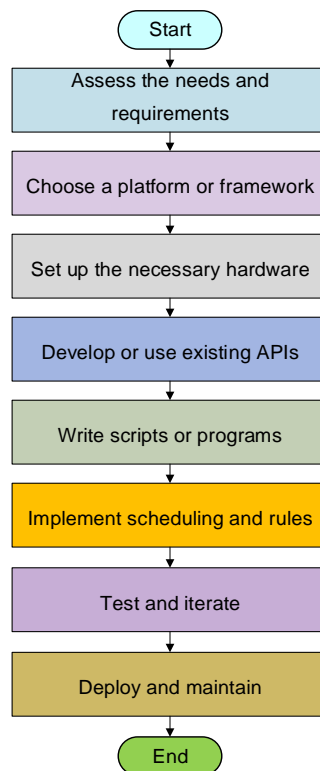
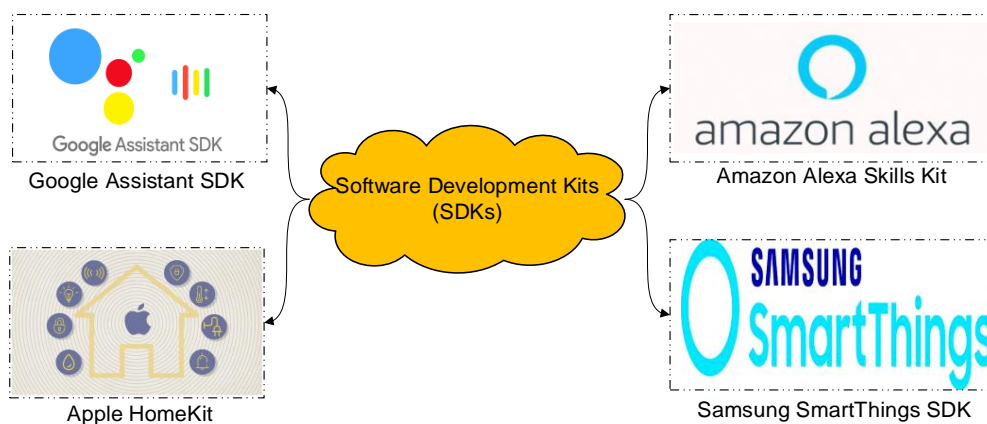

**Figure 2.** Steps for programming smart homes [17].

1. **Assess the needs and requirements:** Determine what devices and systems you want to include in your smart home and what functionalities you want to achieve. This will help guide your programming efforts.
2. **Choose a platform or framework:** Select a platform or framework that supports the devices you want to integrate. Some popular choices include Apple HomeKit, Google Home, Amazon Alexa, or open-source frameworks like Home Assistant.
3. **Set up the necessary hardware:** Install and configure the required hardware devices that will enable communication and control between your smart home devices, such as smart hubs, gateways, or communication protocols like Z-Wave or Zigbee [15].
4. **Develop or use existing APIs:** Use the APIs provided by the devices you intend to integrate to communicate with them if they offer them. If they do, read their documentation. If not, think about utilizing pre-existing software libraries or Software Development Kits (SDKs) that give a unified API and abstract device-specific functionality.
5. **Write scripts or programs:** Use your preferred programming language to write scripts or programs that control and automate the devices in your smart home. These scripts or programs will listen for events, such as user interactions or predefined triggers, and send commands to the devices accordingly.
6. **Implement scheduling and rules:** Use your programming skills to create scheduling logic and rules that automate tasks based on specific conditions or time-based events. For example, you can create rules to turn off the lights when the last person leaves the house or adjust the thermostat based on outdoor weather conditions.
7. **Test and iterate:** Test the functionality of your programs extensively to ensure that they work as intended. Debug any issues and make necessary improvements or adjustments based on user feedback or new requirements.
8. **Deploy and maintain:** Once you are satisfied with the functionality and stability of your smart home programming, deploy it to your home environment. Regularly update and maintain your code as you add or change devices, or when software updates become available for your smart home platform.

### 3. Programming languages and Software

The construction of smart homes frequently makes use of the following programming languages and frameworks. Figure 4 shows several examples of Software Development Kits (SDKs) and frameworks in addition to programming languages, such as the Google Assistant SDK, Apple HomeKit, Amazon Alexa Skills Kit, and Samsung SmartThings SDK. Figure 5 shows the many residential uses. Several application programming interfaces are also shown in Figure 5. The programming languages and frameworks for smart home development along with their symbols are tabulated in Table 1.



**Figure 4.** Software Development Kits [3].



Figure 5. Smart home applications.

Table 1. Programming languages and frameworks for smart home development [3], [18], [19].

Program languages	Features	Symbols
Python	<ul style="list-style-type: none"> <li>• Popular language for smart home programming</li> <li>• Simple and has an extensive library.</li> <li>• Interface with various hardware devices easily</li> <li>• Support IoT protocols such as MQTT.</li> </ul>	
JavaScript	<ul style="list-style-type: none"> <li>• Widely used for web-based smart home applications</li> <li>• It can run in web browsers.</li> <li>• integrate with APIs and cloud services.</li> </ul>	
C/C++	<ul style="list-style-type: none"> <li>• Utilized for low-level programming.</li> <li>• Accessing embedded systems (microcontrollers or hardware interfaces).</li> </ul>	
Ruby	<ul style="list-style-type: none"> <li>• It is a dynamic and expressive language.</li> <li>• used with frameworks like Ruby on Rails to build smart home applications.</li> </ul>	
Swift	<ul style="list-style-type: none"> <li>• Used for iOS app development.</li> <li>• Making it ideal for creating smart home control interfaces and apps for Apple devices.</li> </ul>	
Node.js	<ul style="list-style-type: none"> <li>• It is a runtime environment for executing JavaScript code on the server-side,</li> <li>• making it suitable for building backend services and APIs for smart home systems.</li> </ul>	

4. Open research issues and Challenges

There are several potential and difficulties for future work related to enhancing sustainability in smart home programming as tabulated in Table 2. These difficulties and potential future directions are only a few. Additionally, in order to guarantee the long-term success and broad adoption of environmentally friendly behaviors, future work in smart home programming for improving sustainability needs to address these issues as future directions of study for future researchers as tabulated in Table 3.

**Table 2.** Challenges and future direction of smart home programming.

Challenges	Remarks
Data Privacy and Security	Effective programming for sustainability requires gathering and analyzing vast amounts of data from various sensors and devices in a smart home. However, this raises concerns about data privacy and security.
Interoperability and Standardization	Smart homes often consist of multiple interconnected devices and systems from different manufacturers, which may not be compatible or interoperable. The lack of standardization poses a challenge for efficient programming.
User Engagement and Behavior Change	Sustainable practices heavily rely on user behavior, and programming should support and encourage environmentally friendly actions.
Scalability and Ubiquity	As the adoption of smart homes continues to grow, scalability becomes a significant challenge.
Lifecycle Assessment and Circular Economy	Smart home programming should consider the entire lifecycle of devices, including manufacturing, use, and disposal.
Integration with Energy Grids	Smart homes can play a vital role in supporting the stability and resiliency of the energy grid.

**Table 3** Future direction.

Challenges	Future direction
Data Privacy and Security	Developing robust security protocols and privacy frameworks to ensure safe and ethical handling of data.
Interoperability and Standardization	To establish industry-wide standards to ensure seamless interoperability between different devices and systems.
User Engagement and Behavior Change	Developing personalized and persuasive interfaces, gamification techniques, and behavioral nudges to enhance user engagement and motivate sustainable actions.
Scalability and Ubiquity	How to program and manage large-scale deployments of smart homes to ensure sustainability benefits are not limited to individual households but can be extended to communities and cities.
Lifecycle Assessment and Circular Economy	Incorporate lifecycle assessment methodologies to optimize resource consumption and encourage the adoption of circular economy principles within smart home programming
Integration with Energy Grids	Improving the coordination between smart homes and energy grids, enabling bidirectional energy flow, and facilitating dynamic demand response programs.

## Conclusion

In conclusion, the programming of smart homes is a significant factor in improving energy efficiency and sustainability. By integrating advanced technologies and systems, smart homes can effectively optimize energy usage, reduce waste, and promote sustainable practices. The programming of smart homes enables automation, real-time monitoring, and adaptive controls, which contribute to better energy management and conservation. The main purpose of writing this article is to present the programming languages for smart homes in order to accomplish sustainability development in residential sectors. Furthermore, the intelligent programming of smart homes can facilitate the integration of renewable energy sources and smart grid systems, further enhancing energy efficiency and sustainability. Investing in the programming of smart homes is a crucial step towards achieving a more environmentally friendly and sustainable future.

## References

- [1] H. Uddin *et al.*, “IoT for 5G/B5G applications in smart homes, smart cities, wearables and connected cars,” *IEEE Int. Work. Comput. Aided Model. Des. Commun. Links Networks, CAMAD*, vol. 2019-Septe, pp. 2–6, 2019, doi: 10.1109/CAMAD.2019.8858455.
- [2] A. Alsharif, R. Y. Jomah, A. Alshareef, M. Almihat, A. Salah, and A. Al Smin, “Hybrid Systems

- Renewable Energy Based Street Lighting Planning: A Case Study,” *African J. Adv. Pure Appl. Sci.*, vol. 1, no. 1, pp. 31–40, 2022.
- [3] R. Majeed, N. A. Abdullah, I. Ashraf, Y. Bin Zikria, M. F. Mushtaq, and M. Umer, “An Intelligent , Secure , and Smart Home Automation System,” vol. 2020, 2020.
- [4] M. K. Daryabari, R. Keypour, and H. Golmohamadi, “Robust self-scheduling of parking lot microgrids leveraging responsive electric vehicles,” *Appl. Energy*, vol. 290, p. 116802, May 2021, doi: 10.1016/j.apenergy.2021.116802.
- [5] G. Dileep, “A survey on smart grid technologies and applications,” *Renew. Energy*, vol. 146, pp. 2589–2625, Feb. 2020, doi: 10.1016/j.renene.2019.08.092.
- [6] A. Mayub, Fahmizal, M. Shidiq, U. Y. Oktiawati, and N. R. Rosyid, “Implementation smart home using internet of things,” *Telkomnika (Telecommunication Comput. Electron. Control.*, vol. 17, no. 6, pp. 3126–3136, 2019, doi: 10.12928/TELKOMNIKA.v17i6.11722.
- [7] I. Duic, V. Cvrtila, and T. Ivanjko, “International cyber security challenges,” *2017 40th Int. Conv. Inf. Commun. Technol. Electron. Microelectron. MIPRO 2017 - Proc.*, pp. 1309–1313, 2017, doi: 10.23919/MIPRO.2017.7973625.
- [8] M. K. ; Z. Yusupov; , A. ; A. Ali, A. ; Ahmed, and Imbayah ; Ibrahim, “The Effect of Digital Technologies on Energy Efficiency Policy,” 2023.
- [9] H. Kim, H. Choi, H. Kang, J. An, S. Yeom, and T. Hong, “A systematic review of the smart energy conservation system: From smart homes to sustainable smart cities,” *Renew. Sustain. Energy Rev.*, vol. 140, p. 110755, Apr. 2021, doi: 10.1016/j.rser.2021.110755.
- [10] A. Info *et al.*, “A Review of the Smart Grid Communication Technologies in Contactless Charging with Vehicle to Grid Integration Technology,” *J. Integr. Adv. Eng.*, vol. 1, no. 1, pp. 11–20, Apr. 2021, doi: 10.51662/jiae.v1i1.8.
- [11] M. Khaleel, A. A. Ahmed, and A. Alsharif, “Artificial Intelligence in Engineering,” *Brill. Res. Artif. Intell.*, vol. 3, no. 1, pp. 32–42, Mar. 2023, doi: 10.47709/brilliance.v3i1.2170.
- [12] S. Home, *applied sciences A Systematic Content Review of Artificial Intelligence and the Internet of Things Applications in Smart Home.*
- [13] A. A. Ahmed, M. Belrzaeg, Y. Nassar, H. J. El-khozondar, and M. Khaleel, “A comprehensive review towards smart homes and cities considering sustainability developments , concepts , and future trends,” 2023, doi: 10.30574/wjarr.
- [14] M. Terkes, S. M. Tercan, A. Demirci, and E. Gokalp, “An Evaluation of Renewable Fraction Using Energy Storage for Electric Vehicle Charging Station,” in *2022 International Congress on Human-Computer Interaction, Optimization and Robotic Applications (HORA)*, IEEE, Jun. 2022, pp. 1–10. doi: 10.1109/HORA55278.2022.9800091.
- [15] A. Samanta and S. S. Williamson, “A survey of wireless battery management system: Topology, emerging trends, and challenges,” *Electron.*, vol. 10, no. 18, p. 2193, Sep. 2021, doi: 10.3390/electronics10182193.
- [16] I. Alsharif, H. E. Hebrisha, and A. A. Ahmed, “A Comprehensive Review Towards Libyan Smart Cities,” *African J. Adv. Pure Appl. Sci.*, vol. 2, no. 3, pp. 15–22, 2023.
- [17] P. D. P. Adi and A. Kitagawa, “A Review of the Blockly Programming on M5Stack Board and MQTT Based for Programming Education,” *Proc. 2019 IEEE 11th Int. Conf. Eng. Educ. ICEED 2019*, pp. 102–107, 2019, doi: 10.1109/ICEED47294.2019.8994922.
- [18] C. Stolojescu-Crisan, C. Crisan, and B. P. Butunoi, “An iot-based smart home automation system,” *Sensors*, vol. 21, no. 11, pp. 1–23, 2021, doi: 10.3390/s21113784.
- [19] S. Tockey and D. Shiffman, “The Nature of Code,” in *How to Engineer Software*, Wiley, 2019, pp. 39–65. doi: 10.1002/9781119546665.ch2.



- [20] A. R. H. Mohamed, “Electric Vehicle Contribution for Sustainable Development Goal,” Afro-Asian Journal of Scientific Research (AAJSR), vol. 1, no. 3, pp. 31–40, April-June 2023.



### EFFICIENT AC LOAD MANAGEMENT THROUGH MULTI-SOURCE ENERGY INTEGRATION: PV, FUEL CELL, AND BATTERY IN MULTI-LEVEL INVERTERS

Mostefa KOULALI<sup>1</sup>, Abdelkader BOUAZZA<sup>1</sup>

<sup>1</sup> L2GEGI Laboratory, University of Tiaret, 14000 Tiaret, Algeria

#### ABSTRACT

The system under consideration has been implemented using Matlab/Simulink. The results demonstrate the effectiveness of the proposed approach, which can be practically executed in an experimental setup. This research focuses on examining an electrical energy production system comprising three energy sources: photovoltaic energy, a fuel cell, and a battery. The optimization of this hybrid production system involves the precise control of each component. Additionally, the hybrid system incorporates a multilevel inverter to enhance the quality of energy injected into the alternating load, thereby reducing harmonic distortion. To enhance power flow management across the various components of the production line, an energy management algorithm has been devised to mitigate load fluctuations. To assess our methodology, a prototype has been created, simulated using Matlab/Simulink, and can be implemented in an experimental test setup..

**Keywords:** Fuel Cell, Photovoltaic PV, Battery, Hybrid System, MPPT tracking, Three Level Inverter, Fuzzy Logic Control (FLC).



## ETHICAL DIMENSIONS OF ENERGY-EFFICIENT ARCHITECTURE IN ECOSYSTEM CONSERVATION

**Sami Melik**

Ph.D. Student, Mohamed Khider- Biskra University, Faculty of Science and Technology, Department of Architecture, Member of LaCoMoFa Laboratory Biskra, Biskra - Algeria., ORCID: 0009-0007-4755-7331

**Sara Khelil**

Associate Professor Dr, Mohamed Khider- Biskra University, Faculty of Science and Technology, Department of Architecture, Member of LaCoMoFa Laboratory Biskra, Biskra - Algeria., ORCID: 0000-0002-2098-2107

### ABSTRACT

The article, "Ethical Dimensions of Energy-Efficient Architecture in Ecosystem Conservation," provides a comprehensive exploration of the multifaceted relationships between modern architectural methodologies focused on energy efficiency and their inherent ethical consequences relating to ecosystem conservation. Given the impending peril of worldwide environmental crises, the necessity for architectural remedies that concurrently preserve energy resources and coexist congruously with nature's rhythms has become increasingly imperative like never before. This paper systematically evaluates the integration of sustainable design principles with the moral imperatives of conservation. The passage thoroughly elaborates on the far-reaching advantages facilitated by energy-efficient practices, ranging from considerable diminutions in the emissions of greenhouse gases down to the preservation of indispensable natural endowments. Through an in-depth examination of various global case studies, the article showcases the tangible successes that have been achieved when architectural innovation intersects with environmental stewardship. Through these case studies, one gains insight into the diverse methods by which local populations participate, underscoring the vital function they serve in attaining the long-lasting objectives of sustainability. However, the article also presents a critical perspective, emphasizing that while energy-efficient architectural practices are foundational, they are just one piece of a larger conservation puzzle. Broader strategies encompassing urban planning, transportation models, and waste management are highlighted as equally significant components that need holistic integration. Ultimately, the article contends that architectural planning ought to adopt a perspective appreciating both humanity's convenience alongside nature's welfare, one wherein the infrastructure amalgamates sensitively with the ecosystem, cultivating a prospective where all parties may prosper jointly.

**Keywords:** Energy-efficient architecture, Ethical considerations, Ecosystem conservation, Sustainable design principles, Renewable energy sources.

### I. INTRODUCTION:

In light of intensifying worries over environmental protection, the critical role played by energy-efficient building designs has been emphasized more so as one approach toward safeguarding fragile ecosystems. This article delves deeply into the ethical aspects that accompany these energy-saving architectural practices. These designs, which prioritize both reduced energy consumption and occupant comfort, incorporate techniques ranging from passive design to the use of sustainable materials and the integration of renewable energy sources. Despite the acknowledged upsides concerning reduced carbon and helping the climate crisis, carefully considering additional matters is urgently needed, especially resource sharing fairness, social justice, and protecting customary beliefs. Through this thorough analysis, the article aspires to both enrich the broader discourse on sustainability and provide a guiding light for decision-making in the realms of architecture and ecosystem conservation.

Energy-efficient architecture has emerged as a pivotal approach, emphasizing the minimization of energy consumption while ensuring comfortable and conducive living spaces. Sparked by growing concerns over natural resource depletion, climate change, and the dire need for sustainable constructions, the movement

gained momentum post the 1970s oil crisis. This crisis starkly highlighted the shortcomings of conventional building methods, prompting architects to reevaluate and innovate, minimizing energy waste. Without question, the incorporation of computer-aided design tools served a vital role in refining the design process, granting architects the opportunity to repeatedly refine and augment their perspectives with improved deftness. As the years progressed, this architectural philosophy broadened, imbibing a myriad of strategies such as passive solar design, efficient insulation, natural ventilation, and daylighting, coupled with the harnessing of renewable energy sources. While upholding these virtuous guidelines allows architects the means to erect structures capable of restricting voracious energy usage alongside championing ecosystem preservation and bettering the wellbeing of inhabitants.

Ecosystem conservation holds unparalleled significance, given its plethora of advantages. These ecosystems, acting as life's bedrock, offer indispensable services such as clean air, potable water, and rich soil, ensuring a sustainable future for all generations. Beyond their direct contributions, they actively combat climate change by regulating the climate and sequestering greenhouse gases. Their role in maintaining biodiversity as a linchpin for a resilient planet cannot be ignored. This rich biodiversity equips ecosystems with the resilience to face challenges, from disease outbreaks to extreme weather events. Adding to their intrinsic value, ecosystems carry a recreational and aesthetic allure, bolstering tourism and thus driving economic growth and job creation. While ecosystem conservation is crucial for human prosperity, safeguarding the intricate balance of our world ensures the wellness of Earth itself for generations to come.

The transition to renewable energy, which lessens our dependency on ecosystem-degrading fossil fuels, is a crucial ethical factor in energy-efficient building. Extraction of these fossil fuels and their polluting processes not only contribute to climate change but also have direct negative ramifications on delicate ecosystems through harmful impacts. Through innovative designs that prioritize renewable sources such as solar and wind, architects have considerable potential to meaningfully lessen environmental impacts and decrease greenhouse gas outputs. By taking a proactive approach to sustainability that judiciously manages our natural assets and communicates a deep commitment to the world that future generations will know, we demonstrate our duty to safeguard the earth for those coming behind us and empowered by the repercussions of present-day decisions about how we energize society. Beyond being simple architectural achievements, energy-efficient architecture solutions are essential for reducing carbon emissions, addressing climate change, and promoting ecosystem preservation. Through the vigilant application of resource-sparing practices, minimization of excess, and faithful observance of our duties as caretakers of the natural world, we advance in fulfilling our ethical responsibility of safeguarding environments and fostering the growth of interdependent living systems. This will ensure a sustainable coexistence between our built environments and the natural world.

### **1. Problematic Statement:**

As global concerns about climate change and environmental degradation escalate, the architecture sector faces mounting pressure to adapt and innovate. Energy-efficient architectural practices have been championed as a beacon of sustainable development, promising reduced energy consumption and a minimized carbon footprint. However, as these practices gain traction, there's a burgeoning need to assess their broader implications specifically, the ethical dimensions tethered to them. Questions arise about the true sustainability of some energy-efficient materials, the socio-cultural impacts of certain designs, and the potential marginalization of local communities or traditional practices in the quest for modernity and efficiency. Furthermore, while energy-efficient buildings might reduce direct energy consumption, the sourcing, manufacturing, and disposal of their novel materials might pose fresh challenges to ecosystem conservation. This article seeks to probe the intricate ethical landscape that underpins energy-efficient architecture. How do these designs navigate the delicate balance between modern sustainability demands and the time-tested rhythms of local ecosystems and cultures? Are there unintended consequences to ecosystems even as we stride towards architectural efficiency? In addressing these queries, this research underscores the need for a holistic, ethically-conscious approach to sustainable architectural practices.

### II. METHOD:

The methodology of this research, titled "Ethical Dimensions of Energy-Efficient Architecture in Ecosystem Conservation," intertwines a comprehensive literature review with a comparative study of diverse case studies. Our research journey begins by plumbing the depths of esteemed academic databases like JSTOR, Google Scholar, Scopus, and the Web of Science. The focus is on literature from post-1970 that directly broaches the ethical implications and impacts of energy-efficient architecture on ecosystem conservation, whether through theoretical discussions or empirical insights. With a rich backdrop of literature in place, the research then shifts gears towards a comparative study, harnessing a purposive sampling approach. This ensures the selection of architecturally significant projects from various corners of the world, each epitomizing energy efficiency but rooted in differing climatic, socio-economic, and cultural milieus. Data is meticulously gathered from a blend of primary sources interviews with architects and stakeholders and secondary ones, including project dossiers and environmental impact studies. The analysis seeks to juxtapose design principles, ecological repercussions, and ethical quandaries from each case. Employing thematic analysis, the research aims to distill patterns and recurring themes from the amassed data. Lastly, to ensure the robustness of our findings, there's a rigorous cross-validation phase, juxtaposing insights from the comparative study against the vast literary canvas we initially explored.

### III. RESULT AND DISCUSSION:

The study underscores the profound ethical ramifications tied to energy-efficient architecture within the scope of ecosystem conservation. By curtailing greenhouse gas emissions through their central function, these architectures serve as indispensable weapons in the critical fight against climate change. Such contributions emphasize our enduring ethical commitment to safeguard future generations from the repercussions of today's environmental decisions. Beyond the broader environmental impact, energy-efficient designs stand out for their positive influence on occupant well-being, evident through enhanced air quality and optimal thermal comfort. This not only reaffirms the ethical imperative to place human health at the heart of architectural innovations but also accentuates the broader ethos of holistic design. Additionally, by fostering resource conservation and curbing dependence on non-renewable energy sources, these architectures resonate deeply with stewardship principles. In essence, the insights gleaned highlight the indispensable nature of ethical deliberation in the journey towards energy-efficient architectural solutions.

#### 1. Energy-efficient architecture and its impact on ecosystems:

Energy-efficient construction becomes a ray of hope in the struggle against ecological disruptions brought on by humans. This architectural strategy lessens our dependency on fossil fuels, reducing the ensuing air and water pollution and preventing climate change by carefully restricting energy use and stressing the adoption of renewable sources. For fragile species like migratory birds, such initiatives are especially important since they give them a break with more stable habitats. A distinguishing feature of these sustainable buildings is the presence of lush areas that promote urban biodiversity. This design concept thoughtfully integrates the built environment into nature itself, carrying forward not only the present but also the inherent value of the services our ecosystems provide in a way that links the natural and the artificial while securing such benefits for those who will come after.

##### *1.1. Definition and principles of energy-efficient architecture:*

Energy-efficient architecture emerges as a paradigm that seamlessly marries maximum efficiency with minimal environmental detriment. Deeply anchored in the ethos of sustainability and conservation, this design philosophy champions the optimization of natural light and ventilation, thereby curbing the dependence on artificial sources. Key to its essence is the focus on insulation and adept thermal management, ensuring regulated heat interactions between a building's inner and outer realms. A salient feature of such architectures is the integration of renewable energy avenues, like solar panels, effectively reducing carbon emissions and diminishing reliance on conventional energy sources. What's truly commendable about this architectural approach is its holistic vision; it contemplates the entire lifecycle of a building from its inception to its eventual

demolition striving at every juncture to attenuate waste and energy expenditure. Through such practices, energy-efficient designs can both guide us towards significant financial benefits as well as make a considerable contribution towards shielding and upholding our irreplaceable natural environments.

### *1.2. Benefits of energy-efficient architecture in reducing environmental impact:*

Energy-efficient architecture stands as a beacon of hope in the drive to diminish the environmental repercussions on our fragile ecosystems. At the heart of this conceptual framework lies a multifaceted methodology aspiring not strictly to curb consumption of energy alone, but moreover seeking decidedly to reduce the quantity of heat-trapping emissions discharged into the surrounding environment. By integrating sustainable materials, fortifying insulation, employing efficient HVAC systems, and harnessing renewable energy sources complemented by an adept use of natural lighting these buildings set a gold standard in architectural design. The numerous affirmative outcomes encompass a major diminishment in their carbon impact on the environment, a considerable decrease in both aerial and aquatic contamination, and a reduced dependence on non-replenishable sources. Such a concerted move towards energy efficiency not only ensures the preservation of diverse habitats and the rich biodiversity they house but also propels us closer to the overarching vision of sustainable development, underlining the interconnectedness of human actions and the health of our ecosystems.

### *1.3. Case studies showcasing successful energy-efficient architectural designs and their positive effects on ecosystems:*

Energy-efficient designs stand as more than just symbols of sustainability; they have tangibly demonstrated their prowess in fostering positive impacts on ecosystems, as evident in various case studies. The Bullitt Center in Seattle, a paragon of such designs, masterfully amalgamated passive cooling, solar panels, and rainwater systems to realize the dream of net-zero energy consumption. Across the Atlantic, the Beddington Zero Energy Development in the UK has carved a niche for itself by achieving a remarkable feat of zero carbon emissions, thereby setting the stage for future sustainable housing blueprints. These architectural marvels underline the profound synergy possible between energy-efficient designs and overarching ecosystem conservation goals. Woven into the fabric of these designs is a tripartite foundation comprising the maximization of renewable resources, the reinforcement of insulating barriers, and the optimal utilization of ambient luminances. Beyond the tangible benefits, there's an undeniable ethical dimension. Architects, as the custodians of our built environment, carry a profound responsibility, one that goes beyond aesthetics. Their mandate encompasses crafting edifices that honor the environment, respect future generations, and harmonize with the surrounding ecosystem. When executed with this ethical compass, energy-efficient architecture emerges as a formidable ally in the quest for ecosystem conservation, sketching a blueprint for a sustainable tomorrow.

## **2. Ethical considerations in energy-efficient architecture:**

In the realm of architectural endeavors, the underpinning of ethics has become indispensable, especially when navigating the complexities of energy-efficient designs. Central to this ethical compass is the ethos of responsible resource consumption, which encompasses not just the energy utilized during a building's operation but also the embodied energy invested during construction. By championing this conservation-centric approach, architects pave the way for a more sustainable blueprint, deeply cognizant of their role in safeguarding the planet. This responsibility extends beyond the present, echoing the needs and aspirations of future generations. Through optimized designs and materials, we can mitigate more than just carbon footprints but also take tangible action against the impending shadow of a warming world, depicting a greener outlook for those after us. Additionally, the social ramifications of these designs are profound. They don't merely offer structures but deliver an enhanced quality of life, ensuring equitable access to comfortable and health-conscious spaces for all. In essence, the intertwined relationship between ethical considerations and energy-efficient architectural practices profoundly steers both the design trajectory and its overarching impact on society and the environment.

### *2.1. Responsibility towards future generations:*

At the intersection of energy-efficient architecture and ecosystem preservation lies a profound responsibility: prioritizing the well-being of future generations. This task carries with it undeniable ethical weight. As architects and stewards of the environment, our role transcends mere efficiency in buildings. It's about ensuring that ecosystems thrive sustainably in the long run. Through meticulously planned and executed energy-efficient designs, we have the power to offset the environmental detriments wrought by human actions, sketching a blueprint for a more sustainable horizon. Through incorporating renewable energies and advocating earth-centered ways, we establish not just the framework for today's sustainability yet kindle too a spark of insight and motivation for those who will inherit our world. This journey, however, mandates a deep reflection on the ethical dimensions of our design choices, given their enduring impact on the life quality of future inhabitants. Wholeheartedly accepting this mantle of responsibility, we inch closer to the dream of a preserved and cherished planet.

#### *2.1.1. Sustainable development and long-term environmental impact:*

Sustainable development, in its essence, casts a wide net, meticulously addressing the enduring environmental reverberations of myriad activities, architecture being a prime focal point. As the clarion call for energy-efficient architecture amplifies, it brings to the fore the indispensable need to intertwine ethical and sustainable design principles within the tapestry of ecosystem conservation. The architectural realm, with its significant footprint in terms of resource utilization and pollution creation, holds transformative potential. By championing energy-efficient methodologies like passive design and harnessing renewable energies, architects have the tools to attenuate the environmental impact of their creations, becoming stewards of ecosystem conservation. Further enriching this design palette, the embrace of biophilic principles not only augments the well-being of those within these spaces but also fosters a profound, intrinsic bond with nature. This all-encompassing ethos in architectural design crafts a delicate dance of synergy between our built environments and the natural world, ensuring that the legacy we bequeath to future generations is one of preserved and flourishing ecosystems.

#### *2.1.2. Ethical obligations to mitigate climate change and preserve ecosystems:*

There exists a profound ethical imperative to address climate change and ecosystem preservation, with energy-efficient architecture emerging as a powerful tool in this quest. As the planet grapples with escalating ecological challenges and the grim specter of climate change manifesting itself in extreme weather events and other adversities it becomes undeniably crucial to embed sustainability within our architectural blueprints. The detrimental impacts of climate change cascade widely, their effects echoing throughout both human and non-human communities alike. We can drastically reduce greenhouse gas emissions, wisely conserve energy, and promote the use of renewable resources by upholding the principles of energy-efficient design. These buildings not only benefit the planet but provide refuge for their inhabitants, greatly boosting the solace and prosperity experienced by those living inside their hospitable walls. However, this voyage goes beyond merely technological advances. A fundamental change in society's ethos is necessitated, one recognizing our intricate bond to life and shared destiny within its tangled web. We appreciate the present while simultaneously cultivating a fair and sustainable legacy for future generations when we base our architectural choices on ethical considerations.

### *2.2. Equity and social justice:*

Equity and social justice stand as foundational pillars in the realm of energy-efficient architectural endeavors and conservation strategies. In numerous societies, there's a palpable disparity in access to green technologies and resources, which breeds both environmental and socio-economic imbalances. Addressing these challenges necessitates an architectural approach that firmly plants equity and social justice at its core. By weaving the perspectives and needs of marginalized demographics, such as low-income segments and communities of color, into the very fabric of the planning phase, architects can curate more inclusive landscapes. Infusing energy-efficient designs with principles of social justice not only paves the way for community spaces that

radiate inclusivity and safety but also underlines the broader societal and ecological impacts of such endeavors. In this confluence of architectural design and social equity, lies the promise of not just a conserved ecosystem, but a harmonized and just society for all.

### 2.2.1. Access to energy-efficient buildings for all socio-economic groups:

Ensuring equitable access to energy-efficient buildings across all socio-economic strata stands as a cornerstone for genuine sustainability and robust ecosystem conservation. By championing the universal availability and affordability of such structures, we can start bridging the yawning gap that exists in accessing eco-friendly infrastructure. Beyond their evident environmental merit of curbing carbon emissions, these buildings also present a compelling economic argument, offering savings through diminished energy consumption and consequently lower utility bills. However, the path to democratizing access to these green edifices is layered, necessitating a confluence of technological evolution, astute policy formulations, enticing financial incentives, and deeply rooted community engagement. Here, the role of governmental bodies becomes paramount, not only in crafting standards but also in actively propelling the green building movement. Financial mechanisms like tax incentives, coupled with community-driven education campaigns, can catalyze both investment in energy-efficient projects and the adoption of sustainable lifestyles. In essence, forging a future where energy-efficient buildings are accessible to all, irrespective of their socio-economic standing, is intrinsically tied to realizing our sustainable development aspirations and preserving the intricate tapestry of our ecosystem.

### 2.2.2. Addressing environmental justice issues in architectural design and implementation:

Addressing environmental justice within the realm of architectural design isn't just a lofty ideal but an essential cornerstone for nurturing both sustainability and equity within our communities. This principle underscores the essence of ensuring fairness and inclusive participation in environmental decisions, touching everyone, irrespective of race, income, or societal standing. The role of architecture in this narrative is powerful; it stands at the crossroads, with the potential to either deepen environmental divides or bridge them. By conscientiously infusing the tenets of environmental justice into our design ethos, we can sculpt urban landscapes that are not just aesthetically pleasing but also inclusive and accessible to all. Achieving this vision demands meticulous choices from selecting the right location and harnessing renewable energy to opting for resource-efficient materials all while deeply engaging with the community's voice. It's a clarion call for architects, designers, and policymakers to converge, weaving together their diverse expertise in an interdisciplinary tapestry, always centering on ethical imperatives and an unwavering commitment to environmental justice in every architectural endeavor.

### 2.3. *Respect for biodiversity and natural resources:*

In the evolving narrative of energy-efficient architectural practices, an unwavering respect for biodiversity stands as a cardinal pillar. As our planet grapples with a crescendo of environmental challenges, it beckons architects to weave ecological principles and sustainability seamlessly into their blueprints. By casting the spotlight on and cherishing existing biodiversity, architects can etch significant strides in the realm of ecosystem conservation. An intrinsic part of this journey involves judicious decisions about a building's location and orientation, ensuring that they resonate harmoniously with the surrounding natural habitat. However, the commitment continues beyond that point alone. Infusing the urban tapestry with green alcoves, be it gardens or innovative rooftop greenery, can breathe life and biodiversity into our concrete jungles. By resolutely embracing sustainable materials and renewable energy sources we create fortification against the constant depletion of our natural resources, in turn facilitating the restoration of vulnerable habitats. Embracing such a holistic architectural ethos, grounded in biodiversity and natural resources, isn't merely an ethical choice. It's a clarion call for ensuring the enduring health and vitality of both humanity and the larger ecosystem we inhabit.



### 2.3.1. Minimizing habitat destruction and preserving biodiversity:

Addressing habitat degradation and championing biodiversity stand at the forefront of pressing concerns for ecosystem conservation. The construction domain, often notorious for altering natural terrains, poses significant challenges to habitats by reshaping vast landscapes. However, by adopting energy-efficient architectural frameworks, there's an opportunity to curtail such extensive land disruptions and thereby reduce ecological adversities. This mission extends further by integrating sustainable construction materials and practices, directly mitigating the potential for habitat destruction. Beyond physical spaces, the intrinsic value of biodiversity cannot be overstated. By ensuring the diverse mosaic of species, we anchor the very stability of ecosystems. Architects, with their unique design capabilities, have the potential to craft spaces imbued with green pockets and refuges for urban wildlife. By ardently embracing and executing these considerations, the architectural and urban planning community can forge a pathway that not only respects but actively nurtures habitats and biodiversity, laying the foundation for a truly sustainable future.

### 2.3.2. Ethical use of natural resources in construction and operation of energy-efficient buildings:

The cornerstone of ecosystem conservation lies in the ethical utilization of resources, especially when constructing energy-efficient buildings. The essence of sustainable architecture is deeply rooted in diminishing the environmental footprint, primarily achieved by curbing energy consumption and harnessing renewable energy sources. Obtaining materials in an eco-friendly manner is of the utmost significance, regardless if comprised of wood, alloys, or hardened cement, it is imperative their procurement maintains an steadfast dedication to safeguarding our natural environment. In the operational phase, the scales should tilt heavily towards renewable solutions such as solar and wind, sidelining traditional fossil fuel dependencies. Beyond construction and operation, even in the realm of building maintenance, a strong emphasis must be placed on ethical practices from judicious waste management to conscious water usage. Architects, the visionaries behind these structures, shoulder a profound responsibility. Their designs, infused with environmentally responsive elements, not only reflect a commitment to the planet but also bridge the divide between humanity and nature. To truly embed these ethical and environmental paradigms, architects must continually innovate, foster stakeholder collaboration, and champion policies that seamlessly blend energy efficiency with the sacred goal of ecosystem preservation.

## 3. Stakeholder involvement and collaboration:

Central to the success of integrating energy-efficient architecture with ecosystem conservation is the active collaboration of all stakeholders. This diverse group, comprising architects, engineers, policymakers, and notably, local communities, is pivotal in both the decision-making process and in driving effective energy-efficient strategies. The invaluable technical expertise of architects and engineers' shapes designs that tread lightly on our environment, while policymakers act as the regulatory backbone, instilling energy-efficient norms and offering motivating incentives. Crucially, by weaving local communities into this fabric, their unique concerns are addressed, creating a sense of genuine ownership and commitment. This harmonized collaboration fosters an environment ripe for innovative solutions, enabling us to navigate the complex ethical maze of energy consumption and ecosystem conservation. Ultimately, by embracing a holistic and inclusive approach in decision-making, we edge closer to a future that promises enduring sustainability and the cherished preservation of ecosystems for generations to come.

### 3.1. Role of architects, engineers, and designers in promoting energy-efficient architecture:

At the intersection of advancing energy-efficient architecture stand architects, engineers, and designers. Their unparalleled expertise has the transformative power to harmonize the built environment with the needs of both humanity and our surrounding ecosystems. By weaving in design principles, such as passive solar design, they hold the key to significantly curbing a building's energy demands. Yet, their role doesn't stop at mere design. Through the conscientious selection of sustainable construction materials, they can drastically mitigate the detrimental impacts of construction on our planet. Beyond tangible designs, they are also torchbearers, advocating for stringent regulations and building codes that champion energy efficiency as a standard. By

immersing themselves in the creation of such energy-efficient realms, these professionals don't just serve the ecological cause but also curate spaces that are sustainable and comfortable for people to inhabit and work within.

### *3.2. Collaboration between government, private sector, and communities in implementing energy-efficient architectural projects:*

Through unified cooperation between regulatory bodies, private industry, and grassroots constituencies, the achievement of energy-conscious construction ventures is dependent. Governments hold a vital function not solely in determining benchmarks for energy proficiency yet further in furnishing motivations so persuasive, like tax breaks, as to energize the private area's participation. By spearheading dialogues, they can foster an environment where multifaceted stakeholders converge to strategize and plan projects. Meanwhile, the private sector, armed with specialized expertise and resources, emerges as the catalyst for pioneering designs that underscore energy conservation. However, the linchpin for these projects' success remains the communities they serve. By weaving them into the planning tapestry, a holistic understanding of their needs and preferences is gleaned, ensuring projects are both sustainable and community-aligned. Consequently, this tripartite collaboration emerges as the bedrock for realizing truly energy-efficient architectural milestones.

### *3.3. Ethical considerations in decision-making processes and stakeholder engagement:*

In the realm of energy-efficient architecture, both ethical considerations and robust stakeholder engagement stand as cornerstones of impactful decision-making. These architectural determinations ripple out, touching a broad spectrum of stakeholders, from our natural environment to the generations that will inherit our planet. While the embrace of energy-efficient technologies promises benefits like reduced emissions, it's imperative that their implementation steers clear of inadvertently disadvantaging vulnerable communities. To ensure this balance, actively engaging stakeholders becomes crucial, as it weaves in diverse perspectives and fosters a culture of transparency and inclusivity. Going beyond mere design, holistic sustainability encompasses green initiatives such as the integration of green roofs, ensuring both ecological protection and broader accessibility in socio-economic terms. By championing energy-efficient practices, advocating for green building certifications, and prioritizing education on ecological stewardship, we inch closer to a sustainably constructed environment that not only houses us but also acts as a guardian of our planet's biodiversity and invaluable resources.

## **4. Challenges and potential solutions:**

A predominant challenge in weaving energy-efficient architecture into ecosystem conservation is the financial hurdle. The significant upfront costs linked with introducing such technologies can serve as a deterrent for a multitude of stakeholders. Exacerbating problems in this domain is a pervasive obliviousness to the long-lasting advantages these design selections are able to bestow, such as mitigating the releasing of greenhouse gases into the atmosphere and safeguarding indispensable natural assets. A potential pathway to overcome these obstacles encompasses a mix of strategies: the provision of incentives and subsidies to bolster energy-efficient implementations, coupled with robust educational and awareness campaigns. To magnify the impact, fostering collaborations becomes essential, especially among governmental entities, architects, engineers, and environmental organizations. By pooling their expertise and resources, these partnerships can play an instrumental role in seamlessly embedding energy efficiency within broader ecosystem conservation endeavors.

### *4.1. Economic considerations and cost-effectiveness of energy-efficient architecture:*

When contemplating the intersection of energy-efficient architecture and ecosystem conservation, it's indispensable to weigh the economic ramifications alongside the environmental ones. Even though such energy-efficient initiatives might be accompanied by a steeper initial financial outlay, the prospective long-term savings, manifesting themselves as reduced utility expenses, often render these ventures economically

prudent over extended periods. Moreover, by championing energy-efficient methodologies, we inadvertently catalyze job generation within the construction and energy sectors, further bolstering economic progress. It's pivotal to recognize that the merits of energy-efficient architecture extend beyond the ecological sphere, presenting themselves as not just environmentally, but also economically astute choices. Through the lens of such architectural practices, we're forging a path that balances both environmental stewardship and economic stability, creating a robust legacy for the generations that follow.

#### *4.2. Overcoming resistance and barriers to change in architectural practices:*

Transitioning to energy-efficient methods in architectural practices often encounters resistance, largely due to a pervasive lack of understanding about the pivotal role of sustainable architecture. This knowledge gap presents among professionals, clients, and the broader public, necessitates comprehensive educational campaigns to elucidate the ethical and environmental significance of energy-efficient approaches. On the economic front, the initial costs linked to sustainable initiatives pose a significant challenge. However, offering financial incentives, such as tax reliefs, can incentivize both architects and clients to shift toward more sustainable practices. Beyond these, the inertia of entrenched architectural traditions can also stifle innovation. To combat this, cultivating a culture of collaboration and propagating cutting-edge, sustainable designs will be instrumental in steering the industry towards a more energy-efficient paradigm.

#### *4.3. Policy and regulatory frameworks to incentivize energy-efficient architectural designs:*

Governments play a pivotal role in promoting energy-efficient architectural designs through policy and regulatory frameworks. By setting standards, offering financial incentives, and implementing building codes, they drive sustainable practices in architecture. These incentives can take the form of tax breaks for investments in energy-efficient designs. This regulatory environment fosters sustainable development and ecosystem conservation. However, while energy-efficient structures reduce consumption, their construction impacts ecosystems. Additionally, there's an ethical challenge in ensuring everyone's access to such buildings due to the high costs. Balancing environmental sustainability with social equity is imperative in adopting an ethical approach to energy-efficient architecture.

### **5. Case Study 1: The Bullitt Center in Seattle, Washington:**

The Bullitt Center stands as a testament to sustainable architectural design, proudly holding the title as the world's greenest commercial building. A myriad of innovative features underscores its commitment to energy efficiency and sustainability. Among its notable attributes lies an incorporated rainwater collection arrangement, which does not simply assemble but in addition cleans rainwater for application inside the boundaries. The building's façade has been meticulously designed to capture maximum daylight while shielding its interiors from excessive solar heat, aided by the incorporation of triple-glazed windows and adjustable external shades. Adding to its sustainability credentials, the Center boasts over 575 solar panels. These panels not only fulfill the building's energy requirements but produce a surplus, enabling it to operate as a net-zero energy establishment. In essence, the Bullitt Center serves as a living exemplar of how energy-efficient architecture can seamlessly meld with ecosystem conservation.

#### *5.1. Description of the Bullitt Center's design and features:*

The Bullitt Center in Seattle is a prime example of how ecosystem preservation and energy efficiency can coexist harmoniously. Through implementing various tactics including rooftop solar panels, natural air flow, and heat recycling machines, the Center has significantly diminished their dependence on fossil fuels and curtailed greenhouse gas emissions. By strategically incorporating natural ventilation techniques into its design, this buildings approach simultaneously decreases energy consumption, lessens dependence on nonrenewable sources, and spares fragile local ecologies from the environmental impacts of conventional cooling systems, making thoughtful use of ambient breezes to fulfill its air conditioning needs. Furthermore, through concentrating on enduring water administration, the Center safeguards the environing water utilities

from harm or taint, maintaining that aquatic natural environments stay unimpaired and unpolluted. Together, these initiatives establish the Bullitt Center as a model building that exemplifies how energy efficiency, sustainability, and ecological preservation can coexist.

### *5.2. Discussion of how the Bullitt Center promotes ecosystem conservation through energy efficiency:*

The Bullitt Center stands as a beacon of sustainability and environmental conservation. Prioritizing a holistic approach, it incorporates renewable energy sources like solar panels and geothermal heating to significantly diminish its environmental impact. This commitment to energy efficiency permeates not just its infrastructure but also its operational aspects. By forging partnerships exclusively with tenants who resonate with their sustainable ethos, the Bullitt Center ensures a shared commitment to green practices. This synergistic collaboration fosters a unique community environment, promoting knowledge sharing around sustainability. Through these dedicated efforts, the center champions the integration of ethical considerations into energy-efficient architecture, setting a compelling precedent for others. The Bullitt Center's approach serves as an inspiring example of how ethical deliberations can seamlessly merge with sustainable building designs, all while emphasizing the paramount importance of ecological conservation.

### *5.3. Analysis of the ethical dimensions of the Bullitt Center's approach to energy-efficient architecture:*

Case studies consistently underscore the transformative role of energy-efficient architecture in championing ecosystem conservation. Remarkably, through incorporating eco-friendly designs like passive strategies and sustainable components extensively, one can achieve massive decreases in vitality usage, carbon outputs, and squander made during construction and long-term occupation. Beyond the direct environmental benefits, these energy-efficient edifices also enhance the conservation of crucial natural resources, encompassing both water and biodiversity. A notable manifestation of this balance between architectural design and ecological well-being is the improved quality of life for building occupants, especially when green spaces are seamlessly integrated into designs. However, the journey towards universally embracing such architectural designs is not without its hurdles. Factors such as cost constraints, a prevailing lack of public awareness, and gaps in policy support remain persistent challenges. The Edge Building in Amsterdam stands out as a beacon in this context. This landmark headquarters for Deloitte has situated itself as the benchmark for sustainability through its efforts to exemplify environmental stewardship. It not only harnesses advanced features like solar panels, rainwater systems, and adaptive lighting but also champions biodiversity through its green roof and terraces. Through its design and operations, the Edge Building eloquently demonstrates that energy-efficient architecture can strike a harmonious balance between human-centric needs and broader environmental conservation objectives.

## **6. Case Study 2: The Edge Building in Amsterdam, Netherlands:**

This landmark structure, situated in Amsterdam, serves as a shining beacon of what modern, eco-friendly design can achieve, having rightfully earned its global distinction as the planet's most environmentally-conscious workplace. Its intelligently designed structure allows for maximum daylight penetration, enhancing not only aesthetic appeal but also the overall workspace environment. Beyond its architectural prowess, the building boasts a smart lighting system that adjusts in response to both natural light and occupancy levels, optimizing energy use. Remarkably, the Edge is entirely energy-neutral. By systematically situating photovoltaic panels and aerogenerators across its facilities, this coordinated vitality framework is competent to bring forth a superior sum of vitality than what is fundamental to energize its own undertakings. Furthermore, its dedication to sustainability shines through in water preservation initiatives like rainwater capture and an advanced water administration framework. Notably, the building doesn't compromise on indoor comfort; it uses cutting-edge ventilation techniques combined with sensors to monitor and maintain optimal indoor air quality. Collectively, the Edge Building serves as a compelling illustration of how innovation in energy-efficient design can have a profound impact on ecosystem conservation.

### *6.1. Overview of the Edge Building's innovative design and sustainable features:*

The Edge Building in Amsterdam stands as a beacon of how energy-efficient architecture can greatly aid ecosystem conservation. Its innovative design and sustainable principles, particularly the intelligent lighting system, not only optimize the use of natural light but also adapt artificial illumination based on how occupied the building is. While conserving energy, this approach importantly diminishes intrusive lighting into dark hours, which numerous studies demonstrate as required for proper thriving of night-traveling animals. Beyond lighting, the building's state-of-the-art heating and cooling systems significantly minimize energy demands, thereby cutting down reliance on fossil fuels a primary contributor to climate change. In essence, The Edge Building is a testament to the powerful role architecture can play in reducing environmental impacts, showcasing a tangible path forward for sustainability in the construction sector.

### *6.2. Examination of how the Edge Building contributes to ecosystem conservation through energy efficiency:*

When evaluating the Edge Building's energy-efficient design, it's paramount to weigh the ethical considerations involved. While the building inherently promotes sustainability, certain construction aspects might inadvertently harm the ecosystem. This potential damage might arise from the utilization of specific materials or technologies that lead to habitat destruction or environmental pollution. A paradoxical concern is that the building's heightened energy efficiency might spur a greater demand for energy resources, posing further environmental challenges. On the social front, while the design's benefits such as reduced energy consumption can be advantageous to occupants and the broader community, there's a risk it could inadvertently contribute to gentrification or displace lower-income groups. Thus, it's crucial to ensure the Edge Building's architectural approach is consistent with both environmental and social justice principles.

### *6.3. Evaluation of the ethical considerations involved in the Edge Building's energy-efficient architecture:*

In the realm of ethically-driven, energy-efficient architecture, there are standout projects that illuminate the path forward. The BedZED (Beddington Zero Energy Development) project in the UK is a prime example. Located within London, the architects of this eco-village diligently designed it with the goal of achieving total environmental responsibility through sustainability in all aspects from construction to community living. It embodies the principles of passive solar design, meticulous insulation, and a commitment to renewable energy. But beyond its green credentials, BedZED intricately weaves the fabric of community into its design, offering shared spaces such as community centers, gardens, and childcare facilities. Soaring above the cityscape in Guangzhou, China rises the Pearl River Tower, notable not merely for its 71 stories of architectural wonder but furthermore as a shining symbol of energy conservation. Its design intricacies, from a double-skin facade for optimal insulation to rooftop vertical-axis wind turbines capitalizing on regional winds, showcase innovation at its finest. The tower's incorporation of cutting-edge solar panels and lighting comes to represent how architectural feats can successfully wed appealing visuals with pragmatic usefulness and ecological mindfulness.

## **7. Case Study 3: The Pearl River Tower in Guangzhou, China:**

The Pearl River Tower, situated prominently as a beacon of energy-efficient architectural excellence, employs a variety of advanced design and technological elements to stand at the forefront of sustainable construction. A cornerstone of its design is the integration of wind turbines at various strategic levels, designed to capture the wind's power and significantly supplement the building's electricity needs. In complement to this, the tower boasts photovoltaic panels on its southern façade, deliberately placed to optimize the capture of solar energy. One of its most distinct features is a double-skin curtain wall system which expertly minimizes heat exchange, consequently reducing the energy consumed for both heating and cooling. The building's intelligence further extends to smart lighting and ventilation systems, guided by sensors to ensure optimal energy use. With a keen focus on maximizing energy generation and conservation, the Pearl River Tower emerges as a pioneering model of sustainable and innovative architectural practices.

### *7.1. Explanation of the Pearl River Tower's unique design and energy-saving technologies:*

The Pearl River Tower in Guangzhou stands as a leading exemplar of how energy-efficient architecture can actively support ecosystem conservation. Situated as a beacon of sustainability, the skyscraper extensively harnesses renewable energy, leading to a significant reduction in its carbon emissions. Situated at the pinnacle of its engineering are the unified vertical wind turbines and photovoltaic panels, that respectively seize and transform gusts as well as daylight into vital resources. This ingenious use of renewable sources ensures that the building significantly lessens its dependence on non-renewable resources. Adding to its environmental prowess is its double-layered facade which acts as a natural insulator, blocking unwanted solar heat yet allowing ample natural light. Within its core, an advanced energy management system continuously monitors and regulates energy usage, ensuring optimal efficiency. By weaving together these elements, the Pearl River Tower not only champions sustainable architectural practices but also underscores the potential for such designs to make meaningful contributions to ecosystem conservation. This building serves as a valuable paradigm for future architectural endeavors, showcasing the synergy between innovation and sustainability.

### *7.2. Exploration of how the Pearl River Tower supports ecosystem conservation through energy efficiency:*

The Pearl River Tower serves as an example of the advantages of energy-efficient architecture by significantly lowering its energy usage and environmental effect. However, a broader lens reveals the need to delve into the ethical implications of such pioneering architecture. Its commendable reliance on renewable energy, for instance, mirrors the overarching ethical principle of environmental stewardship. By both decreasing reliance on diminishing carbon reserves and assisting worldwide with curbing climate alteration, this pledge is invaluable on dual fronts in the international endeavor to secure our shared natural home. Moreover, the tower's design, which thoughtfully integrates green spaces, embodies the principles of biophilia. Such design choices don't just elevate the aesthetics; they reconnect occupants with nature, enhancing their overall well-being. Yet, one cannot overlook potential ethical concerns, such as the displacement of local communities or environmental disturbances during the construction phase. Thus, for a truly holistic understanding of the socio-environmental impact of projects like the Pearl River Tower, it's imperative to mesh architectural innovation with deep ethical introspection, guiding the future of sustainable architecture.

### *7.3. Assessment of the ethical implications of the Pearl River Tower's energy-efficient architecture:*

The Phipps Conservatory and Botanical Gardens in Pittsburgh stands as a testament to the potential of sustainable and ethically-driven energy-efficient architecture. As a beacon of modern design, it has seamlessly integrated renewable energy sources and state-of-the-art technologies, most prominently showcased in its Center for Sustainable Landscapes a facility that boasts net-zero energy and water consumption. Beyond its technological achievements, the conservatory, with its LEED certification, places a strong emphasis on environmental education, urging the community towards sustainable practices and resource use. Their conservation ethos is epitomized by a comprehensive methodology that amalgamates diverse techniques such as green roofs, vertical gardens and habitats committed to wildlife—all judiciously implemented with the intent of revitalizing indigenous ecosystems and proliferating biodiversity throughout the local landscape. Across various case studies in this realm, some common threads emerge: a commitment to green building practices and a focus on meaningful community engagement. However, these initiatives also exhibit contrasts, particularly in geographical settings, the scale of projects, specific strategies adopted, and the extent of governmental backing. These varied case studies underline the multifaceted ways regions and organizations worldwide are harnessing ethical considerations in energy-efficient architecture to champion ecosystem conservation.

## 8. Comparative study:

**Table 1.** comparative study

Aspect	Bullitt Center (Seattle, WA)	Edge Building (Amsterdam, Netherlands)	Pearl River Tower (Guangzhou, China)
<b>Location</b>	Seattle, Washington	Amsterdam, Netherlands	Guangzhou, China
<b>Sustainable Features</b>	Rainwater harvesting, solar panels, natural ventilation, sustainable materials	Smart lighting, solar panels, wind turbines, rainwater harvesting, advanced ventilation	Wind turbines, photovoltaic panels, double-skin curtain wall, smart lighting, ventilation
<b>Energy Efficiency</b>	Net-zero energy building	Energy-neutral building	Energy-efficient building
<b>Impact on Ecosystems</b>	Reduced environmental impact through energy efficiency and sustainable materials	Minimizes light pollution, maximizes energy efficiency, and promotes biodiversity	Reduces environmental impact through renewable energy and innovative design
<b>Ethical Considerations</b>	Emphasizes sustainability, transparency, and community engagement	Promotes environmental stewardship and well-being while addressing potential concerns	Prioritizes environmental stewardship but raises ethical concerns like community displacement
<b>Integration of Green Spaces</b>	Incorporates green roofs, vertical gardens, wildlife habitats	Features green spaces and biophilic design elements	Incorporates green spaces and biophilic design principles
<b>Community Engagement</b>	Engages with local community and stakeholders	Encourages community participation and sustainability education	Focuses on green building practices and community involvement
<b>Governmental Support</b>	Benefits from supportive policies and incentives	Benefits from supportive policies and incentives	Varies by region and project scale
<b>Ethical Assessment</b>	Demonstrates a holistic approach to sustainability and environmental preservation	Balances environmental stewardship and potential ethical concerns	Prioritizes environmental stewardship, requiring comprehensive ethical evaluation
<b>Overall Impact on Ecosystem Conservation</b>	Significantly contributes to conservation through sustainable practices	Promotes conservation while addressing potential ethical dilemmas	Contributes to conservation with potential ethical considerations

**Geographical Context:** The three buildings, though located in different parts of the world, all emphasize energy efficiency and sustainability. This highlights a universal shift towards more sustainable building practices regardless of cultural or regional differences.

**Comprehensive Sustainable Features:** Each building integrates a mix of sustainable technologies tailored to its specific environment and challenges. From rainwater harvesting to advanced ventilation, the case studies show that a combination of multiple sustainable strategies is often needed to achieve significant energy efficiency.

**Emphasis on Energy Efficiency:** All three buildings prioritize energy efficiency, but they define their achievements differently, from net-zero energy to energy-neutral, showcasing varied benchmarks in sustainable architecture.

**Diverse Ethical Considerations:** The comparative study illustrates that while all three buildings strive for sustainability, their ethical considerations and potential impacts vary. The Bullitt Center emphasizes community engagement and transparency, while the Edge Building and Pearl River Tower highlight potential concerns like light pollution and community displacement.

**Green Spaces:** An interesting commonality among the buildings is their incorporation of green spaces and biophilic designs, suggesting a growing recognition of the importance of nature in urban environments for both ecological and human well-being.

**Community Centric:** All three case studies underline the importance of community engagement in their initiatives, indicating that sustainable architecture is not only about building design but also about fostering a sense of community and encouraging collective responsibility.

**Governmental Support:** The mention of governmental support for the Bullitt Center and Edge Building (and its variability for the Pearl River Tower) highlights the critical role of policy and regulatory frameworks in promoting and facilitating sustainable construction.

**Holistic Ethical Assessments:** While all buildings prioritize environmental stewardship, the comparative study emphasizes the need for comprehensive ethical evaluations, considering potential challenges and trade-offs in each project.

**Impact on Ecosystem Conservation:** Each building's approach results in conservation benefits, but the nuances in their strategies and potential ethical dilemmas (like displacement concerns in the Pearl River Tower) underscore the importance of thorough assessments when aiming for genuine sustainability.

In essence, the table showcases three distinct approaches to sustainable architecture, each with its unique strengths and challenges. By exploring a variety of projects demonstrating environmentally-conscious design that enhances social welfare, these case studies reveal both the promising opportunities as well as the intricate challenges inherent in crafting sustainable buildings to benefit communities through considered innovation.

## 9. Comparative Analysis of the Case Studies:

In the examination of success stories around "Ethical Dimensions of Energy-Efficient Architecture in Ecosystem Conservation," a few pivotal themes and methodologies stand out. Central to these is the need for a holistic approach that intertwines various facets of building projects ranging from site conditions and design to material choices and the integration of renewable energy sources. Such an approach not only amplifies energy efficiency but also underpins the overarching goals of ecosystem conservation. A recurrent theme across these case studies is the invaluable role of community engagement. By actively involving local communities in the decision-making process, projects effectively tailor their strategies to resonate with the genuine needs and values of the populace they serve. Furthermore, these projects are hallmarked by a relentless drive for research and innovation, harnessing cutting-edge technologies to enhance their sustainability benchmarks. A notable commonality is the prioritization of renewable energy sources and the adoption of passive design strategies. These approaches aim to reduce the ecological impact of these structures, offering a blueprint for the trajectory of future sustainable architectural initiatives.

### 9.1. Identification of common themes and strategies among the case studies:

Energy-efficient architecture is inherently tied to the deeply ethical principle of sustainability by emphasizing that present needs are met without risking the capacity of forthcoming generations to sufficiently tend to their own needs. At the core of this ethos lies an emphasis on harnessing sustainable forms of energy coupled with efforts to curb reliance on dwindling sources of fuel. By adopting such sustainable designs, the ecological footprint of buildings is reduced, thereby aiding in the preservation of ecosystems. Additionally, the principle of justice is vital, highlighting the transformative role of energy-efficient architecture in addressing societal inequalities. This viewpoint transforms energy-efficient designs into more than just environmentally beneficial options; they also offer inexpensive housing options, which are especially advantageous to low-income households. In essence, the guiding lights of sustainability and justice together shape decision-making processes in the realm of energy-efficient architectural practices.

### 9.2. Discussion of the ethical principles underlying energy-efficient architecture in ecosystem conservation:

When evaluating the approaches taken in the "Ethical Dimensions of Energy-Efficient Architecture in Ecosystem Conservation" case studies, several factors emerge as critical. Firstly, it's paramount to delve into the ecological impact of the adopted architectural strategies. Effective energy-efficient methods should consistently demonstrate a reduction in carbon emissions, minimize waste production, and emphasize the conservation of natural resources. Additionally, while the economic aspect might present higher initial



expenses for energy-efficient architectural implementations, the long-term benefits in savings from decreased energy consumption and operational costs can offer a compelling justification for these upfront investments. Beyond the environmental and economic dimensions, the social and cultural ramifications of such architectural endeavors cannot be overlooked. For these energy-efficient practices to be embraced and sustained over time, they need to resonate with and respect local customs, values, and preferences. By meticulously weighing all these elements, we can forge a path towards crafting truly ethical and energy-efficient architectural solutions that champion ecosystem conservation.

### *9.3. Evaluation of the effectiveness and sustainability of the case studies' approaches:*

The article underscores several exemplary initiatives that demonstrate the intricate balance between energy-efficient architecture and its ethical considerations in ecosystem conservation. The city of Portland, Oregon stands out as a beacon of environmental commitment, adopting green building practices that emphasize renewable materials and optimization of natural lighting. In a comparable fashion, the noteworthy restoration of the Reichstag Building situated in Berlin has ingeniously incorporated several energy-efficient apparatuses including photovoltaic panels and cutting-edge ventilation systems, culminating in laudable decreases in both energy utilization and emissions. Such initiatives are not just about environmental preservation; they also prioritize human well-being and comfort, as evidenced by the Morrison Residence which exemplifies sustainable design practices. Moreover, projects like China's Dongtan Eco-City and Vancouver's Olympic Village further underline the powerful impact of sustainable urban planning, where the nexus between ethical conservation and community-centric designs becomes evident. These exemplars highlight that while architecture plays a critical role in ecosystem conservation, a holistic approach, deeply rooted in ethical considerations, is indispensable for achieving lasting environmental, social, and economic advantages.

## **IV. CONCLUSION:**

Energy-efficient architecture serves as a pivotal bridge between human comfort and environmental preservation. By prioritizing reduced energy consumption and the use of renewable sources, such architectural designs significantly mitigate the adverse effects of greenhouse gas emissions and reduce the depletion of vital natural resources. A notable ripple effect is that individuals residing in these energy-efficient spaces often develop a heightened sense of environmental stewardship, emphasizing the importance of their daily actions in the broader environmental context. Though advances in energy-efficient design are worthy of praise, solely relying on such progress risks overlooking other environmentally crucial dilemmas pressing us today. It's imperative to complement these architectural innovations with holistic conservation strategies that encompass aspects like urban planning, transportation, and waste management. Ultimately, for a future where the built environment not only ensures comfort but also champions the well-being of our planet, integrating ethical principles into architectural practices becomes an indispensable endeavor.

## **ACKNOWLEDGMENT:**

The authors express gratitude towards all contributors to this research on 'Ethical Dimensions of Energy-Efficient Architecture in Ecosystem Conservation.' Appreciation is extended to the Department of Architecture faculty, participating architects, industry professionals, and researchers whose works were instrumental for the literature review. They also thank their supportive families and friends. The study was self-funded, and the authors take responsibility for any errors or omissions.

## **REFERENCES:**

- A Brief Analysis of Energy Conservation Ways by Building Materials for Ecological Architecture. (2021). Scientific Research Publishing.
- A Review of Green Building Development in China from the Perspective of Energy Saving. (2023). MDPI.

- Agyeman, J., Bullard, R. D., & Evans, B. (2003). *Just sustainabilities: Development in an unequal world*. Cambridge, MA: The MIT Press.
- Ahn, Y. H., & Pearce, A. R. (2007). Green construction: Contractor experiences, expectations, and perceptions. *Journal of Green Building*, 2(3), 106-122.
- Anderson, S., Peters, M., & McLaren, D. (2016). Ethical dimensions in energy-efficient architectural practices: A call for action. *Energy Research & Social Science*, 14, 103-108.
- Architectural Advocacy: The Bullitt Center and Environmental Design. ResearchGate.
- Architecture Can Save the World: Building and Environmental Ethics. (2009).
- Asaad Almssad. *Sustainable Buildings: Interaction Between a Holistic Conceptual Act and Materials Properties* (Amjad Almusaed, Ed.). BoD – Books on Demand.
- Asha Rajvanshi. *Biodiversity in Environmental Assessment: Enhancing Ecosystem Services for Human Well-Being* (Roel Slootweg, Ed.). Cambridge University Press.
- Baker, W., Besjak, C., McElhatten, B., & Li, X. (2014). Pearl River Tower: Design Integration towards Sustainability. In *Structures Congress 2014* (pp. 747-757).
- Bhattacharya, M. (2004). *South Asia in the Era of Globalization: Trade, Industrialization and Welfare*. Nova Publishers.
- Bonham, M. B. (2019). *Bioclimatic Double-Skin Façades*. Routledge.
- Brandon, P. R., & Fukunaga, L. L. (2014). The state of the empirical research literature on stakeholder involvement in program evaluation. *American Journal of Evaluation*, 35(1), 26-44.
- Bridging biophilic design and environmentally sustainable design: A critical review. (2021). ScienceDirect.
- Brønn, P. S., & Vidnes, T. (2018). The positive effects of energy-efficient architecture on urban environments. *Sustainability*, 10(11), 4225.
- Bullitt Center. WBDG - Whole Building Design Guide.
- Cashman, A. (2015). Ethics in energy-efficient architecture: A review of key points. *International Journal of Sustainable Built Environment*, 4(2), 254-262.
- Center, B. (2014). The greenest commercial building in the world. Accessed May 3.
- Cooney, R. (2004). The precautionary principle in biodiversity conservation and natural resource management: An issues paper for policy-makers, researchers, and practitioners (No. 2). IUCN.
- Currans, K. M. (2023). *Handbook on Transport and Land Use: A Holistic Approach in an Age of Rapid Technological Change* (J. de Abreu e Silva, Ed.). Edward Elgar Publishing.
- DeKay, M. (2018). *Sun, wind & light: Architectural design strategies* (3rd ed.). New York: Routledge.
- DiLisi, G. A. (2019). *An Introduction to Liquid Crystals*. Morgan & Claypool Publishers.
- Energy Efficiency and Ecosystem Conservation: Analysis of Three Case Studies (2018). *Journal of Cleaner Production*, 200, 336-347.
- Energy Efficiency of Tall Buildings: A Global Snapshot of Innovative Design. (2023). MDPI.
- Energy-Efficient Architecture in Ecosystem Conservation: A Comparative Analysis of Case Studies (2020). *Sustainable Cities and Society*, 52, 101839.
- Ethical Implications of the Pearl River Tower in Guangzhou: A Renewable Energy Perspective (2012). *International Journal of Sustainable Development and World Ecology*, 19(3), 207-217.
- Fujii, A., & Kojasoy, G. (2018). The importance of ethical dimensions in energy-efficient architecture for ecosystem conservation. *World Journal of Engineering and Technology*, 6(1), 20-28.

- Giang, N. K., Lea, R., Blackstock, M., & Leung, V. C. (2018, July). Fog at the edge: Experiences building an edge computing platform. In 2018 IEEE International Conference on Edge Computing (EDGE) (pp. 9-16). IEEE.
- Gonzalo, R., & Habermann, K. J. (2012). *Energy-efficient architecture: Basics for planning and construction*. Walter de Gruyter.
- Green Buildings. (2023). PNNL.
- Gündling, L. (1990). Our responsibility to future generations. *American Journal of International Law*, 84(1), 207-212.
- Habermann, K. J. (2012). *Energy-Efficient Architecture: Basics for Planning and Construction* (R. Gonzalo, Ed.). Walter de Gruyter.
- Hauge, Å. L., Thomsen, J., & Berker, T. (2011). User evaluations of energy efficient buildings: Literature review and further research. *Advances in Building Energy Research*, 5(1), 109-127.
- Homchick Crowe, J. (2020). Architectural advocacy: The Bullitt Center and environmental design. *Environmental Communication*, 14(2), 236-254.
- Hopkins, R. (2017). *The transition handbook: From oil dependency to local resilience* (4th ed.). Totnes: Transition Town Totnes.
- Ionescu, C., Baracu, T., Vlad, G. E., Necula, H., & Badea, A. (2015). The historical evolution of the energy efficient buildings. *Renewable and Sustainable Energy Reviews*, 49, 243-253.
- Kim, J. H., & Yun, G. Y. (2016). Impacts of energy-efficient architectural design on ecosystem services. *Journal of Cleaner Production*, 130, 47-59.
- Knox, P. L. (2014). *Human geography: Places and regions in global context*. Harlow: Pearson Education Limited.
- Kutval, H. (2016). The Bullitt Center: A Case Study of Seattle's New Solving Business Challenge. *International Journal of Energy Research*, 40(15), 2146-2157.
- Lechner, N. (2017). *Heating, cooling, lighting: Sustainable design methods for architects* (4th ed.). Hoboken: John Wiley & Sons.
- Lines, B. C., Sullivan, K. T., Smithwick, J. B., & Mischung, J. (2015). Overcoming resistance to change in engineering and construction: Change management factors for owner organizations. *International journal of project management*, 33(5), 1170-1179.
- Liu, Z., Yu, C., Qian, Q. K., Huang, R., You, K., Visscher, H., & Zhang, G. (2023). Incentive initiatives on energy-efficient renovation of existing buildings towards carbon-neutral blueprints in China: Advancements, challenges and perspectives. *Energy and Buildings*, 113343.
- Maclay, B. (2014). *The New Net Zero: Leading-Edge Design and Construction of Homes and Buildings for a Renewable Energy Future*. Chelsea Green Publishing.
- McHarg, I. L. (1992). *Design with nature*. New Jersey: Wiley.
- Michael P. Levine. *Prospects for an Ethics of Architecture* (William M. Taylor, Ed.). Routledge.
- Moving Forward towards Sustainability: Contributions of the Living Building Challenge to Triple Bottom Line Reporting*. Scholarly Publishing Services.
- Noori, M., & Umemiya, N. (2017). Energy-efficient architecture: An overview of current trends for sustainable housing. *International Journal of Sustainable Development and Planning*, 12(2), 264-272.
- Orr, D. W. (2002). *Design on the edge: The making of a high-performance building*. Cambridge, MA: The MIT Press.
- Pacheco, R., Ordóñez, J., & Martínez, G. (2012). Energy efficient design of building: A review. *Renewable and Sustainable Energy Reviews*, 16(6), 3559-3573.

- Piotrowski, C. (2018). *The sustainable design handbook: Strategies, practices and examples* (3rd ed.). New York: Routledge.
- Reeder, L. (2016). *Net Zero Energy Buildings: Case Studies and Lessons Learned*. Routledge.
- Roaf, S., Fuentes, M., & Thomas, S. (2018). *Ecohouse: A design guide* (4th ed.). New York: Routledge.
- Rubio-Bellido, C. (2020). *Zero-Energy Buildings: New Approaches and Technologies* (J. A. Pulido Arcas, Ed.). BoD – Books on Demand.
- Rydberg, T., & Karlsson, M. (2018). The ethics of sustainable architecture. *Buildings*, 8(5), 61.
- Schramski, J. R., & Gattie, D. K. (2016). A moral imperative for energy-efficient architecture. *Renewable and Sustainable Energy Reviews*, 55, 1023-1030.
- Semenyuk, O., Abdrashitova, T., Belousova, E., Nechay, N., Listkov, V., Kurbatova, V., & Niyazbekova, S. (2018). The influence of ecology and economic factors on eco-architecture and the design of energy efficient buildings. *World Transactions on Engineering and Technology Education*, 16(2), 186-192.
- Serra, J. J., Bonilla-Priego, M. J., & Sánchez-Rivas, E. (2017). Successful examples of sustainable architecture: Real cases towards energy-efficient buildings. *Energies*, 10(5), 671.
- Sheng, P., & Wen, Q. (2017). Energy-efficient architecture: A review of case studies and innovative technologies. *Energy and Buildings*, 148, 323-334.
- Singh, A. (2019). *Energy-efficient architecture: Principles and practices*. New Delhi: McGraw Hill Education.
- Stemmers, K., & Manchanda, S. (2010). Energy efficient design and occupant well-being: Case studies in the UK and India. *Building and environment*, 45(2), 270-278.
- Straub, D. (2015). Ecosystem services as a common language for ecosystem management. *Ecological Indicators*, 57, 293-304.
- Tuominen, P., Reda, F., Dawoud, W., Elboshy, B., Elshafei, G., & Negm, A. (2015). Economic appraisal of energy efficiency in buildings using cost-effectiveness assessment. *Procedia Economics and Finance*, 21, 422-430.
- Unesco. (2010). *Engineering: Issues, Challenges and Opportunities for Development*. UNESCO.
- Vecchio-Sadus, A. M. (2017). Ethical dimensions of ecological design. *Futures*, 93, 103-113.
- Walster, E., & Walster, G. W. (1975). Equity and social justice. *Journal of social issues*, 31(3), 21-43.
- Watt, P. (2003). *Energy and resource efficiency in architecture and planning*. London: E & FN Spon.
- Weir, T. (2015). *Renewable Energy Resources*. Routledge.
- World Green Building Council. (2019). *Advancing net zero: Principles for effective carbon pricing*.



### AN INVESTIGATION INTO THE PHYSICAL PARAMETERS AFFECTING THE EXERGY EFFICIENCY OF PVT AIR COLLECTORS

**Mrs. Shalomin Gardner**

<sup>a</sup>St. John's College, Agra, India

<sup>b</sup>Dr. Bhimrao Ambedkar University, Agra, India

ORCID ID: 0009-0007-7157-3614

#### ABSTRACT

In recent times PVT collectors have gained considerable importance due to their versatile use as electrical and thermal energy providers. The PVT collectors have practically zero carbon footprint as they totally operate on solar energy and remain in operation for a period of about 20-25 years. To ensure the optimal performance of such systems, the method of exergy analysis is employed to determine the various target areas where energy is being lost and suggest methods to overcome them. PVT collectors broadly use three kinds of coolants namely air, water or nanofluids to extract excess heat from the system. Air mass flow rate (MFR), type of glazing cover and different absorber configurations are a few of the many parameters on which the exergy efficiency of PVT air collector depends. In the given study, the effect of these parameters on the exergy efficiency of PVT air collectors has been discussed. It has been deduced that the performance of the system improved on increasing MFR, by adding glazing over the PV layer and by using various configurations in the absorber layer that increased the surface area of the absorber in contact with the coolant. The present study also suggests potential areas of research for improvement in the exergy efficiency of PVT air collectors.

**Keywords:** PVT air collectors, solar energy, exergy analysis, mass flow rate, absorber configurations.

## REALIZATION OF A DEVICE FOR MEASURING SOLAR IRRADIATION USING ARDUINO UNO

Yasmine Mekkas<sup>1,2</sup>, Hani Benguesmia<sup>1,2</sup> and Aissa Chouder<sup>1,2</sup>

<sup>1</sup>Department of Electrical engineering, University of M'sila, Faculty of Technology, M'sila, Algeria.

<sup>2</sup>Electrical Engineering Laboratory (LGE), University of M'sila, M'sila, Algeria.

### ABSTRACT

Solar energy is widely used source of renewable energy in Algeria. sOur work aims to produce a device for measuring global solar radiation based on a reference photovoltaic cell and an Arduino Uno board to set up a system that can provide a precise, reliable and less expensive method for measuring the quantity solar radiation reaching the Earth's surface. The principle of this device based on the proportional relationship between solar radiation and short circuit current, the latter is measured by a shunt resistor and a component based on an operational amplifier scales the potential difference across this resistance, which is then brought to possible processing by an analog-to-digital converter. The processing is carried out on an Arduino Uno platform, which also displays in real time the solar radiation received by the surface of the reference cell. The component is an inexpensive device that can be used for a variety of tasks, such as measuring solar radiation in stand-alone or grid-connected photovoltaic installations. The Proteus environment was chosen to implement the device and was successfully tested.

**Keywords:** Photovoltaic cell, PV model, Proteus, Arduino Uno, Solar radiation, Reference cell.

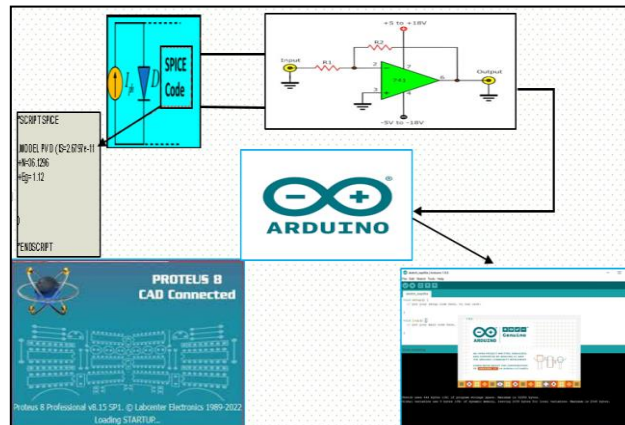

Graphical abstract

APPLICATION OF NEURAL NETWORKS SOLAR RADIATION PREDICTION (REGION OF M'SILA)

Badis Bakri<sup>1,\*</sup>, Hani Benguesmia<sup>2</sup>, and Zied Driss<sup>3</sup>

<sup>1</sup>Department of mechanical engineering, University of M'sila, Faculty of Technology, M'sila, Algeria.

<sup>2</sup>Electrical Engineering Laboratory (LGE), University of M'sila, M'sila, Algeria.

<sup>3</sup>Laboratory of Electromechanical Systems (LASEM), National School of Engineers of Sfax (ENIS), University of Sfax (US), Sfax, Tunisia.

ABSTRACT

The spectrum irradiance must be measured because different sunlight wavelengths (or colors) are absorbed in various regions of our atmosphere. Calculating different sun-related system performance, such as the size and performance of renewable energy systems, requires knowledge on solar irradiance. The goal of this work is to create a forecast model based on artificial neural networks in the M'sila area using actual meteorological data. The outcomes made it possible to choose this strategy due to its benefits that were tailored to the issue at hand.

**Keywords:** Renewable energies; artificial neural networks (RNN); prediction.

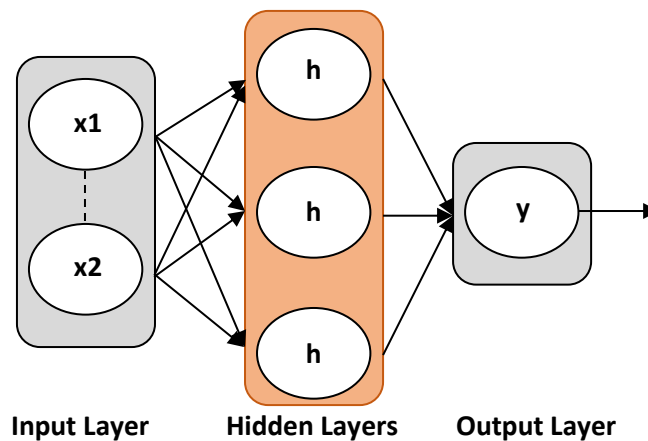

Graphical abstract



### SOLAR ENERGY POTENTIAL OF THE EASTERN ANATOLIA REGION AND THE CASE OF KARS PROVINCE

Neslihan AYDIN

Dr, Bursa Uludag University, Department of Machinery and Metal Technologies, Machinery Program, Bursa-Turkey,  
ORCID: 0000-0003-3650-0886

#### ABSTRACT

In today's world where global warming is at an extreme, the production and use of renewable energy sources, especially the use of solar energy systems, instead of conventional energy types, has become very popular. One of the most widely used areas of solar energy today is solar hot water systems. Approximately 3-4% of the energy used in residences is spent on hot water needs. Approximately 6-9% of the energy used in Turkey is used for hot water. Although the operating costs of solar hot water heating systems are almost non-existent, the biggest cost is the initial investment cost. As the initial investment cost pays off in a short time, hot water can be supplied from these systems for years. Many different methods are used in the design calculations of solar hot water systems. The basic principle in project planning is to determine the required collector area and to calculate the collector to be used. When more collectors are used than necessary, the initial investment cost will increase and the payback period of the system will increase. If fewer collectors are used than necessary, the desired amount of solar energy will not be utilized and the annual utilization rate of the system will be low.

In this study, the most preferred renewable energy sources, solar hot water systems, and the solar energy potential in the Eastern Anatolia Region were investigated. In addition, a solar hot water system project will be made for the solar hot water supply of a house in Kars in the Eastern Anatolia Region, which has solar energy potential, and monthly and annual solar thermal loads will be given.

**Keywords:** Solar Energy Potential, Eastern Anatolia Region, Solar Hot Water Systems, Annual Solar Thermal Load.

### DOĞU ANADOLU BÖLGESİNİN GÜNEŞ ENERJİSİ POTANSİYELİ VE KARS İLİ ÖRNEĞİ

#### ÖZET

Küresel ısınmanın had safhada olduğu günümüz dünyasında konvansiyonel enerji türleri yerine, yenilenebilir enerji kaynakları üretimi ve kullanımı özellikle bu türlerden güneş enerjisi sistemlerinin kullanımı oldukça popüler olmuştur. Güneş enerjisinin günümüzde en yaygın kullanılan alanlarından biri de Güneş enerjili sıcak su sistemleridir. Konutlarda kullanılan enerjinin yaklaşık olarak %3-4' ü sıcak su ihtiyaçları için harcanmaktadır. Türkiye' de kullanılan enerjinin yaklaşık %6-9' u sıcak su için kullanılmaktadır. Güneş enerjili sıcak su ısıtma sistemlerinin işletme masraflarının neredeyse yok denecek seviyede olmasına rağmen, bunun yanında en büyük maliyet masraf ise ilk yatırım maliyetidir. İlk yatırım maliyetinin ise kısa sürede kendini amorti etmesi ile yıllar boyunca bu sistemlerden sıcak su temin edilebilmektedir. Güneş enerjili sıcak su sistemlerinin projelendirme hesaplarında pek çok farklı metot kullanılmaktadır. Projelendirmedeki temel prensip gerekli kolektör alanının belirlenmesi ve kullanılacak kolektör hesabının yapılabilmesidir. Gereğinden fazla kolektör kullanıldığında ilk yatırım maliyeti artacak ve sistemin kendini amorti etme süresi artacaktır. Gereğinden az kolektör kullanılması durumunda ise güneş enerjisinden istenilen miktarda faydalanılamayacak ve yıllık faydalanma oranı sistemin düşük olacaktır.

Bu çalışmada, yenilenebilir enerji kaynaklarından en çok tercih edilen Güneş enerjili sıcak su sistemleri projelendirilmesine ve Doğu Anadolu Bölgesi'nde Güneş enerji potansiyeli araştırılmıştır. Ayrıca Güneş enerji potansiyeli bulunan Doğu Anadolu Bölgesi'nde Kars için bir evin güneş enerji ile sıcak su temini için Güneş



enerjili sıcak su sistemi projelendirmesi yapıp aylık ve yıllık elde edilebilecek güneş enerjisi ısı yükleri de verilecektir.

**Anahtar kelimeler:** Güneş Enerjisi Potansiyeli, Doğu Anadolu Bölgesi, Güneş Enerjili Sıcak Su Sistemleri, Yıllık Güneş Enerjisi Isıl Yükü.

## Giriş

Dünyamızda olduğu gibi ülkemizde de Güneş enerjisi oldukça yaygın kullanılan yenilenebilir enerji türlerinden birisidir. Enerji ihtiyaçlarını karşılama yönünden insanoğlu daha çok yenilemeyen fosil yakıtları tercih eder olmuştur. Dünya çapında enerji tüketimine bakıldığında, küresel enerjinin yarısına yakın kısmı %45'i endüstride tüketilmekte, %30'u ulaşımda, %22.5' u mesken ve konutlarda, diğer kalan kısmı da ticaret sektöründe kullanılmaktadır.

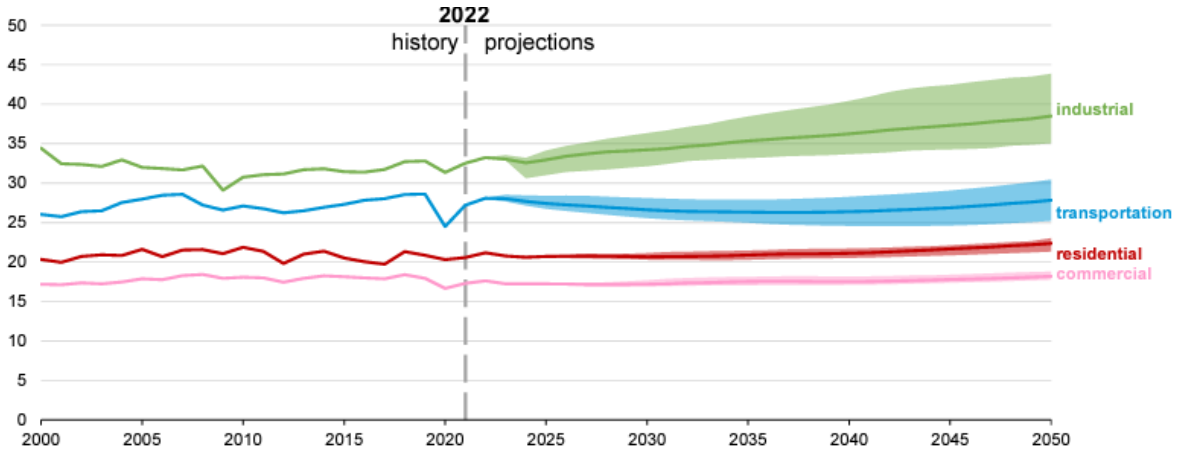

Şekil 1.2022 Son kullanılan enerji tüketimlerine göre sektörlerin dağılımı (EIA, 2023).

Güneş bizim temel enerji kaynağımızdır. Dünyada yılda yaklaşık 13.27 milyar ton petrol eşdeğeri (TEP) enerji kullanılmaktadır. (Ceylan & Gürel Etem A. 2018) Dünyada yıllık enerji tüketiminin %33.3'ü petrolden,%28.1'i kömürden, %24.1'i doğalgazdan, %4.4'ü nükleerden,%6.9'u hidrolikten ve geriye kalan %3.2'si yenilenebilir enerji kaynaklarından karşılanmaktadır (Yiğit & Atmaca, 2018). Türkiye Enerji İşleri Genel Müdürlüğü'nün yayınladığı Güneş Enerjisi Potansiyeli Atlası (GEPA) incelendiğinde, özellikle Doğu Anadolu Bölgesi'nin önemli bir Güneş Enerjisi Potansiyeline sahip olduğunu söylemek mümkündür. Ayrıca Kars ili için harita incelendiğinde ortalama1600-1650 kWh/m<sup>2</sup>-yıl Güneş enerjisi potansiyelinin olduğu anlaşılmaktadır.

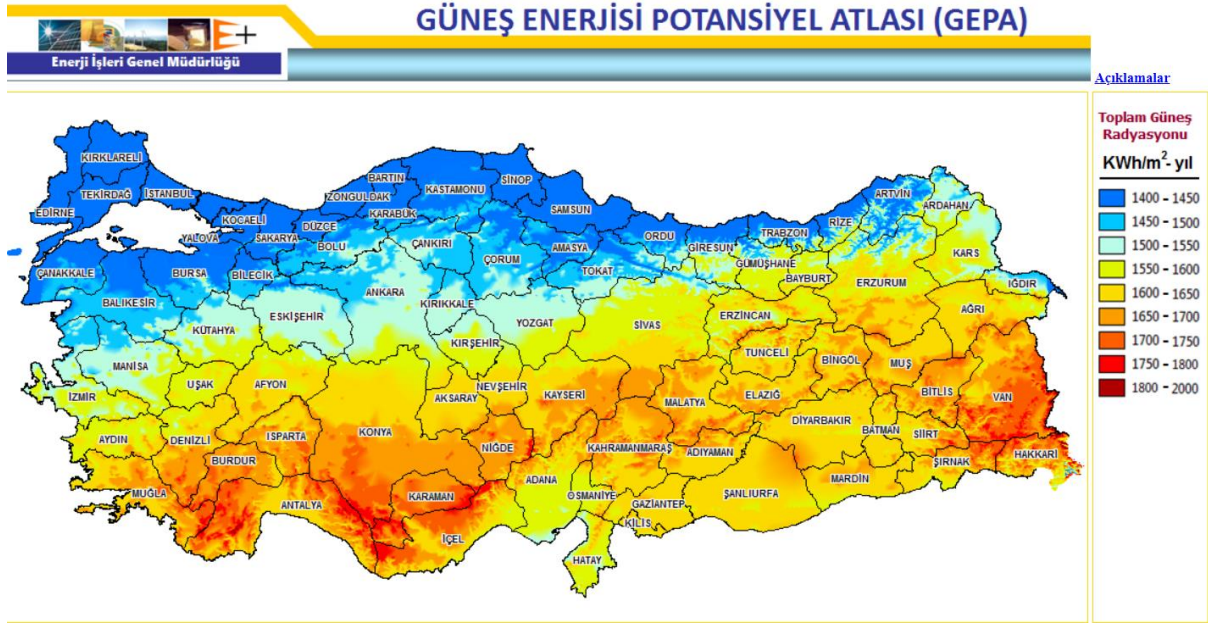

Şekil 2. Türkiye'nin Güneş Enerjisi Potansiyeli (GEPA, 2023) GEPA. 2023.

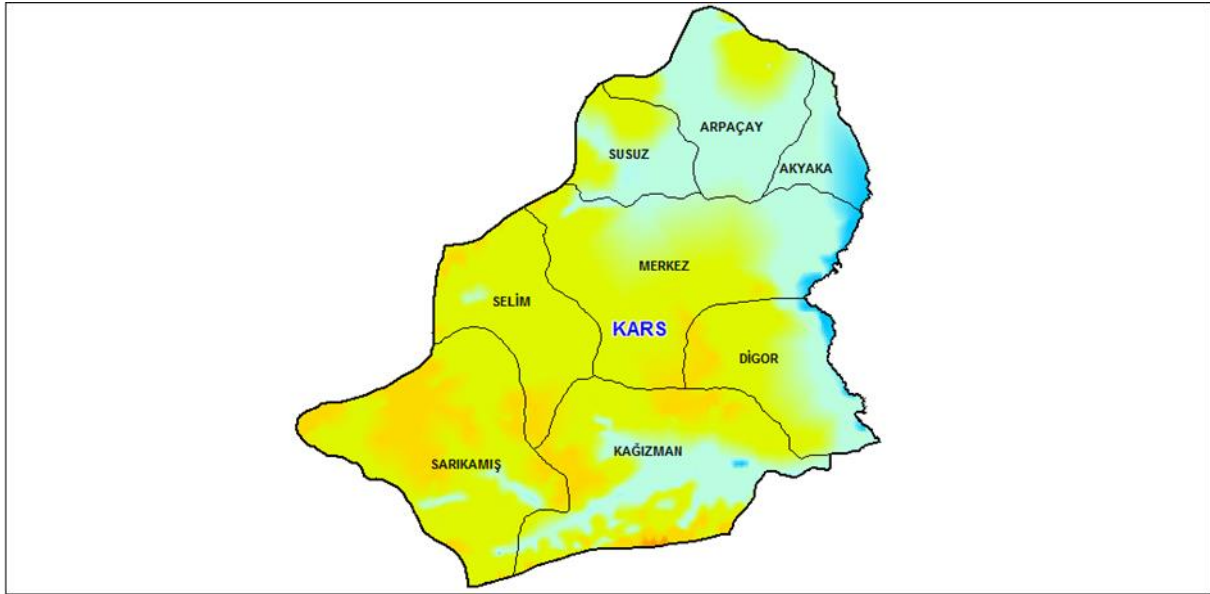

Şekil 3. Kars ili Güneş Enerjisi Potansiyeli (GEPA, 2023)

Bir yüzeye düşen güneş ışınımı miktarı, yüzeyin yönüne, bulunduğu yerin enlem ve yüksekliğine, havanın nemine, gökyüzünün açıklığına ve günün saatine bağlıdır (Kanoğlu, Cımbala & Çengel, 2022). Kars ili Doğu Anadolu Bölgesinin kuzey-doğu kesiminde, 42° 10' ve 44° 49' doğu boylamlarıyla, 39° 22' ve 41° 37' kuzey enlemleri arasında yer almaktadır. 10.127 km<sup>2</sup> yüzölçümüne sahip olan il, ülke topraklarının %1,3'ünü kaplamaktadır (Kars Stratejik Gelişme Raporu, 2008) .

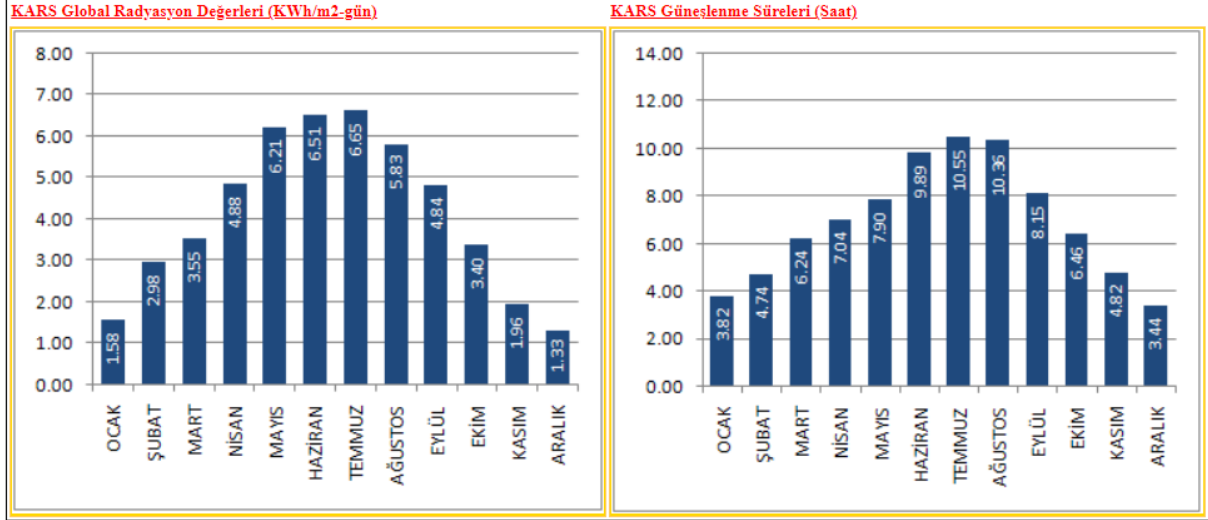

Şekil 4. Kars ili aylık Global Radyasyon değerleri (kWh/m<sup>2</sup>-gün) ve Güneşlenme süreleri (saat) (GEPA,2023).

### Materyal ve Yöntem

Güneş enerjili sistemlerin uygun olarak boyutlandırılması, hem kolektör ve diğer ekipmanların performans karakteristikleri gibi tahmin edilebilir, hem de dış ortam şartları gibi kolay tahmin edilemeyen parametreleri içermesinden dolayı oldukça karmaşık bir problemidir. Güneş enerjili sıcak su sistemlerinin projelendirilmesinde uygun bir hesaplama tekniği olan f-chart metodu kullanılacaktır.

### f-Chart Metodu

Bu metot, uzun süreler boyunca yapılan ısı performanslarının simülasyonların sonuçlarının korelasyonu elde edilmiştir (Duffie & Beckman 2013). Duffie, J.A. and Beckman, W.A. Solar Engineering of Thermal Processes, 4th edition, 2013. Hoboken New Jersey: John Wiley & Sons, Inc. Birincil dizayn parametresi kolektör alanı iken, ikincil değişkenler kolektör tipi, depolama kapasitesi ve gerekli ısı yük olarak belirlenir. Kurulacak alana bağlı olarak, uygun kolektör yüzey alanı ve tipi seçilmemesi durumunda, güneş enerjisinden faydalanma oranı düşecek istenen su sıcaklığı tam olarak sağlanamayacak, gereğinden fazla kolektör yüzey alanının kullanılması durumunda ise fazladan enerji birikimi olacak ve sistem ekonomik olmayacaktır.

Aylık ısı ihtiyacının güneş enerjisinden karşılanma oranı f-chart yöntemiyle iki bağımsız değişken olan X ve Y ye bağlı olarak tanımlanmaktadır (Beckman et al. 1977).

$$f = 1.029Y - 0.065X - 0.245Y^2 + 0.018X^2 + 0.0215Y^3$$

İki boyutsuz değişken X ve Y şu şekilde tanımlanmaktadır:

$$X = \frac{A_C F'_R U_L (T_{ref} - T_\alpha) \Delta \tau}{L}$$

$$Y = \frac{A_C F'_R (\tau \alpha) H_T N}{L}$$

veya

$$X = F_R U_L x \left( \frac{F'_R}{F_R} \right) x (T_{ref} - T_\alpha) x \Delta \tau x \frac{A_C}{L}$$

$$Y = F_R (\tau \alpha)_n x \frac{F'_R}{F_R} x \frac{(T_\alpha)}{(T_\alpha)_n} x H_T x N x \frac{A_C}{L}$$

Bu ifadelerdeki değişkenler şu şekilde sıralanabilir;

$F_R U_L$  = Sistemde kullanılacak olan kolektörün verim eğrisinin eğimi

$F_R (\tau\alpha)_n$  = Sistemde kullanılacak olan kolektörün verim eğrisinin y eksenini kestiği nokta

$\frac{F'_R}{F_R}$  = Kolektör ile depolama tankı arasındaki çeşitli sıcaklık düşüşleri için düzeltme faktörü. Değeri 0.97 dir.

$\frac{(T_\alpha)}{(T_\alpha)_n}$  = Aylık yutma geçirme katsayısıdır. Tüm aylar için yapılacak hesaplamalarda bu değer tek cam örtülü güneş kolektörleri için 0.96 olarak alınabilir.

$T_{ref}$  = Ampirik referans sıcaklık ve değeri 100 °C dir.

$T_\alpha$  = Aylık ortalama çevre sıcaklığı(°C)

$\Delta\tau$  = Bir aydaki toplam saniye cinsinden zaman (saniye)

$A_C$  = Kolektör alanı (m<sup>2</sup>)

$L$  = Aylık toplam su ısıtma yükü (J)

$H_T$  = Kolektörün birim alanına düşen aylık ortalama günlük güneş ışımasını (J/m<sup>2</sup>) (Yiğit&Atmaca2018)

$N$  = Aydaki gün sayısı

KARS	Ocak	Şubat	Mart	Nisan	Mayıs	Haziran	Temmuz	Ağustos	Eylül	Ekim	Kasım	Aralık	Yıllık
Ölçüm Periyodu ( 1931 - 2022)													
Ortalama Sıcaklık (°C)	-10.8	-8.9	-2.9	5.2	10.3	14.0	17.6	17.8	13.7	7.4	0.5	-6.9	4.8
Ortalama En Yüksek Sıcaklık (°C)	-4.9	-2.7	2.8	11.4	16.9	21.2	25.6	26.4	22.3	15.1	6.8	-1.4	11.6
Ortalama En Düşük Sıcaklık (°C)	-16.3	-14.7	-8.2	-0.6	3.9	6.7	9.9	9.8	5.4	0.5	-4.8	-11.8	-1.7
Ortalama Güneşlenme Süresi (saat)	3.2	4.3	5.1	6.0	7.3	9.3	10.3	10.0	8.4	6.2	4.6	3.1	6.5
Ortalama Yağışlı Gün Sayısı	10.60	10.07	11.64	13.28	18.19	14.72	10.42	8.61	7.10	9.62	8.48	10.13	132.9
Aylık Toplam Yağış Miktarı Ortalaması (mm)	22.9	23.2	30.0	48.8	82.7	76.7	56.3	43.9	29.4	41.9	27.3	22.9	506.0
Ölçüm Periyodu ( 1931 - 2022)													
En Yüksek Sıcaklık (°C)	9.1	12.0	19.1	25.0	28.3	33.9	35.6	37.1	33.0	26.8	21.9	15.9	37.1
En Düşük Sıcaklık (°C)	-36.7	-37.0	-31.5	-22.6	-7.0	-4.0	0.1	-1.9	-4.4	-17.5	-30.0	-35.0	-37.0

Şekil 5. Kars ili aylık ve yıllık ortalama çevre sıcaklığı ve güneşlenme süresi değerleri (MGM, 2023).

Aylık su ısıtma yükü iki kısımda incelenebilir. Birincisi şebeke suyu sıcaklığını istenen su sıcaklığına çıkarmak için gerekli enerji, ikincisi ise depolama tankından olan kayıplardır. Şebeke suyu sıcaklığını istenen su sıcaklığına çıkarmak için gerekli enerji miktarı için;

$$Q = m \cdot c_p (T_W - T_m) N \quad (J)$$

Burada m (kg) su kütlesi,  $c_p$  (J/kg°C) suyun özgül ısısı,  $T_W$  (°C) istenen su sıcaklığı,  $T_m$  (°C) aylık ortalama şebeke suyu sıcaklığı ve N ise aylık gün sayısıdır. Aylık ortalama şebeke suyu sıcaklığı Kars Sarıkamış ilçesi aylık ortalama şebeke suyu sıcaklığı alınacaktır (İrdemez et al 2021).

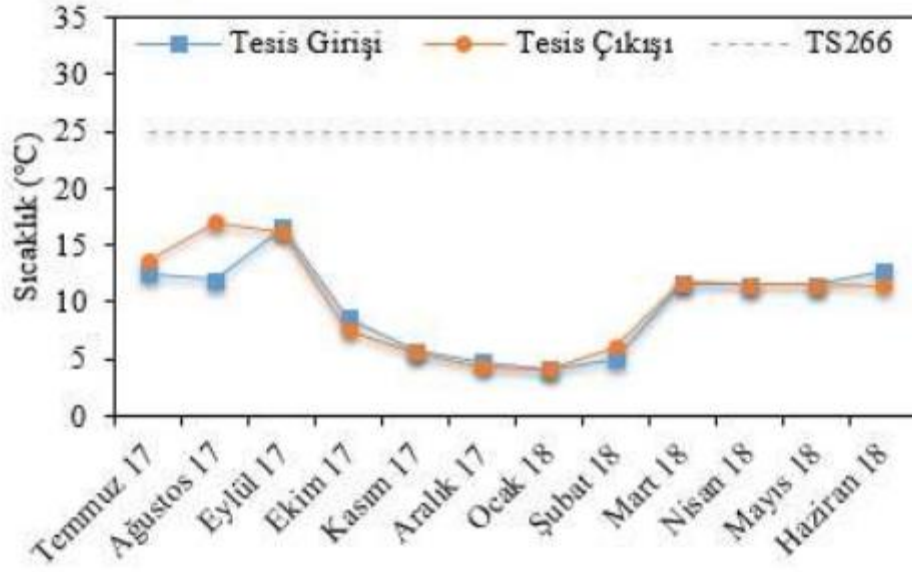

Şekil 6. Kars Sarıkamış ilçesi şebeke içme suyu tesisi giriş ve çıkış sıcaklıkları ortalamaları Temmuz 2017/ Haziran 2018 (İrdemez et al. 2021)

Güneş enerjili sıcak su sistemlerinin projelendirilmesinde, boyutsuz değişken  $X$  için bir düzeltme katsayısı kullanılır. Şebeke suyu sıcaklığı  $T_m$  ve istenen minimum su sıcaklığı  $T_w$  güneş enerjili su ısıtma sisteminin performansını etkileyen parametrelerdir. Hem şebeke suyu sıcaklığı hem de istenen minimum su sıcaklığı sistemin ortalama işletme sıcaklığı seviyesini ve böylece kolektörden olan enerji kayıplarını etkiler. Kolektörden olan enerji kayıpları ile ilişkili olan  $X$  boyutsuz sayısı bu etkileri de içerecek şekilde düzeltilmelidir. Düzeltme faktörü:

$$\frac{X_c}{X} = \frac{(11.6 + 1.18T_w + 3.86T_m - 2.32T_a)}{(100 - T_a)}$$

Şeklinde tanımlanabilir. Aylık faydalanma oranı  $f_i$  ve aylık su ısıtma yükü  $L_i$  her ay için ayrı ayrı belirlendikten sonra yıllık faydalanma oranı  $F$  şu şekilde belirlenir:

$$F = \frac{\sum_{i=1}^{12} f_i L_i}{\sum_{i=1}^{12} L_i}$$

Bu yöntemde genellikle kolektör  $m^2$  si başına ısıtılacak su kütlesi için bir değer kabul edilir. Hesaplamalarda genellikle  $75lt/m^2$  ile başlanır. Sonuçlara göre bu değer artırılabilir veya azaltılabilir. Kolektör sayısı tespit edilirken sistemde enerji fazlalığına izin verilmemelidir.

### Bulgular ve Tartışma

TRA2 Bölgesi (Ağrı, Ardahan, Iğdır, Kars) coğrafi konumu nedeniyle sahip olduğu güneş enerjisi potansiyeli açısından şanslı bir durumdadır. Serhat Kalkınma Ajansının raporuna göre Doğu Anadolu Bölgesi ülkemizde güneş enerjisi potansiyeline göre en yüksek bölgelerden olan Güneydoğu Anadolu Bölgesi ve Akdeniz Bölgesi'nden sonra 3. sırada gelmektedir. Bölgede güneş enerjisi potansiyelleri sırasıyla Ağrı, Iğdır, Kars ve Ardahan olarak gözükmektedir. İllerin rakımlarının yüksek olması havadaki su buharının yağmur ve kar şeklinde yoğunlaşmasını sağlarken, atmosferdeki ışınım perdelenmesini daha az seviyede tuttuğu söylenmektedir (Uslu & Erkan 2015).

Bu çalışmada Doğu Anadolu Bölgesi'nde Kars'ta bulunan bir konut için sıcak su ihtiyacı güneş enerjili sıcak su sistemi tasarlanacaktır. Sistemin tasarımı f-chart metodu ile yapılacaktır.

Kars için  $\phi = 40.61^\circ$  enleminde yer alan 500 lt sıcak su ihtiyacı olan bir ev için güneş enerjili sıcak su sistemi tasarlanacaktır. Sistemden istenen su sıcaklığı  $T_W = 50^\circ C$ , depolama tankı için toplam ısı transfer katsayısı  $U=0.62W/m^2K$ , tasarımda kullanılacak olan tek cam örtülü ve eğimi konumun enlem açısına eşit olan kolektörlerin verim parametreleri ise;  $F_R(\tau\alpha)_n = 0,84$  ve  $F_R U_L = 4.5 \frac{W}{m^2}K$  için Ocak ayı için;

Kolektörün 90 lt su ısıtma kapasitesi olduğunu varsayarak;

$$A_c = \frac{500}{90} = 5.5 m^2 \cong 6 m^2$$

Kars için Ocak ayı şebeke suyu sıcaklığı ortalama Şekil 6' dan;  $T_m = 5^\circ C$  bu suyu istenilen sıcaklığa çıkarmak için gerekli olan aylık enerji hesaplanırsa;

$$Q = m \cdot c_p (T_W - T_m) N = 500 * 4190 * (50 - 5) * 31 * \frac{GJ}{10^9 J} = 2.9225 GJ$$

Depo tankından olan kayıpların tespiti için önce depo tankının boyutlarının tespiti gerekir. 500lt yani 0.5 m<sup>3</sup> lük bir depo gereklidir. Depo çapını 0.7 m olarak kabul edersek, gerekli depo boyu;

$\pi r^2 l = 0.5 m^3$ ,  $r=0.35m$ ,  $l \cong 1.3 m$  ve depo yüzey alanı  $A_{depo} = 2\pi r^2 + 2\pi r l = 3.6 m^2$  olarak bulunur. Kars için Ocak ayı için ortalama hava çevre sıcaklığı Şekil 5.' e bakıldığında  $T_\alpha = -10.8^\circ C$  olduğuna göre depodan olan ısı kaybı;

$$Q_{kayıp} = UA(T_W - T_\alpha) = 0.62 * 3.6 * (50 - (-10.8)) = 135.705 W$$

Bu kaybı karşılamak için gerekli aylık enerji;  $\frac{135.705 * 31 * 24 * 3600}{10^9} = 0.363 GJ$  olarak bulunur. Aylık toplam ısı yük ise;  $L_i = L_{ocak} = 2.9225 + 0.363 = 3.285525 GJ$  olarak hesaplanır.

Aylık faydalanma oranının tespitinde kullanılan boyutsuz değişkenlerden X;

$$X = 4.5 * 0.97 * (100 - (-10.8)) * (31 * 24 * 3600) * \frac{6}{3.285525 * 10^9} \cong 2.36$$

$$\frac{X_c}{X} = \frac{(11.6 + 1.18 * 50 + 3.86 * 5 - 2.32 * (-10))}{(100 - (-10))} \cong 1.03 \quad X_c = X * \frac{X_c}{X} = 2.36 * 1.05 \cong 2.484$$

Diğer boyutsuz değişken  $Y = 0.84 * 0.97 * 0.96 * 7.897 * 10^6 * 31 * \frac{6}{3.285525 * 10^9} \cong 0.35$

X boyutsuz sayısı yerine  $X_c$  yazılarak aylık yararlanma oranı;

$$f_{ocak} = 1.029 * 0.35 - 0.065 * 2.484 - 0.245 * 0.35^2 + 0.018 * 2.484^2 + 0.0215 * 0.35^3 = 0.281 \text{ elde edilir.}$$

Diğer aylar içinde hesaplamalar yapılmış tabloda sonuçlar verilmiştir.

**Tablo 1.** Kars için Güneş enerjisi ile ısıtma sistemi konut tasarımı için f-chart metodundan elde edilen sonuçlar

Aylar	$T_a(^{\circ}C)$	$T_m(^{\circ}C)$	$H_r$ (MJ/m <sup>2</sup> -gün)	$L_i$ (GJ)	$X_c$	Y	f	$f_i L_i$ (Gj)
OCAK	-10.8	5	7.897	3.28	2.48	0.35	0.281	0.92
ŞUBAT	-8.9	<b>7.5</b>	10.929	2.84	2.67	0.474	0.389	1.11
MART	-2.9	8	14.400	3.03	2.38	0.684	0.536	1.63
NİSAN	5.2	12	16.080	2.64	2.99	0.857	0.682	1.80
MAYIS	10.3	12	18.000	2.65	2.46	0.988	0.747	1.98
HAZİRAN	14	13	20.400	2.53	2.58	1.238	<b>0.927</b>	2.34
TEMMUZ	17.6	14	21.135	2.53	2.33	1.215	0.873	2.21
AĞUSTOS	17.8	17	19.277	2.33	2.85	1.204	0.882	2.05
EYLÜL	13.7	15	16.080	2.41	2.73	0.939	0.725	1.75
EKİM	7.4	8	11.265	2.98	1.93	0.549	0.436	1.30
KASIM	0.5	6	7.680	3.05	2.06	0.354	0.307	0.94
ARALIK	-6.9	3	6.619	3.39	2.03	0.280	0.213	0.72
TOPLAM				33.66				18.75

$$F = \frac{18.75}{33.66} = 0.557$$

6 m<sup>2</sup>lik kolektör yüzeyi ile elde edilen yıllık yararlanma oranı;

%55 olarak tespit edilmiştir.

### Sonuç ve Öneriler

Kars ili, yüksek ve engebeli arazileriyle, sert karasal iklimin etkisindedir. Bu yüzden iklim şartlarından dolayı beşeri ve ekonomik faaliyetler oldukça kısıtlanmıştır. Buna rağmen il ekonomisi, büyük ölçüde hayvancılık faaliyetleri ve kamusal istihdam ile idame edilmektedir. Enerji ve Tabii Kaynaklar Bakanlığınca Türkiye güneş enerjisi üretimine veri kaynağı oluşturması amacıyla hazırlanan, Güneş Enerjisi Potansiyeli Atlası (GEPA) verilerine göre, Kars ili genelinin ortalama yıllık toplam ışınım değeri 1,472 kWh/m<sup>2</sup> olup Türkiye genelindeki 1527,46 kWh/m<sup>2</sup> ortalama değerinin altındadır (YEGM 2022). Buna rağmen Kars ilinde Selim ve Sarıkamış ilçeleri sınırları dâhilinde toplam 5,74 MWe güce sahip üç GES santrali üretim faaliyetlerine devam etmektedir. Güneş enerjisi potansiyeline ve enerji nakline bakıldığında, Kars ilinde mevcut 8 ilçe merkezi 383 köy yerleşimi bulunması ve bu yerleşimlerin homojen bir dağılımı göstermesi nedeniyle enerji nakil hatları da bu dağılıma uygun olarak oldukça homojen ve sık bir dağılım göstermektedir. Bu durum nedeniyle Kars ilinde yapılacak güneş enerjisi santrallerinin yer seçiminde enerji nakil hatlarının dağılımı bir kısıtlama oluşturmamaktadır (Demir 2023).

Sonuç olarak Doğu Anadolu Bölgesinin Güneş enerjisi potansiyeli oldukça yüksek, elverişlidir. Sert karasal iklimin aksine GEPA ve devlet meteorolojinin verilerine dayanarak, Kars ili için yüzde %55 faydalanma oranı ile oldukça yüksek bir oran ile güneş enerjisinden faydalanılıp sıcak su eldesi sağlanabilmektedir.

### Kaynaklar

Beckman W.A, Klein S.A., Duffie J.A (1977), Solar Heating Design by the f-chart method, Wiley-Interscience, New York.

Ceylan İ., Gürel Etem A. (2018) Güneş Enerjisi Sistemleri ve Tasarımı, Dora Yayınları, Bursa.

Demir M. (2023) Determination of Areas with Solar Power Plant Installation Potential in Kars Province by Using GIS Analysis and AHP Method. Journal of Geography, 2023, 46: 93-109. <https://iupress.istanbul.edu.tr/en/journal/jgeography/home> son erişim tarihi: 01.09.2023

Energy Information Administration (EIA), 2023. <https://yearbook.enerdata.net/total-energy/world-consumption-statistics.html> son erişim tarihi: 01.09.2023

Güneş Enerjisi Potansiyeli Atlası (GEPA), 2023. <https://gepa.enerji.gov.tr/MyCalculator/> son erişim tarihi:01.09.2023

İrdemez Ş., Özger H., Ekmekyapar Torun F., Kul S., 2021. Bitlis Eren Üniversitesi Fen Bilimleri Dergisi 10 (1), 235-248, 2021.

Kanoğlu M., Çengel Y., Cimbala J.M. (2022) Yenilenebilir Enerji Temelleri ve Uygulamaları, Palme Yayınevi.

Kars Stratejik Gelişme Raporu (2008) <https://www.serka.gov.tr/assets/upload/dosyalar/tkb---kars-stratejik-gelisme-raporu-2008.pdf> son erişim tarihi:05.09.2023

Kars İli Güneş Enerjisi Potansiyeli Atlası (GEPA,KARS) 2023 <https://gepa.enerji.gov.tr/MyCalculator/pages/36.aspx> / son erişim tarihi:01.09.2023

Meteoroloji Genel Müdürlüğü (MGM), 2023. <https://www.mgm.gov.tr/veridegerlendirme/il-ve-ilceler-istatistik.aspx?m=KARS> son erişim tarihi:03.09.2023

Uslu D. Y. & Erkan U. (2015). Doğu Anadolu İçin Yeni Atılım: Yeşil Enerji. I. International Caucasus-Central Asia Foreign Trade and Logistics Congress Proceeding Book, E-ISBN: sayfa:15-26.

YEGM (2022) TC Enerji ve Tabii Kaynaklar Bakanlığı, Yenilenebilir Enerji İşleri Genel Müdürlüğü <https://enerji.gov.tr/eigm-yenilenebilir-enerji-kaynaklar-gunes> son erişim tarihi:03.09.2023

Yiğit A., Atmaca İ. (2018). Güneş Enerjisi Mühendislik Uygulamaları, Dora Yayınları, Bursa.





### INVESTIGATION OF SOLAR ENERGY IN SUPPORTING THE HEATING AND ELECTRICITY NEEDS OF A FACULTY BUILDING

**Enes MAVİ**

Dumlupınar University, Faculty of engineering, Department of Mechanical Engineering, Kütahya-Türkiye  
ORCID: 0009-0002-0616-2943

**Halit ARAT**

Research Assistant, Dumlupınar University, Faculty of Engineering, Department of Mechanical Engineering Kütahya-Türkiye  
ORCID: 0000-0002-6634-2535

**Oğuz ARSLAN**

Prof. Dr Bilecik Şeyh Edebali University, Faculty of Engineering, Department of Mechanical Engineering Bilecik-Türkiye  
ORCID: 0000-0001-8233-831X

#### ABSTRACT

Central heating is a heating method used to keep a building or multiple independent parts of buildings at the desired ambient temperature depending on the outdoor temperature by using a single heat source. Central heating systems are a more suitable and more economical option, especially for large buildings. In these systems, which are generally operated by using fossil fuels, renewable energy sources are also used as a supplement. Renewable energy sources have the potential to make a significant contribution to support both electricity and heating needs. One of the renewable energy sources with developing and widespread use is solar energy. In this study, the use of solar energy to support the heating and electricity needs of a faculty building with a central heating system was investigated. It is aimed to provide heat and power generation by placing plate solar collectors and photovoltaic panels on the empty spaces next to the faculty buildings. In the study, an empty area in front of the faculty; the design of three different scenarios, including plate collector or photovoltaic panel in the whole and a photovoltaic panel in the half with a plate collector in the half, are discussed. According to the results, the monthly consumption ratios of the heat and electrical energies obtained in three different scenarios were calculated and the best scenario was determined.

**Keywords:** Flat-plate collector, Photovoltaic, Solar energy, Central heating.



### STUDY ON THE USAGE OF SOLAR ENERGY IN SUPPORTING THE ELECTRICITY NEEDS OF THE ENGINEERING FACULTY BUILDING OF KUTAHYA DUMLUPINAR UNIVERSITY

**Enes MAVİ**

Dumlupınar University, Institute of Graduate Education, Department of Mechanical Engineering ,Kütahya-Türkiye  
ORCID: 0009-0002-0616-2943

**Halit ARAT**

Asst. Prof. Dr., Dumlupınar University, Faculty of Engineering, Department of Mechanical Engineering, Kütahya-Türkiye  
ORCID: 0000-0002-6634-2535

**Oğuz ARSLAN**

Prof .Dr., Bilecik Şeyh Edebali University, Faculty of Engineering, Department of Mechanical Engineering, Bilecik-Türkiye  
ORCID: 0000-0001-8233-831X

#### ABSTRACT

Renewable energy is a type of energy that can be produced continuously using natural resources and is not extinct. These energy resources are that exist indefinitely or that can be rapidly renewed. Renewable energy sources are generally considered environmentally friendly because there are less or no negative stress effects such as greenhouse emissions. One of the renewable energy sources with developing and widespread use is solar energy. In this study, the use of solar energy to support the electricity needs of Kütahya Dumlupınar University Engineering Faculty buildings was investigated. It is aimed to provide power generation by placing photovoltaic panels on the parking area next to the faculty buildings. Moreover, the parking area of B-D Block, which is 2205 m<sup>2</sup> in total; photovoltaic panels were applied to all of them. According to the results, the net present value calculation, which expresses the difference between the present value of the project's return and the investment amount, was made. Also, the payback period of the photovoltaic solar panel investment was calculated and the feasibility of the investment was revealed.

**Keywords:** Electricity supporting, Photovoltaic, Solar energy, Net present value.



### LİSANSIZ ÇATI VE CEPHE GÜNEŞ ENERJİSİ SANTRALİ PROJE BAŞVURULARININ DEĞERLENDİRİLMESİ

**Abdullah ZORLU**

Kocaeli Üniversitesi, Fen Bilimleri Enstitüsü, Enerji Sistemleri Mühendisliği Bölümü, Kocaeli-Türkiye. (Sorumlu Yazar)  
ORCID: 0000-0002-7453-6321

**Mustafa ÖZCAN**

Doç. Dr., Kocaeli Üniversitesi, Teknoloji Fakültesi, Enerji Sistemleri Mühendisliği Bölümü, Kocaeli-Türkiye,  
ORCID: 0000-0001-6436-6368

#### ÖZET

Elektrik enerjisi üretiminde fosil yakıt kullanılması sera gazı emisyonlarına sebep olurken, iklim değişikliği ve çevre kirliliği meydana getirmektedir. Fosil yakıt tüketimi ile oluşacak yıkıcı etkilerinin önlenmesi için; yenilenebilir enerji kaynakları (YEK) kullanarak elektrik enerjisi üretimi tercih edilmektedir. Elektrik Piyasası Kanunu kapsamında yapılan mevzuat düzenlemeleri ile elektrik üretimi faaliyetinde bulunmak isteyen kişilere lisanssız elektrik üretim tesisi kurma imkanı sunulmuştur. Bu kapsamda, meskenlerdeki elektrik tüketimini karşılamak amacıyla, çatı ve cephelere 25 kW ve altı kurulu güç değerinde güneş enerji santrali (GES) kurulabilmektedir. Görevli elektrik dağıtım şirketi (EDAŞ)'lara yapılan çatı ve cephe GES başvuruları incelendiğinde reddedilen proje sayılarının fazla olduğu görülmüştür. Türkiye'nin GES kurulu gücünün artırılması için başvuru red oranlarının azaltılması gereklidir. Bu çalışmada; 2018-2022 yılları arasında Marmara Bölgesi içerisinde yer alan EDAŞ'lara yapılan, 25 kW ve altı kurulu güç değerindeki çatı ve cephe GES başvurularının sonuçları değerlendirilmiştir. Marmara Bölgesi'nde 2018 yılında toplam 101 adet başvuru yapılmıştır. Yapılan başvuruların %67,33'ü kabul edilirken, %32,67'si reddedilmiştir. 2022 yılında toplam 850 adet başvuru yapılmıştır. 2022 yılında en fazla başvuru 265 proje ile Uludağ EDAŞ'a yapılmıştır. 2022 yılında Marmara Bölgesi'nde yapılan tüm başvuruların %76,59'u kabul edilirken, %23,41'i reddedilmiştir. 2022 yılında en fazla proje kabulü 211 proje ile Sakarya EDAŞ'a yapılan başvurularda elde edilmiştir. 2022 yılında yapılan başvurularda en fazla ret Anadolu Yakası EDAŞ ve Uludağ EDAŞ'ta olmuştur. Yapılan başvuru sayısı ve kabul oranları artış göstermektedir. 2022 yılında yapılan başvuru sayıları 8,4 kat artarken kabul oranı %9,26 artmıştır. 2018-2022 yılları arasında yapılan başvurularda en fazla ret, proje ile faaliyet yasağına ilişkin beyanın hatalı ve formun farklı biçimde hazırlanması sonucu gerçekleşmiştir. EDAŞ'larda proje değerlendirmesi ve inceleme süreçlerini hızlandırmak için, proje başvuruları online sisteme taşınmalı, ön başvuru sistemi oluşturularak aboneliğin uygunluğu değerlendirilmelidir.

**Keywords:** Lisanssız Elektrik Üretimi, Çatı ve Cephe, Elektrik Dağıtım Şirketi, Güneş Enerjisi Santrali, Sürdürülebilir Kalkınma Hedefi

#### ABSTRACT

The use of fossil fuels in electrical energy generation causes greenhouse gas emissions, climate change and environmental pollution. In order to prevent the destructive effects of fossil fuel consumption, electricity generation using renewable energy sources (RES) is preferred. With the legislative arrangements made within the scope of the Electricity Market Law, the opportunity to establish unlicensed electricity generation facilities has been offered to those who wish to engage in electricity generation activities. In this context, solar power plants (SPPs) with an installed capacity of 25 kW or less can be installed on rooftop and facades to meet the electricity consumption of households. When the applications for rooftop and facade SPPs made to the incumbent electricity distribution companies (EDCs) are analysed, it is seen that the number of rejected projects is high. In order to increase Turkey's SPP installed capacity, application rejection rates should be reduced. In this study, the results of rooftop and facade SPP applications with an installed capacity of 25 kW and below made to EDCs in the Marmara Region between 2018 and 2022 were evaluated.

A total of 101 applications were made in the Marmara Region in 2018. While 67.33% of the applications were accepted, 32.67% were rejected. A total of 850 applications were made in 2022. In 2022, the highest number of applications was made to Uludağ EDC with 265 projects. In 2022, 76.59% of all applications made in the Marmara Region were accepted, while 23.41% were rejected. In 2022, the highest project acceptance was obtained in applications made to Sakarya EDC with 211 projects. In 2022, the highest number of rejections was in Anadolu Yakası EDC and Uludağ EDC. The number of applications and acceptance rates are increasing. While the number of applications made in 2022 increased 8.4 times, the acceptance rate increased by 9.26%. In the applications made between 2018 and 2022, the highest number of rejections occurred as a result of incorrect declaration regarding the prohibition of activity with the project and preparation of the form in a different format. In order to speed up the project evaluation and review processes in EDCs project applications should be moved to the online system and the eligibility of the subscription should be evaluated by creating a pre-application system.

**Keywords:** Unlicensed Electricity Generation, Rooftop and Facade, Electricity Distribution Company, Solar Energy Plant, Sustainable Development Goal

### 1.Giriş

Dünya genelinde sanayileşme, nüfus artışı, teknolojik gelişmeler ve yüksek yaşam standartları gibi etkenler enerji talebini artırmaktadır. Enerji talebindeki artış, doğal kaynakların tükenmesi, çevre kirliliği ve yüksek enerji maliyetlerini beraberinde getirmektedir (Sağbaş & Başbuğ, 2018). Fosil yakıt kaynaklarının sınırlı olması yenilenebilir enerji kaynakları (YEK)'lere yönelimi beraberinde getirmektedir (Özyakışır & Ünver, 2020).

Dünya genelinde 1990 yılında 8.774 milyon ton eşdeğer petrol (Mtep) birincil enerji tüketimi gerçekleşmiştir (Enerdata, 2023). 2021 yılında dünyada birincil enerji tüketim miktarı 1990 yılına göre %62,01 artış göstererek 14.214,91 Mtep olmuştur. 2021 yılında bir önceki yıla göre %5,52'lik bir tüketim artışı olduğu gözlemlenmiştir. 2021 yılında gerçekleşen birincil enerji tüketiminde, ham petrol %30,92 ile ilk sırada yer almıştır. Bu kaynağı sırasıyla, kömür %26,92, doğalgaz %24,42, hidroelektrik %6,77, yenilenebilir kaynaklar %6,72 ve nükleer enerji %4,25 oran ile izlemiştir. (REN21, 2023).

Avrupa Birliği (AB) elektrik enerjisi tüketiminin toplam küresel enerji tüketimi içindeki oranı %10,10'dur. AB'de elektrik enerji tüketiminin kaynaklara göre dağılımında; %35,07'si petrol, %23,76'u doğalgaz, %13,17'si yenilenebilir enerji, %11,21'i kömür, %11,01'i nükleer enerji ve %5,39'u hidroelektrik enerji kaynaklıdır.

Türkiye'deki elektrik enerjisi tüketiminin, 2021 yılı küresel elektrik tüketimi içindeki oranı %1,15'tir. Türkiye'de tüketimlerin kaynaklara göre dağılımında; %30'u doğalgaz, %27,71'i petrol, %25,51'i kömür, %8,94'ü diğer YEK ve %7,64'ü hidroelektrik enerji kaynaklıdır (REN21, 2023).

Dünya genelinde her yıl gerçekleşen tüketim artışlarını karşılamak için elektrik enerjisi santral yatırımları yapılmaktadır. Kurulması planlanan elektrik enerjisi santrallerinin YEK'ler ile üretim yapması, fosil yakıt tüketimi ile oluşan sera gazı emisyonlarının azaltımına katkı sağlayacaktır (BP, 2023).

Dünya genelinde bir önceki yıla göre 2021 yılında %5,86'lık bir elektrik üretim artışı olmuştur. 2021 yılında dünya genelinde üretilen elektrik enerjisi miktarı 28.466,3 TWh'dir. Elektrik üretiminde, kömür %35,99'luk oran ile ilk sırada, doğalgaz %22,90 ise ikinci sırada yer almaktadır. Hidroelektrik santral (HES)'ler ile elde edilen elektrik üretiminin oranı %15,01 olup, diğer YEK'lerin toplam elektrik üretimindeki oranı %11,53'tür (BP, 2023).

AB, küresel elektrik üretiminin %10,17'sini oluşturmuştur. Elektrik üretiminin kaynaklara göre dağılımında en yüksek payı %25,29'luk oran ile nükleer enerji oluşturmuştur. AB elektrik üretiminin %25,22'si YEK'ler, %18,93'i doğalgaz, %15,17'si kömür, %2,02'si diğer kaynaklar ve %1,48'i petrol kullanılarak gerçekleştirilmiştir (BP, 2023).

2014 yılına göre dünyada, YEK kurulu gücünde artış yaşanmıştır. 2021 yılında elektrik kurulu gücünde 2014 yılına göre %83,76 artış olmuştur 2014 yılında; HES'ler dahil kurulu güç değeri 1.712 GW iken, 2021 yılı sonunda kurulu güç değeri 3.146 GW seviyesine yükselmiştir (REN21, 2023). 2021 yılında; 175 GW güneş

enerjisi santrali (GES), 100 GW rüzgar enerjisi santrali (RES), 10 GW biyokütle enerji santrali (BES), 27 GW HES, 0,3 GW jeotermal enerji santrali (JES) devreye alınmıştır. (REN21,2023).

2021 yılında enerji yatırımları için 365,9 milyar Amerika Birleşik Devletleri (ABD) doları bütçe kullanılmıştır. Enerji yatırımlarına ait bütçenin %69'unu YEK yatırımları için kullanılmıştır. YEK'lere yapılan yatırımlar içerisinde GES ve RES yatırımları en fazla yatırım yapılan yatırımlardır. Toplam yatırımın %56'sını GES'ler, %40'ını RES'ler oluşturmaktadır. GES yatırımları için 205 milyar ABD doları, RES yatırımları için 147 milyar ABD doları harcanmıştır (REN21, 2023).

Dünyada, 2027 yılına göre hazırlanan senaryoda kurulu güç kapasitenin %53'ünün YEK'e dayalı olacağı beklenmektedir. 2027 yılı için oluşturulan senaryoda YEK'e dayalı kurulu gücün %22,2'si GES, %14,4'ü RES, %14,1'i HES ve %2'si BES kaynaklı olacaktır. Hazırlanan senaryoda GES mevcut kapasitesinin üç katı kadar artacağı belirtilmiştir. Elektrikli araçların (EA) kullanım artışına bağlı olarak 2027 yılına kadar enerji talebinin %16'sının YEK'lerden karşılanacağı öngörülmektedir (IEA, 2022; IEA, 2023). AB Komisyonu, 2030 yılına kadar fosil yakıt tüketimi kaynaklı oluşan sera gazı emisyonu azaltımı için hedef belirlemiştir. 2030 yılına kadar fosil yakıt tüketimi kaynaklı oluşacak emisyon miktarını 1990 yılındaki sera gazı emisyon seviyesinde tutabilmek için emisyon artışından %40 sera gazı emisyon azaltımı için politika oluşturmuştur. Belirtilen hedef kapsamında, YEK payının %32 olması, enerji verimliliğinde ise %32,5 iyileştirme hedeflenmiştir (EEA, 2023; EUC, 2023).

2022 yılında Türkiye'de elektrik üretimi incelendiğinde 2021 yılına göre %2,5 azalarak 326,2 TWh olmuştur. Üretilen enerjinin %34,6'sı kömür, %22,2 doğalgaz, %20,6'sı hidrolik enerji, %10,8 rüzgar, %4,7'si güneş enerjisi, %3,3'ü jeotermal ve %3,7'si diğer kaynaklardan sağlanmıştır (ELDER, 2023).

Türkiye'de yıllık ortalama güneşlenme süresi 2.737 saat, toplam yıllık ışınım şiddeti ise 1.527 kWh/m<sup>2</sup> olarak hesaplanmıştır. Belirtilen ışınım ve güneşlenme süresine göre toplam güneş enerji potansiyeli 380 milyar kWh/yıl olarak belirlenmiştir (Aksungur ve diğ., 2013; EİGM, 2023). Türkiye'nin ortalama ışınım şiddeti ve güneşlenme süresi değerlendirildiğinde GES'lerden yararlanılarak enerji ithalatının önüne geçilebilir potansiyeli olduğu görülmektedir.

Türkiye'nin enerji politika belgelerinde, Türkiye'nin sahip olduğu zengin güneş enerjisi potansiyelinin değerlendirilmesi ile ilgili belirlenmiş politikalar ve politikalara uygun olarak belirlenmiş hedefler yer almaktadır. T.C. Enerji ve Tabii Kaynaklar Bakanlığı (ETKB) tarafından hazırlanan 2019-2023 Stratejik Planı kapsamında, 2023 yılına kadar YEK'lere dayalı elektrik kurulu gücünün %59'dan %65 seviyesine yükseltilmesi ile enerji arz güvenliği sağlanacağı belirtilmiştir. 2023 yılı için GES kurulu gücünün 10 GW kapasiteye ulaşacağı hedefler arasında yer almaktadır. Yenilenebilir Enerji Kaynak Alanları (YEKA) oluşturulması ile 2018 yılında %32,5 olan YEK'lerden elektrik üretimi payının 2023 yılında %38,8'e yükseltilmesi ve kurulacak olan yenilenebilir enerji santralleri ile 18 milyon ton emisyon azaltımı hedeflenmiştir (ETKB, 2018; SBB, 2019a).

T.C. Başkanlığı Strateji ve Bütçe Başkanlığı On Birinci Kalkınma Planı'nı hazırlamıştır. Hazırlanan planda kendi ihtiyacını karşılamak için YEK'e dayalı lisanssız GES uygulamalarının yaygınlaştırılması hedeflenmiştir. Yerli ekipman kullanımı desteklenerek, AR-GE, teknoloji transferi desteklenerek yeni yatırım modellerinin oluşturulması, YEK'lerin şebeke entegrasyonu ve YEK'lerin elektrik üretimindeki payının %32,5 seviyesinden 2023 yılında %38,8 seviyesine yükseltileceği belirtilmiştir (SBB, 2019b).

Türkiye Ulusal Enerji Planında 2022-2035 yılları arasında GES kapasitesinin 52,9 GW olacağı belirtilmiş ve 2035 yılı elektrik kurulu gücünün %64,7'sinin YEK ile sağlanması hedeflenmiştir (ETKB, 2023c).

Türkiye'de YEKA modeli 2016 yılında yatırım modeli olarak oluşturulmuştur. 2017 yılında YEKA-1 GES yarışması yapılmıştır. YEKA-1 GES yarışması sonucunda; minimum 500 MWp/yıl üretim kapasitesine sahip entegre fotovoltaik (FV) panel üretim fabrikası, 250 MWp/yıl hücre üretim kapasitesi ve 1.000 MWe kapasiteli Karapınar GES tesis kurulumu yapılacaktır. (Özcan, 2021). 2018 yılında YEKA-2 GES ihalesi ilanı açılmasına karşın iptal edilmiştir (EPDK, 2019b). YEKA-3 GES yarışması 36 şehirde 74 projeden 1.000 MW kapasite olacak şekilde planlanmış ve yarışma sonuçlanmıştır. YEKA-4 GES 32 ilde 59 projeden 1.000 MW yarışma ilanı açılmıştır. YEKA-5 GES için 1.500 MW yarışma Resmi Gazete'de yayımlanmasına karşın Bakanlık tarafından ileri bir tarihe ertelenmiştir (EPDK, 2019b; ETKB, 2021; ETKB, 2022; ETKB, 2023b).

Türkiye’de 25.329.833 adet konut bulunmaktadır (TÜİK, 2023). Türkiye’de konut sayılarının her geçen gün artması elektrik tüketiminin artışını da beraberinde getirmektedir. Meskenlerin elektrik ihtiyacını karşılamada GES’ler ön plana çıkmaktadır. Atıl durumda bulunan çatı ve cephelerde GES uygulamaları elektrik üretimini karşılayacak potansiyele sahiptir. Çatı ve cephelerde GES kurulumu meskenlerin enerji tüketimini aynı noktadan karşılamak açısından önemlidir. Türkiye’de LEÜ kapsamında, meskenlerin çatı ve cephelerinde 25 kW ve altı kurulu güç büyüklüklerinde GES uygulamalarının yapılması mümkündür. Çatı ve cephe GES uygulamalarının sayısının artırılması ve farkındalık yaratılması gereklidir.

Bu çalışmada Marmara Bölgesindeki Elektrik Dağıtım Şirketleri (EDAŞ)’lara 2018-2022 yılları içinde yapılan 25 kW ve altı çatı ve cephe GES proje başvurularının kabul ve ret durumları incelenmiştir. Bu çalışmanın yapılmasındaki amaç, 25 kW ve altı çatı ve cephe GES proje başvurularının ret gerekçelerini belirlemek ve bu ret gerekçelerini azaltacak öneriler sunmaktır. Bu başvuruların kabul sayısının artması, Türkiye’nin GES kurulu gücünü artıracak, YEK’lerin yaygınlaşmasını sağlayacaktır.

Çalışmanın ilk bölümü giriş bölümüdür. Çalışmanın ikinci bölümünde, Türkiye’de LEÜ, lisanssız elektrik kurulu gücünün yıllara göre gelişimi ve çatı ve cephe GES başvuruları incelenmiştir. Çalışmanın üçüncü bölümünde, Marmara Bölgesi içerisinde yer alan EDAŞ’lara yapılan 25 kW ve altı çatı ve cephe GES uygulamaları için başvuru sayısı, kabul ve ret gerekçeleri değerlendirilmiştir. Çalışmanın dördüncü bölümü Sonuç bölümüdür. Bu bölümde çalışmanın genel sonuçları verilmiştir. Çalışmanın son bölümü olan Tartışma ve Öneriler bölümünde, EDAŞ’lara yapılan başvuruların ret sayılarının azaltılmasına yönelik öneriler sunulmuştur.

## 2. Lisanssız Elektrik Üretimi

Elektrik Piyasası Kanunu (EPK) kapsamında üretim faaliyeti gerçekleştirebilmek için lisans alma koşuluyla elektrik piyasalarında faaliyet yürütebilmektedir (4628 sayılı Kanun, 2023). 4628 sayılı EPK’nın üçüncü maddesine dayanılarak LEÜ yönetmeliği (LEÜY) 03.12.2010 tarihli 27774 sayılı Resmi Gazete’de yayımlanarak yürürlüğe girmiştir (LEÜY, 2010). Yürürlüğe giren yönetmelik, azami 500 kW kurulu güce sahip YEK’e dayalı üretim tesisleri ve mikro kojenerasyon tesislerini kapsamıştır (4628 sayılı EPK, 2001).

5346 sayılı Yenilenebilir Enerji Kanunu içeriğinde yapılan değişiklikler ile LEÜY tekrardan hazırlanarak 21.07.2011 tarihli 28001 sayılı Resmi Gazete’de yayımlanmıştır (EPDK, 2011). Gerçekleştirilen bu düzenleme ile YEK’e dayalı üretim tesisleri için azami kurulu güç sınırı 500 kW’tan 1 MW’a yükseltilmiştir (EPDK, 2013). 4628 sayılı EPK 14.03.2013 tarihinde yürürlüğe giren 6446 sayılı EPK ile değiştirilmiştir. 6446 sayılı EPK, tüzel kişilerin piyasa faaliyetlerinde bulunan faaliyet izinleri ve kapsamaları Şekil 1’de verilmiştir.

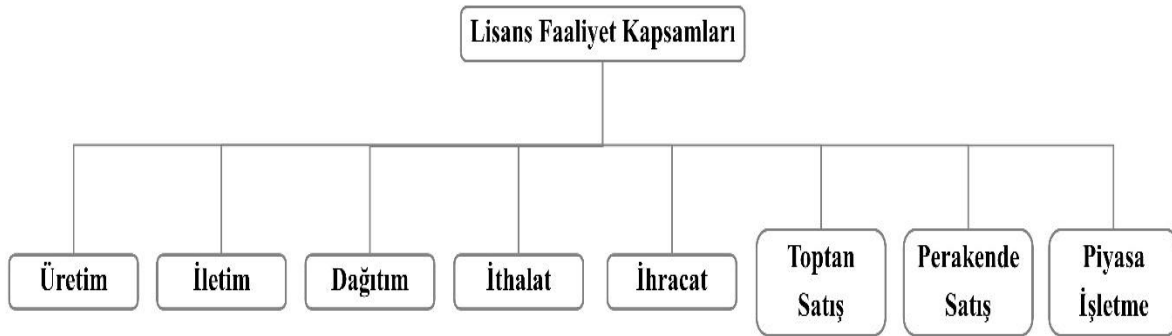

Şekil 1. Lisanslı olarak yapılabilecek faaliyetler (6446 sayılı Kanun, 2023)

6446 sayılı EPK, on dördüncü madde kapsamında elektrik piyasalarında lisans alma ve şirket kurma yükümlülüğüne ihtiyaç duymadan faaliyet yapılabilir (6446 sayılı Kanun, 2023).

LEÜ’nün temelini oluşturan GES’lerde yönetmelik oluşturulurken arazi tipi kurulumlar ağırlıklı olarak değerlendirilmiştir. 14.03.2013 tarihinde yürürlüğe giren 6446 sayılı EPK on dördüncü maddesi kapsamında YEK’e dayalı üretim tesisi kurulabilecek alanlar belirlenmiştir (6446 sayılı EPK, 2013). 6446 sayılı EPK

oluşturulduktan sonra, 03.12.2010 tarihli 27774 sayılı LEÜY kapsamı değiştirilmiştir. 02.10.2013 tarihinde 28783 sayılı Resmi Gazete’de kapsamı değiştirilen LEÜY ile YEK’e dayalı üretim tesislerinin sayısı artış göstermiştir (EPDK, 2013). 12.05.2019 tarihli 30772 sayılı Resmi Gazete’de LEÜY yapılan değişiklikler neticesinde arazi tipi GES’lerin kurulumu yerine aynı ölçüm noktasın üretim ve tüketim gerçekleştirebilmek için çatı tipi GES’ler yoğun olarak kurulmaktadır. LEÜY kapsamında iç ihtiyacı karşılamak için arazi kurulumları da yapılabilmektedir (EPDK, 2019a). Öz tüketim modeli ile lisanssız üretim tesisleri kendi iç tüketimini aynı noktadan karşılayarak kayıpların azalmasına ve şebeke yüklemelerinin önüne geçilmektedir.

EPDK, 18.01.2018 tarihinde tüketim tesisi ile aynı ölçüm noktasından bağlı ve güneş enerjisine dayalı çatı ve cephe uygulamaları kapsamındaki güneş enerjisi üretim tesisleri için lisanssız üretim başvuruları duyurusu yayımlamıştır. 18.03.2018 tarihli 30305 sayılı Resmi Gazetede yayımlanan duyuru, çatı ve cephe GES projelerinin azami kurulu gücü 10 kW kurulu güce sahip olacak şekilde sınırları belirlenmiştir. Yayımlanan duyuru kapsamında azami kurulu gücü 10 kW olan çatı ve cephe uygulamaları LEÜ içerisinde değerlendirilecek ve uygun bulunan projeler için çağrı mektubu verilecektir (7590 sayılı Karar, 2018). EPDK duyuru yayımladıktan sonra aynı yıl içerisinde TEDAŞ, LEÜY içeriğinde belirtilen 10 kW ve altı çatı ve cephe uygulamaları için tip proje ve bu kapsamdaki GES’lerde kullanılacak malzemenin kalite standartları ile tesiste mutlaka bulunması gereken tamamlayıcı donanımın neler olacağı belirtilmiştir (TEDAŞ, 2018). Eylül ayının başında 10 kW ve altındaki güçte kurularak çatı ve cephe tipi GES’lerin kuruluşunda TEDAŞ’ın proje onayı ve kabul işlemlerindeki yetkisi, bölgelerdeki elektrik dağıtım şirketlerine de verilmiştir (7590 sayılı Karar, 2018). EPDK’nın güneş enerjisine dayalı çatı ve cephe uygulamalarında aylık mahsuplaşmayla ilgili dağıtım tarifeleri 26.06.2019 tarihli 30813 sayılı Resmi Gazete’de yayımlanarak yürürlüğe girmiştir (EPDK, 2019a). Aylık mahsuplaşmanın belirlenmesi çatı ve cephe güneş enerji sistemlerinin yatırımlarını artıracak potansiyele sahiptir. Çatı ve cephe uygulamaları için 10 kW olan azami kurulu güç değeri, 11.08.2022 tarihli 31920 sayılı Resmi Gazete’de yayımlanan EPDK kararı ile 25 kW olacak şekilde değiştirilmiştir (EPDK, 2022).

LEÜ’de mevzuat gelişim süreci Şekil 2’de verilmiştir (5346 sayılı Kanun, 2005; EPDK, 2010; EPDK, 2011; 6446 sayılı Kanun, 2013; 7590 sayılı Karar, 2018; EPDK, 2019a; 1044 sayılı Karar, 2019; EPDK, 2022). Yenilenebilir enerji kullanımının yaygınlaşması için oluşturulan 5346 sayılı Kanun kaynak çeşitliliğinin önemini belirlemiştir. LEÜY kapsamında lisanssız yapılabilecek faaliyetler ve kapsamlar belirtilmiştir. Yıllar içerisinde yapılan değişiklikler gelişim süreçlerine pozitif katkı sağlamıştır.

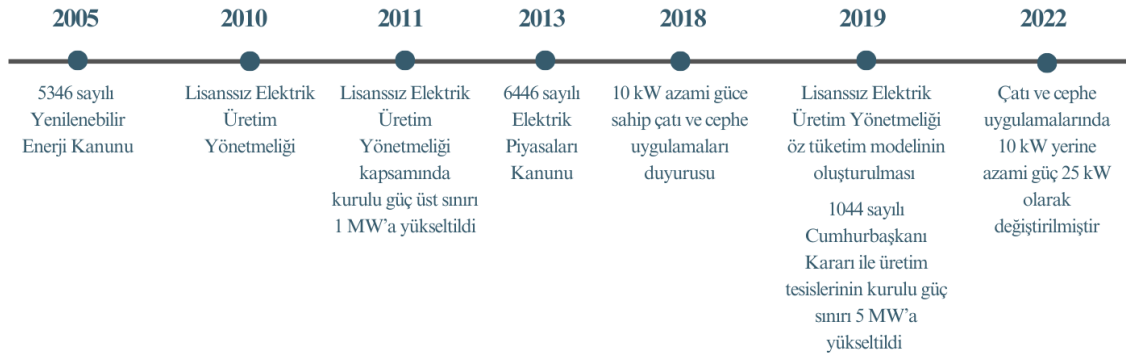

Şekil 2. Türkiye’de lisanssız elektrik üretim mevzuatının gelişim süreci

### 2.1. Lisanssız Kurulu Güç Gelişimi

Türkiye’nin 1990 yılındaki kurulu güç değeri 16.318 MW’dır. Kurulu güç değeri 2022 yılı sonu itibariyle 103.809 MW olmuştur. Türkiye’de elektrik kurulu gücünün yıllara göre değişimi Şekil 3’te verilmiştir.

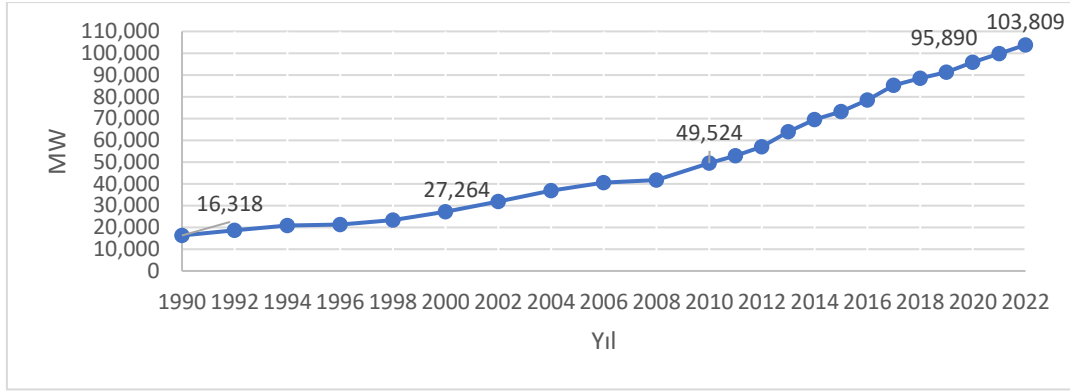

**Şekil 3.** Türkiye elektrik kurulu gücünün yıllara göre değişimi (TEİAŞ, 2022)

Kurulu güç değeri 2000 yılında 1990 yılına göre 1,67 kat artış göstererek 27.264 MW değerine ulaşmıştır (EMO, 2021; TEİAŞ, 2022). 2000 yılı ile 2010 yılları arasında mevcut kapasitenin %81,65'i kadar artış yaşanmış kurulu güç değeri 49.524 MW seviyesine ulaşmıştır. 2010 ile 2020 yılları arasında mevcut kapasitenin %93,62'si kadar artış görülmüş ve kurulu güç değeri 95.890 MW olmuştur. Türkiye'nin elektrik kurulu gücünde 2020 yılı ile 2022 yılları arasında mevcut kapasitenin %8,26'sı kadar artış görülmüş ve kurulu güç değeri 103.809 MW olmuştur (TEİAŞ, 2022). 1990 yılında kişi başı brüt elektrik enerjisi tüketimi 1,006 kWh iken bu değer 2020 yılında 3,61 kat artarak 3,661 kWh olmuştur (ÇŞİDB, 2023).

Türkiye'de LEÜY'de yapılan değişiklikler sonrası lisanssız santral başvuru sayıları artış göstermiştir. 2014 yılı sonunda GES'ler için çağrı mektubu almaya hak kazanan 2000 proje mevcut iken TEDAŞ'a proje kabulü yaptıran tesis 400 adet olarak belirlenmiştir. Geçici kabul kapsamında işletmeye alınan tesislerin toplam gücü 50 MW kapasiteyi aşmıştır (EPDK, 2023a). 2015- 2022 yılları arasındaki LEÜ tesislerinin kaynak bazlı dağılımı Tablo 1'de verilmiştir.

**Tablo 1.** Lisanssız kurulu gücün kaynaklara göre dağılımı (EPDK, 2023a)

Yıl	Güneş (Fotovoltaik)	Doğalgaz	Biyokütle	Rüzgar	Hidrolik	Güneş (Yoğunlaştırılmış)	Toplam Kurulu Güç (MW)
2015	292,91	36,47	21,44	6,02	0,5	1,7	359,04
Kaynağa Göre Dağılım (%)	81,58	10,16	5,97	1,68	0,14	0,47	
2016	939,19	51,85	36,42	13,75	5,78	1,22	1.048,21
Kaynağa Göre Dağılım (%)	89,6	4,95	3,47	1,31	0,55	0,12	
2017	2.978,84	85,88	66,72	32,2	8,69	1	3.173,32
Kaynağa Göre Dağılım (%)	93,87	2,71	2,1	1,01	0,27	0,03	
2018	5.016,99	153,04	79,18	51,95	8,91	0,5	5.310,57
Kaynağa Göre Dağılım (%)	94,47	2,88	1,49	0,98	0,17	0,01	
2019	5.825,46	328,66	75,67	70,83	8,65	-	6.309,27
Kaynağa Göre Dağılım (%)	92,33	5,21	1,2	1,12	0,14	-	
2020	6.257,61	402,67	83,71	70,83	8,65	-	6.823,47
Kaynağa Göre Dağılım (%)	91,71	5,9	1,23	1,04	0,13	-	
2021	6.907,78	463,05	89,11	73,08	13,98	-	7.546,99
Kaynağa Göre Dağılım (%)	91,53	6,14	1,18	0,97	0,19	-	
2022	7.956,64	490,7	89,91	81,58	16,42	-	8.635,25
Kaynağa Göre Dağılım (%)	92,14	5,68	1,04	0,94	0,19	-	



2022 yılı sonu itibariyle lisanssız santrallerin kurulu güç değeri, 2021 yılı kurulu güç değerine göre %14,42 oranında artarak 8.635,25 MW değerine ulaşmıştır. Lisanssız santraller içinde en yüksek kurulu güç değeri GES'lere aittir. GES'lerin toplam lisanssız santraller içindeki oranı %92,14'tür. Doğalgaz santralleri %5,68 ve BES'ler %1,04'lük orana sahiptirler (TEİAŞ, 2022). Toplam GES kurulu gücünün %84,42'lik kısmını lisanssız santraller, %15,58'lik kısmını lisanslı santraller oluşturmaktadır. Lisanslı ve lisanssız GES kurulu gücünün yıllara göre gelişimi Şekil 4'te verilmiştir (EPDK, 2023a).

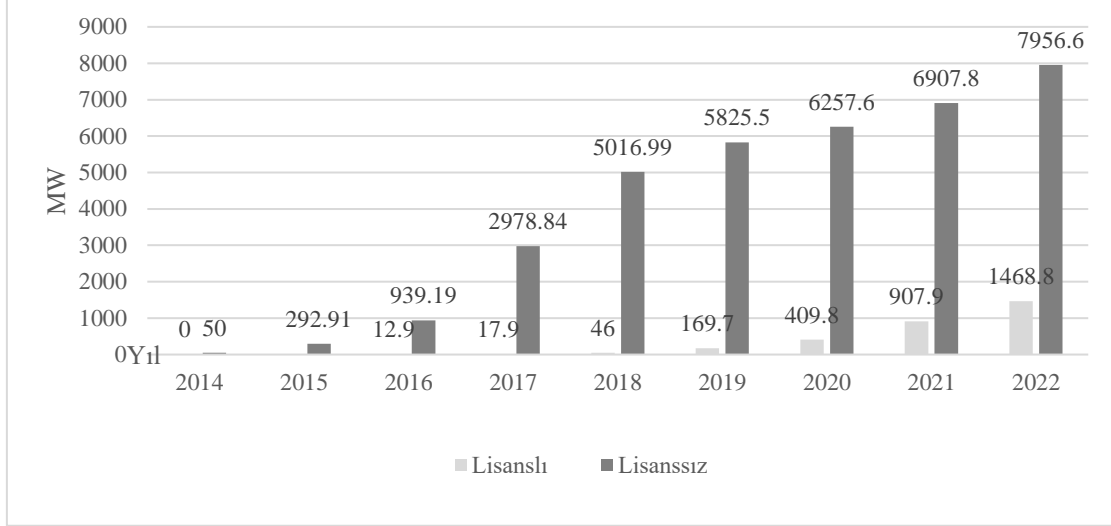

Şekil 4. Güneş enerji santrallerinin yıllara göre gelişimi (EPDK, 2023a)

Güneş enerjisi teknolojinin ilerlemesi ve ilk yatırım maliyetlerinin azalması ile GES yatırımları büyük bir ivme kazanmıştır. Güneş enerjisine yapılacak yatırımlar 2010 yılında en ucuz fosil yakıtlı santrale göre %710 daha pahalıyken, 2022 yılında en ucuz fosil yakıtlı santrale göre %29 daha ucuz olmuştur. 2022 yılında 2010 yılına göre toplam kurulum maliyetleri %83 azalmıştır (IRENA, 2022). Ekonomik açıdan maliyetlerin azalması yatırımları hızlandıracak potansiyele sahip iken LEÜY içeriği değiştirilerek santral kurulumlarını desteklemiştir (EPDK, 2023a). 2015-2022 yılları arasında lisanssız elektrik üretiminin kaynaklara göre dağılımı Tablo 2'de verilmiştir.

Tablo 2. Lisanssız Elektrik Üretimine Kaynaklara Göre Dağılımı (EPDK, 2023a)

Yıl	Güneş	Doğalgaz	Biyokütle	Rüzgar	Hidrolik	Toplam Üretim Miktarı (GWh)
2015	185,00	-	37,09	0,39	0,2014	222,69
Kaynak Dağılım (%)	83,07	-	16,66	0,18	0,09	
2016	1.031	-	92,13	8,27	6,12	1.137,87
Kaynak Dağılım (%)	90,64	-	8,1	0,76	0,54	
2017	2.836,55	0,11	138,66	36,80	19,43	3.031,56
Kaynak Dağılım (%)	93,57	0,01	4,57	1,21	0,64	
2018	7.860,58	-	205,90	111,54	34,75	8.212,77
Kaynak Dağılım (%)	95,71	-	2,51	1,36	0,42	
2019	9.425,97	-	255,49	113,56	34,44	9.829,45
Kaynak Dağılım (%)	95,90	-	2,6	1,16	0,34	
2020	10.825,50	-	273,45	119,47	27,07	11.245,48
Kaynak Dağılım (%)	96,27	-	2,43	1,06	0,24	
2021	11.741,52	44,28	147,30	244,88	38,89	12.216,87
Kaynak Dağılım (%)	96,11	0,36	2	1,21	0,32	
2022	12.362,12	23,5	131,94	149,55	71,37	12.738,48
Kaynak Dağılım (%)	97,05	0,18	1,04	1,17	0,56	

LEÜ kapsamında devreye alınan santrallerden 2015 yılı sonunda 222,69 GWh elektrik üretimi gerçekleşmiştir. Elektrik üretim miktarı 2015 yılına göre 57,20 kat artış göstererek, 2022 yılında 12.738,48 GWh değerine ulaşmıştır (EPDK, 2023a). Tablo 2’deki verilere göre; 2015 yılı sonunda toplam üretimin %83,07’lik kısmını GES’ler oluştururken 2022 yılı sonu toplam üretimin %97,05’lik kısmı GES’ler ile gerçekleştirilmiştir.

## 2.2.Çatı ve Cephe Güneş Enerjisi Santral Başvuruları

Türkiye genelinde faaliyet gösteren yirmi bir adet EDAŞ bulunmaktadır. EDAŞ’lar ve hizmet verdiği iller Tablo 3’te verilmiştir (TEDAŞ, 2023).

Türkiye geneli EDAŞ’ların toplam abone sayısı bir önceki yıla göre %2,65 artarak 2022 yılı sonunda 48.563.459 değerine ulaşmıştır. Marmara Bölgesi toplam abone sayısının %31,51’ine sahiptir. Türkiye’de 2022 yılında toplam elektrik tüketimi 253,62 TWh olarak hesaplanmıştır. Marmara Bölgesinin tüketim miktarı 90,41 TWh’dır. Marmara Bölgesi Türkiye’nin toplam elektrik tüketiminin %35,65’ini oluşturmaktadır (ELDER, 2023).

**Tablo 3.** Elektrik Dağıtım Şirketleri ve Hizmet Sağladığı İller (TEDAŞ, 2023)

Elektrik Dağıtım Şirketleri	Hizmet Verilen İller
ARAS EDAŞ	Ağrı, Ardahan, Bayburt, Erzincan, Erzurum, Iğdır, Kars
AKDENİZ EDAŞ	Antalya, Burdur, Isparta
AKEDAŞ	Adıyaman, Kahramanmaraş
AYDEM EDAŞ	Aydın, Denizli, Muğla
AYEDAŞ	İstanbul Anadolu Yakası
BAŞKENT EDAŞ	Ankara, Bartın, Çankırı, Karabük, Kastamonu, Kırıkkale, Zonguldak
BEDAŞ	İstanbul Avrupa Yakası
ÇAMLİBEL EDAŞ	Sivas, Tokat, Yozgat
ÇORUH EDAŞ	Artvin, Giresun, Gümüşhane, Rize, Trabzon
DİCLE EDAŞ	Batman, Diyarbakır, Mardin, Siirt, Şanlıurfa, Şırnak
FIRAT EDAŞ	Bingöl, Elazığ, Malatya, Tunceli
GEDİZ EDAŞ	İzmir, Manisa
KCETAŞ	Kayseri
MERAM EDAŞ	Aksaray, Karaman, Kırşehir, Konya, Nevşehir, Niğde
SAKARYA EDAŞ	Bolu, Düzce, Kocaeli, Sakarya
TRAKYA EDAŞ	Edirne, Kırklareli, Tekirdağ
TOROSLAR EDAŞ	Adana, Gaziantep, Hatay, Kilis, Mersin, Osmaniye
OSMANGAZİ EDAŞ	Afyonkarahisar, Bilecik, Eskişehir, Kütahya, Uşak
ULUDAĞ EDAŞ	Balıkesir, Bursa, Çanakkale, Yalova
VANGÖLÜ EDAŞ	Bitlis, Hakkari, Muş, Van
YEŞİLIRMAK EDAŞ	Amasya, Çorum, Samsun, Sinop, Ordu

EDAŞ’ların 2022 yılında dağıtım seviyesinden bağlı tüketicilere yapılan tahakkuk miktarlarında; dağıtım 192,62 TWh, iletim ile 61,00 TWh olarak ölçümlenmiştir. Toplam iletim ve dağıtım miktarının tüketici türüne göre dağılımında 108,37 TWh (%42,73) tüketim ile en büyük payı sanayi sektörü oluşturmaktadır. Kamu ve özel hizmetler sektörü 64,55 TWh (%25,45) tüketim, mesken kullanımlarında 61,87 TWh (%24,39), tarımsal faaliyetlerde 13,33 TWh (%3,72) ve aydınlatmada 5,50 TWh (%2,17)’lik tüketim gerçekleşmiştir (ETKB, 2023a).

Elektrik tüketim miktarlarının en fazla olduğu yer sanayidir. Elektrik tüketiminin sanayiden sonraki en yüksek payı sırasıyla; kamu, özel hizmetler sektörü ve meskenler oluşturmaktadır (ETKB, 2023a). Geleneksel elektrik üretim teknolojileri dışında, binaların enerji tüketimini karşılamada çatı ve cephe uygulamaları önemli bir

potansiyeye sahiptir. Çatı üstü ve cephede kurulan GES'ler, aynı tüketim noktasında üretim yaparak kayıpları azaltırken, şebeke yüklemesinin önüne geçmektedir.

25 kW ve altı çatı ve cephe GES uygulamalarında proje başvuru süreçleri EPDK tarafından belirlenmiştir. 25 kW'a kadar çatı ve cephe GES'ler için proje başvuru süreci Şekil 6'da verilmiştir.

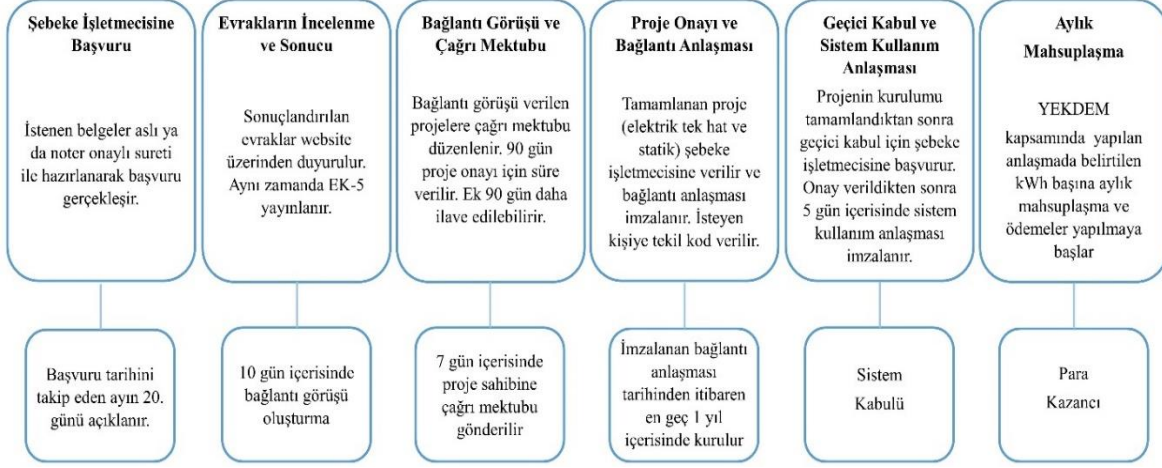

Şekil 6. 25 kW'a kadar çatı ve cephe güneş enerji santralleri için proje başvuru süreci

Başvuru sürecinde ilk aşama şebeke işletmesine başvuru yapılması aşamasıdır. Tüketim değeri 25 kW üst sınırına kadar olan ve öz tüketim modelinden yararlanmak için bağlantı başvurusu yapacak kişiler ilk olarak ilgili EDAŞ'a başvurmalıdır.

LEÜY on birinci maddesinin birinci bendinde 25kW'a kadar çatı ve cephe GES uygulamaları için başvuruda bulunulabileceği belirtilmektedir. EPDK, 25 kW'a kadar çatı ve cephe GES başvuruları için usul ve esaslarını belirlemiştir. Usul ve esaslar içerisinde gerekli bilgi ve belgelerin listesi (EK-1) verilmiştir (EPDK, 2023b). Başvuru için gerekli evrak listesi şöyledir:

1. Lisanssız üretim bağlantı başvuru formu (EK-4),
2. Gerçek kişiler için; aslıyla birlikte nüfus cüzdanı fotokopisi,
3. Tüzel kişiler için; tüzel kişiyi temsil ve ilzama yetkili şahıs veya şahısların yetki belgelerinin aslı ya da noter onaylı sureti ya da aslı ile sunulacak fotokopisi,
4. Üretim tesisinin kurulacağı alana ait tapu kaydı, kira sözleşmesi veya kullanım hakkını gösterir belge. Apartman veya siteler için üretim tesislerinin başvurusu için karar defterinde başvuru sahibine ilişkin güneş enerji tesisi kurabileceğine dair noter onaylı sureti,
5. Tüketim tesisinin tekil kodu,
6. Yapı ruhsatı veya inşaat ruhsatı yerine geçen belge,
7. Faaliyet yasağına ilişkin beyan (EK-2),
8. Yazılı ve CD sunumu şeklinde teknik değerlendirme formları (TDF). Kurulacak tesis için uygunluk belgeleri, gerekçe raporu, vaziyet planı, tek hat şeması, kısa devre hesaplamaları, topraklama projeleri ve proje statik raporu, coğrafi bilgi sistemi (CBS) uygunluğu, (Bağlantı görüşünden kabul sürecine kadar hazırlanması gereklidir),

Proje başvurularında evraklar uygun hazırlandığı durumda bağlantı görüşü verilerek üretim tesisi için çağrı mektubu oluşturulmaktadır. Başvuru esnasında dikkat edilecek hususlardan ilki tüketim ile üretim tesisleri aynı noktadan bağlanması zorunluluğudur. Farklı bağlantı noktaları için yapılan başvurular değerlendirmeye alınmamaktadır. Üretim tesisi için belirlenen kurulu güç, tüketim tesisinin bağlantı anlaşmasında belirtilen sözleşme gücünden fazla olmamalıdır. Sözleşme gücünü aştığı durumda proje reddedilir. Üretim tesisi ile tüketim tesisinde tüketim birleştirme yapılamamaktadır. Her tüketim tesisi için tek başvuru yapılması gereklidir. Farklı bir lisanssız üretim tesisi ile ilişkilendirilen tüketim aboneliği ile tekrardan başvuru yapılamaz (EPDK, 2023b).

EDAŞ'lara yapılan başvurularda eksik evrak beyanı olduğu durumda projeler değerlendirmeye alınmadan ret verilir. EDAŞ'lara ait transformatöre bağlanması durumunda transformatör gücünün %50'sine kadar başvuru yapılabileceği belirtilmiştir. Transformatörün başvuru sahibine ait olması durumunda azami 25 kW'a kadar başvuruda bulunabilir. Aynı dağıtım transformatörüne birden çok başvuru yapılması durumunda ise son 1 yıl içerisindeki tüketim miktarları değerlendirilerek tüketimi fazla olan abonenin başvurusu kabul edilir. 1 yıllık kullanımı olmayan aboneler için mevcut aylık tüketimin ortalaması belirlenerek yıllık tüketim değeri hesaplanır. İnşa halindeki tesisler için yapılan başvurularda 1 aylık tüketimi bulunmadığından tüketim değerlendirmesi yapılamamaktadır. Başvuru esnasındaki sözleşme gücü ve tüketim miktarı belirlenmediğinden aynı abone grubundaki benzer aboneliklerin tüketim miktarına göre belirlenmektedir. Abone tüketim durumuna göre aynı kriterleri sağlayan başvurular içinde başvuru tarihi esas alınarak kabul edilmektedir (EPDK, 2023b).

Proje başvuru evraklarının değerlendirme sonuçları, başvuru tarihini takip eden ayın 20. günü açıklanmaktadır. Proje başvuruları uygun görülen abonelere olumlu bağlantı görüşü oluşturularak çağrı mektubu hazırlanmaktadır. Çağrı mektubu isteğe bağlı olarak kargo ile ya da müşteriye elden teslim edilebilmektedir. Başvuruların değerlendirme sonuçları bağlı bulunan şebeke işletmecisinin internet adresi üzerinden paylaşılır. Başvuru değerlendirme sonuçları uygunsuz bulunan proje başvuru sahiplerine internet adresi üzerinde paylaşılmasının yanında yazılı bildirim yapılır. Başvuru süreci olumlu sonuçlanan ve çağrı mektubu düzenlenen yatırımcılara projelerin onaylatılması ve şebeke işletmecisine sunulması, üretim tesisinin kurulumu için 90 gün süre tanınmaktadır. 90 gün içerisinde proje onayı ve süreci tamamlanamayan projeler için talep edilmesi durumunda 90 gün ilave süre verilebilmektedir.

Proje onayına ilişkin belge ve onaylı projenin sunulmaması halinde çağrı mektubu geçersiz sayılmaktadır. 90 veya 180 gün verilen süre içerisinde elektrik tek hat şeması ve statik proje onayları şebeke işletmecisine sunulur ve 15 gün içerisinde bağlantı anlaşması imzalanır. Bağlantı anlaşması imzalandıktan sonra en geç 1 yıl içerisinde projenin tamamlanması gereklidir. 1 yıl içerisinde tamamlanmadığı durumda bağlantı anlaşması hükümsüz olmaktadır. 1 yıl içerisinde tamamlanan projelerin kabulü için şebeke işletmecisine geçici kabul için başvuruda bulunulması gereklidir. Devreye alma işlemini ilgili EDAŞ tarafından gerçekleştirilmektedir. Üretim tesisi devreye alındıktan sonra üç gün içerisinde şebeke işletmecisi ile sistem kullanım anlaşması imzalanır.

Sistem kullanım anlaşması imzalanan projelerde ihtiyaç fazlası enerji çift yönlü sayaç ile şebekeye aktarılır. Üretim ve tüketim miktarı çift yönlü sayaç ile belirlenir. Üretim miktarının fazla olması durumunda YEKDEM kapsamında yapılan anlaşmaya göre aylık olarak mahsuplaşma gerçekleştirilir.

Bağlantı anlaşmasındaki sözleşme gücü 3 kW'a kadar olan projeler için yapılan başvurularda şebeke işletmecisi doğrudan bağlantı görüşü oluşturup çağrı mektubu düzenleyebilmektedir (EPDK, 2023b).

"25 kW'a Kadar Güneş Enerjisine Dayalı Elektrik Üretim Tesisleri için Usul ve Esaslar "Ek-1'de sıralanan bilgi ve belgeler listesi esas alınarak, EDAŞ'lar tarafından, başvuru yapanlara belirtilen ret gerekçeleri incelenmiş (AYEDAŞ, 2023; BEDAŞ, 2023; SEDAŞ, 2023; TREDAS, 2023; UEDAŞ, 2023) ve listelenmiştir. Bu gerekçeler ve ret gerekçelerinin açıklamaları Tablo 4'te verilmiştir.

**Tablo 4.** EDAŞ başvuruları ret gerekçeleri ve açıklamaları

Ret gerekçeleri	Açıklama
Tekil Kod / Abone Grubu Bilgisi Hatalı	EDAŞ'lar tarafından tüketim noktası için belirtilen ve Piyasa Yönetim Sistemi'ne kayıt için kullanılan kayıt koduna tekil kod denilmektedir. Başvurulan projelerde tekil kod yazılmayıp eksik olduğu görülmüştür. Abone grubu bilgisi, elektrik aboneliği esnasında kullanım şekli ve amacına göre farklı fiyatlardan faturalandırılması için yapılan gruplandırmayı ifade etmektedir. 25 kW çatı cephe uygulamalarında alçak gerilim (AG) olması gereken abone grubu bilgisi yanlış girildiği görülmüştür.
EK-1	25 kW'a Kadar Güneş Enerjisine Dayalı Elektrik Üretim Tesisleri için Usul ve Esaslar'da bulunan Ek-1'dir. 25 kW azami kurulu güce sahip çatı ve cephe uygulamalarında başvuru için gerekli evrakların belirtildiği listedir.
EK-2	25 kW'a Kadar Güneş Enerjisine Dayalı Elektrik Üretim Tesisleri için Usul ve Esaslar'da bulunan Ek-2'dir. Faaliyet Yasağına İlişkin Beyanı ifade etmektedir.
EK-4	25 kW'a Kadar Güneş Enerjisine Dayalı Elektrik Üretim Tesisleri için Usul ve Esaslar'da bulunan Ek-4'tür. Lisanssız Üretim Bağlantı Başvuru Formu ifade etmektedir.
Tapu / Muvafakatname	Proje başvurusu tapu sahibi ise tapu ile beraberinde noter onaylı sureti talep edilmektedir. Belirtilen tapunun formatının uygun olmadığı, belirtilen tapunun kurulacak üretim tesisi adresinden farklı olduğu görülen projeler için belirtilmiştir. Üretim tesisi kurulacak bölge için tapunun hisseli olması durumunda diğer hissedarlardan muvafakatname alınması gereklidir. Kiracı tarafından yapılan başvurularda da mülk sahibinden muvafakatname alınması gereklidir. Parsel bilgileri uyumsuz olan başvurular bu kısımda belirtilmiştir.
2 Yıllık Kira Sözleşmesi, Kira Kontratı, Kullanım Hakkını Gösterir Belge	Proje başvurusunu kiracı ya da tapu sahibinin farklı olması durumunda 2 yıllık kira sözleşmesi, kira kontratı ya da kullanım hakkını gösterir belgenin başvuru evrakları içerisinde yer almadığı görülmüştür.
Siteler, apartmanlar için karar defterindeki kararın noter onaylı sureti	Toplu mesken alanlarında yapılacak başvurularda karar defterindeki kararın noter onaylı sureti başvuru dosyaları içerisinde yer alması gereklidir.
Gerçek kişiler için yapılan başvurularda	Kimlik suretinin aslıyla birlikte sunulması gereklidir.
Tüzel kişiler tarafından yapılan başvurularda	Yetki belgesi aslı veya noter onaylı suretleri veya aslıyla birlikte sunulacak fotokopilerinin başvuru dosyasında yer alması gereklidir.
Başvuru evrakları için imza beyanı veya sirküleri	Başvuru dosyasında hazır vaziyette olması gereklidir

Tüzel kişilerin başvurularında vekaletname veya vekil kişi imza beyanı veya şirketin imza beyanı sirküleri	Evrak beyanı esnasında imza sirkülerinin olmadığı görülmüştür. Başvuru dosyasında eksiksiz yer alması gereklidir.
Abonelik olduğunu gösterir belge, ruhsat durumları ve abonelik aşamaları	Abonelik olduğunu gösterir belgenin eksik olması, ruhsat çıkarılmadan yapılan başvuruları, proje başvurularında abonelik bilgilerinin başvuru dosyasında yer almadığı görülmüştür.
Tesisin kurulması planlanan adres ile projede yer alan adres farklı (Tesisat sahibi farklı)	Adreslerin farklı olmasından kaynaklı iptal edilen projeleri ifade etmektedir. Ayrıca tesisat sahibi farklı gözükken proje değerlendirme sonuçları da bu kısma dahil edilmiştir.
Kurulması planlanan üretim tesisi kurulu gücü sözleşme gücünden fazla olan başvurular	25 kW çatı ve cephe uygulama usul ve esaslarında planlanan üretim tesisi kurulu gücü sözleşme gücünden fazla olamayacağı usul ve esaslarda belirtilmektedir.
Bağlantı anlaşması süresi doldu	Başvuruları olumlu sonuçlanan projelerin 90 ve 180 güne uzatılan bağlantı anlaşması süresinin dolmasından kaynaklı projeleri belirtmektedir.
Tüketim birleştirme	Başvuru usul ve esaslarında tüketim birleştirme yapılamayacağı belirtilmiştir.
Bir tüketim tesisi için birden fazla başvuru yapıldığı görülmüştür	Aynı projede birden fazla başvuru yapılamaz.
Proje reddedilme / eksik (hatalı) evrak ve talep kaynaklı proje iptali	Projenin gerekçesi belirtilmeden reddedilen projeleri ve talep kaynaklı projelerin iptal edilmesini ifade etmektedir.
Sözleşme gücü ve başvuru türü belirtilmemiştir	Başvurularda sözleşme gücü ve başvuru türü belirtilmediğini ifade etmektedir.
EİGM TDF formlarının yazılı ve CD sunumunda eksik bilgiler	Proje başvurusunda CD sunumunda tesis adı farklı belirtilmiş.
Tek hat şemasının sunulmaması	Başvurusu yapılan projede tek hat şeması sunulmadığını belirtmektedir.
Usul ve Esaslar 6. Madde 1. Fıkra	Proje başvurularında eksik evraklardan kaynaklı olumsuz sonuçların, güneş enerji destekli 25 kW çatı ve cephe uygulama esaslarının başvuru usul ve esaslarında belirtilen altıncı madde birinci fıkrası gereğince reddedildiği belirtilmiştir.

### 3.Marmara Bölgesindeki Çatı ve Cephe Güneş Enerjisi Santrali Proje Başvuruları

Marmara Bölgesinde beş EDAŞ bölgenin elektrik ihtiyacını karşılamaktadır. Marmara Bölgesinde İstanbul Anadolu Yakası Elektrik Dağıtım Şirketi (AYEDAŞ), Boğaziçi Elektrik Dağıtım Şirketi (BEDAŞ), Sakarya Elektrik Dağıtım Şirketi (SEDAŞ), Trakya Elektrik Dağıtım Şirketi (TREDAŞ) ve Uludağ Elektrik Dağıtım Şirketi (UEDAŞ) firmaları faaliyet göstermektedir (AYEDAŞ, 2023; BEDAŞ, 2023; SEDAŞ, 2023; TREDAŞ, 2023; UEDAŞ, 2023).

Marmara Bölgesinde EDAŞ'lara yapılan başvuru sayıları Tablo 5'te verilmiştir.

**Tablo 5.** Marmara Bölgesinde EDAŞ'lara yapılan başvuru sayıları (AYEDAŞ, 2023; BEDAŞ, 2023; SEDAŞ, 2023; TREDAS, 2023; UEDAŞ, 2023).

Yıl		Yapılan Başvuru Sayısı					Toplam Başvuru Sayısı
		AYEDAŞ	BEDAŞ	SEDAŞ	TREDAS	UEDAŞ	
2018	Kabul	5	38	8	2	15	68
	Ret	8	1	4	2	18	33
2019	Kabul	11	35	-	3	31	80
	Ret	7	6	-	1	16	30
2020	Kabul	19	82	50	2	28	181
	Ret	21	3	21	1	49	95
2021	Kabul	14	100	31	42	77	264
	Ret	26	6	20	41	33	126
2022	Kabul	53	164	211	14	209	651
	Ret	56	25	44	18	56	199
2018-2022	Toplam	220	460	389	126	532	1727

Marmara Bölgesinde, 2018 yılında toplam 101 adet proje başvurusu yapılmıştır. Yapılan başvuruların %67,33'ü kabul, %32,67'si reddedilmiştir. 2019 yılında toplam 110 proje başvurusu yapılmıştır. 2019 yılında SEDAŞ'a yapılan başvurulara internet üzerinden erişim sağlanamamıştır (SEDAŞ, 2023). SEDAŞ haricindeki başvuruların %72,73'ü kabul, %27,27'si reddedilmiştir. 2020 yılında toplam 276 proje başvurusu yapılmıştır. Proje başvurularının %65,58'i kabul, %34,42'si reddedilmiştir. 2021 yılında toplam 390 proje başvurusu yapılmıştır. 2021 yılında gerçekleşen başvuruların %67,69'u kabul, %32,31'i reddedilmiştir. 2022 yılında toplam 850 başvuru yapılmıştır. 2022 yılında gerçekleşen başvuruların %76,59'u kabul, %23,41'i reddedilmiştir. Marmara Bölgesinde 2018-2022 yılları arasında toplam 1727 proje başvurusu yapılmıştır. Gerçekleşen başvuruların %72,03'ü kabul, %27,97'si reddedilmiştir (AYEDAŞ, 2023; BEDAŞ, 2023; SEDAŞ, 2023; TREDAS, 2023; UEDAŞ, 2023).

Tablo 5'te verilen ret gerekçeleri incelendiğinde, reddedilen bazı projelerde bir gerekçe belirtildiği, bazı projelerde ise birden çok gerekçenin ilgili EDAŞ tarafında belirtildiği görülmüştür. Proje değerlendirmesinde yer alan gerekçeler ayrı ayrı hata gibi kabul edilmiş ve değerlendirilmiştir.

AYEDAŞ'a yapılan başvuruların ret gerekçeleri ile ilgili detaylar Tablo 6'da verilmiştir (AYEDAŞ, 2023).

**Tablo 6.** AYEDAŞ firmasına yapılan proje başvuruların ret gerekçeleri

AYEDAŞ Firması Ret Gerekçeleri	Ret Gerekçelerinin Sayısı	Yüzdelik Hata (%)
Tekil Kod / abone grubu bilgisi hatalı	-	-
EK-1	1	0,85
EK-2	4	3,39
EK-4	2	1,70
Tapu / muvafakatname	6	5,09
2 yıllık kira sözleşmesi, kira kontratı, kullanım hakkını gösterir belge	3	2,54
Siteler, apartmanlar için karar defterindeki kararın noter onaylı sureti	2	1,70
Başvuru sahibi gerçek kişi ise kimlik sureti aslıyla birlikte sunulmalı	-	-
Şirketler tarafından yapılan başvurularda, yetki belgesi aslı veya onaylı suretleri veya aslıyla birlikte sunulacak fotokopileri	3	2,54
Başvuru evrakları için imza beyanı / sirküsü	-	-
Vekaletname / Vekil kişi / Şirketin İmza Beyanı / sirküsü	3	2,54
Abonelik olduğunu gösterir belge, ruhsat durumları, abonelik aşamaları	1	0,85
Tesisin kurulması planlanan adres ile projede yer alan adres farklı (tesisat sahibi farklı)	5	4,24
Kurulması planlanan üretim tesisi kurulu gücü sözleşme gücünden fazla olan başvurular	17	14,41
Bağlantı anlaşması süresi doldu	69	58,48
Proje reddedilme / eksik (hatalı) evrak ve talep kaynaklı proje iptali	6	5,09
Tüketim birleştirme yapılamaz	1	0,85
Bir tüketim tesisi için birden fazla başvuru yapıldığı görülmüştür	-	-
Sözleşme gücü ve başvuru türü belirtilmemiştir	-	-
EİGM TDF formlarının yazılı ve CD sunumunda tesis adı farklı belirtilmiş. Başvuru güç, abone türü bilgileri eksik	-	-
Tek Hat şeması sunulmamış	-	-
Usul ve Esaslar 6. Madde 1. Fıkra	6	5,09

AYEDAŞ'a, 2018 yılında toplam 13 adet başvuru yapılmıştır. 2018 yılında yapılan başvuruların % 38,46'sı kabul edilmiştir. Gerçekleştirilen başvuruların %61,53'ü reddedilmiştir. 2019 yılında toplam 18 adet başvuru yapılmıştır. 2019 yılında yapılan başvuruların % 61,11'i kabul, %38,89'u reddedilmiştir. 2020 yılında toplam 40 adet başvuru yapılmıştır. 2020 yılında yapılan başvuruların % 47,5'i kabul, %52,5'i reddedilmiştir. 2021 yılında toplam 40 adet başvuru yapılmıştır. 2021 yılında yapılan başvuruların % 35'i kabul, %65'i reddedilmiştir. 2022 yılında toplam 109 adet başvuru yapılmıştır. 2022 yılında yapılan başvuruların % 48,63'ü kabul, %51,37'si reddedilmiştir. 2018-2022 yılları arasında toplam 220 proje başvurusunun %46,36'sı kabul, %53,63'ü ise reddedilmiştir (AYEDAŞ, 2023).

Tablo 6'da verilen proje ret gerekçelerine göre; en fazla ret gerekçesinin bağlantı anlaşmasının süresinin dolması nedeniyle olduğu görülmüştür. Proje başvurularında bağlantı anlaşmasının süresi dolan toplam 69 proje iptal edilmiştir. Bağlantı anlaşmasının süresinin dolması toplam hata miktarının %58,48'ini oluşturmuştur. Proje başvuru sonuçlarında belirlenen bir diğer ret gerekçesi ise kurulması planlanan üretim tesisi kurulu gücünün sözleşme gücünden fazla olmasıdır. Hata miktarının %14,407'sini oluşturan bu sorun 17 projenin reddedilmesine sebep olmuştur (AYEDAŞ, 2023).



BEDAŞ'a yapılan başvuruların ret gerekçeleri ile ilgili detaylar Tablo 7'de verilmiştir (BEDAŞ, 2023).

**Tablo 7.** BEDAŞ firmasına yapılan proje başvuruların ret gerekçeleri

BEDAŞ Firması Ret Gerekçeleri	Ret Gerekçelerinin Sayısı	Yüzdellik Hata (%)
Tekil Kod / abone grubu bilgisi hatalı	-	-
EK-1	-	-
EK-2	-	-
EK-4	-	-
Tapu / muvafakatname	6	14,634
2 yıllık kira sözleşmesi, kira kontratı, kullanım hakkını gösterir belge	6	14,634
Siteler, apartmanlar için karar defterindeki kararın noter onaylı sureti	2	4,878
Başvuru sahibi gerçek kişi ise kimlik sureti aslıyla birlikte sunulmalı	-	-
Şirketler tarafından yapılan başvurularda, yetki belgesi aslı veya onaylı suretleri veya aslıyla birlikte sunulacak fotokopileri	-	-
Başvuru evrakları için imza beyanı / sirküsü	-	-
Vekaletname / Vekil kişi / Şirketin İmza Beyanı / sirküsü	6	14,634
Abonelik olduğunu gösterir belge, ruhsat durumları, abonelik aşamaları	6	14,634
Tesisin kurulması planlanan adres ile projede yer alan adres farklı (tesisat sahibi farklı)	3	7,317
Kurulması planlanan üretim tesisi kurulu gücü sözleşme gücünden fazla olan başvurular	16	39,024
Bağlantı anlaşması süresi doldu	-	-
Proje reddedilme / eksik (hatalı) evrak ve talep kaynaklı proje iptali	1	2,439
Tüketim birleştirme yapılamaz	1	2,439
Bir tüketim tesisi için birden fazla başvuru yapıldığı görülmüştür	-	-
Sözleşme gücü ve başvuru türü belirtilmemiştir	-	-
EİGM TDF formlarının yazılı ve CD sunumunda tesis adı farklı belirtilmiş. Başvuru güç, abone türü bilgileri eksik	-	-
Tek Hat şeması sunulmamış	-	-
Usul ve Esaslar 6. Madde 1. Fıkra	6	14,634

BEDAŞ'a, 2018 yılında toplam 39 adet başvuru yapılmıştır. 2018 yılında yapılan başvuruların % 97,44'ü kabul, %2,56'ü reddedilmiştir. 2019 yılında toplam 41 adet başvuru yapılmıştır. 2019 yılında yapılan başvuruların % 85,37'si kabul, %14,63'ü reddedilmiştir. 2020 yılında toplam 85 adet başvuru yapılmıştır. 2020 yılında yapılan başvuruların % 96,42'si kabul, %3,53'ü reddedilmiştir. 2021 yılında toplam 106 adet başvuru yapılmıştır. 2021 yılında yapılan başvuruların % 94,34'ü kabul, %5,66'sı reddedilmiştir. 2022 yılında toplam 189 adet başvuru yapılmıştır. 2022 yılında yapılan başvuruların % 86,77'si kabul, %13,23'ü reddedilmiştir. BEDAŞ'a 2018-2022 yılları arasında yapılan toplam 460 proje başvurusunun %91,09'u kabul, %8,91'i ise reddedilmiştir. (BEDAŞ, 2023).

Tablo 7'de verilen ret gerekçeleri incelendiğinde; en yüksek ret gerekçesi, kurulması planlanan üretim tesisi kurulu gücü sözleşme gücü üzerinde olmaması gereklidir. Başvurularda üretim tesisi kurulu gücü üzerinde başvuru yapılmasından kaynaklanmıştır. İlgili uygunsuzluk %39,02 oran ile 16 projenin reddedilmesine sebep olmuştur. Diğer hatalarda aynı oranda %14,634 ile tapu/muvafakatname, vekaletname, imza beyanı sirküsü abonelik olduğunu gösterir belge ve ruhsat durumları oluşturmuştur (BEDAŞ, 2023).

SEDAŞ'a yapılan başvuruların ret gerekçeleri ile ilgili detaylar Tablo 8'de verilmiştir (SEDAŞ, 2023)

**Tablo 8.** SEDAŞ firmasına yapılan proje başvurularının ret gerekçeleri

SEDAŞ Firması Ret Gerekçeleri	Ret Gerekçelerinin Sayısı	Yüzdelik Hata (%)
Tekil Kod / abone grubu bilgisi hatalı	15	16,854
EK-1	-	-
EK-2	31	34,831
EK-4	28	31,46
Tapu / muvafakatname	36	40,45
2 yıllık kira sözleşmesi, kira kontratı, kullanım hakkını gösterir belge	22	24,72
Siteler, apartmanlar için karar defterindeki kararın noter onaylı sureti	23	25,843
Başvuru sahibi gerçek kişi ise kimlik sureti aslıyla birlikte sunulmalı	2	2,247
Şirketler tarafından yapılan başvurularda, yetki belgesi aslı veya onaylı suretleri veya aslıyla birlikte sunulacak fotokopileri	34	38,202
Başvuru evrakları için imza beyanı / sirküsü	7	7,865
Vekaletname / Vekil kişi / Şirketin İmza Beyanı / sirküsü	5	5,62
Abonelik olduğunu gösterir belge, ruhsat durumları, abonelik aşamaları	3	3,37
Tesisin kurulması planlanan adres ile projede yer alan adres farklı (tesisat sahibi farklı)	3	3,37
Kurulması planlanan üretim tesisi kurulu gücü sözleşme gücünden fazla olan başvurular	22	24,719
Bağlantı anlaşması süresi doldu	3	3,37
Proje reddedilme / eksik (hatalı) evrak ve talep kaynaklı proje iptali	-	-
Tüketim birleştirme yapılamaz	-	-
Bir tüketim tesisi için birden fazla başvuru yapıldığı görülmüştür	2	2,247
Sözleşme gücü ve başvuru türü belirtilmemiştir	-	-
EİGM TDF formlarının yazılı ve CD sunumunda tesis adı farklı belirtilmiş. Başvuru güç, abone türü bilgileri eksik	-	-
Tek Hat şeması sunulmamış	-	-
Usul ve Esaslar 6. Madde 1. Fıkra	1	1,123

SEDAŞ'a, 2018 yılında toplam 13 adet başvuru yapılmıştır. 2018 yılında yapılan başvuruların % 66,67'si kabul, %33,33'ü ise reddedilmiştir. 2019 yılında SEDAŞ'a yapılan başvurulara internet sitesi üzerinde erişim sağlanamamaktadır. 2020 yılında toplam 71 adet başvuru yapılmıştır. 2020 yılında yapılan başvuruların % 70,42'si kabul, %29,58'i ise reddedilmiştir. 2021 yılında toplam 51 adet başvuru yapılmıştır. 2021 yılında yapılan başvuruların % 60,78'i kabul, %39,22'si ise reddedilmiştir. 2022 yılında toplam 255 adet başvuru yapılmıştır. 2022 yılında yapılan başvuruların % 82,75'i kabul, %17,25'i ise reddedilmiştir. SEDAŞ'a 2018-2022 yılları arasında yapılan toplam 389 proje başvurusunun %77,12'si kabul, %22,88'si ise reddedilmiştir (SEDAŞ, 2023).

Tablo 8'de verilen başvuru ve ret gerekçelerinde en yüksek gerekçe tapu/muvafakatname kaynaklıdır. İlgili uygunsuzluk %40,45 oran ile 36 projenin reddedilmesine sebep olmuştur. Başvurularda en çok yapılan bir diğer hata %38,20 ile şirketlerin yetki belgelerinde olan eksikliklerden kaynaklı olmuştur. Belirtilen hatadan kaynaklı 34 proje reddedilmiştir (SEDAŞ, 2023).

TREDAŞ'a yapılan başvuruların ret gerekçeleri ile ilgili detaylar Tablo 9'da verilmiştir (TREDAŞ, 2023).

**Tablo 9.** TREDAŞ firmasına yapılan proje başvuruların ret gerekçeleri

TREDAŞ Firması Ret Gerekçeleri	Ret Gerekçelerinin Sayısı	Yüzdellik Hata (%)
Tekil Kod / abone grubu bilgisi hatalı	1	1,587
EK-1	1	1,587
EK-2	39	61,904
EK-4	4	6,349
Tapu / muvafakatname	9	14,285
2 yıllık kira sözleşmesi, kira kontratı, kullanım hakkını gösterir belge	1	1,587
Siteler, apartmanlar için karar defterindeki kararın noter onaylı sureti	-	-
Başvuru sahibi gerçek kişi ise kimlik sureti aslıyla birlikte sunulmalı	-	-
Şirketler tarafından yapılan başvurularda, yetki belgesi aslı veya onaylı suretleri veya aslıyla birlikte sunulacak fotokopileri	-	-
Başvuru evrakları için imza beyanı / sirküsü	-	-
Vekaletname / Vekil kişi / Şirketin İmza Beyanı / sirküsü	2	3,174
Abonelik olduğunu gösterir belge, ruhsat durumları, abonelik aşamaları	3	4,762
Tesisin kurulması planlanan adres ile projede yer alan adres farklı (tesisat sahibi farklı)	-	-
Kurulması planlanan üretim tesisi kurulu gücü sözleşme gücünden fazla olan başvurular	5	7,936
Bağlantı anlaşması süresi doldu	-	-
Proje reddedilme / eksik (hatalı) evrak ve talep kaynaklı proje iptali	2	3,174
Tüketim birleştirme yapılamaz	-	-
Bir tüketim tesisi için birden fazla başvuru yapıldığı görülmüştür	-	-
Sözleşme gücü ve başvuru türü belirtilmemiştir	1	1,587
EİGM TDF formlarının yazılı ve CD sunumunda tesis adı farklı belirtilmiş. Başvuru gücü, abone türü bilgileri eksik	5	7,936
Tek Hat şeması sunulmamış	2	3,174
Usul ve Esaslar 6. Madde 1. Fıkra	-	-

TREDAŞ'a 2018 yılında toplam 4 adet başvuru yapılmıştır. 2018 yılında yapılan başvuruların %50'si kabul, %50'si reddedilmiştir. 2019 yılında toplam 4 adet başvuru yapılmıştır. 2019 yılında yapılan başvuruların %75'i kabul, %25'i reddedilmiştir. 2020 yılında toplam 3 adet başvuru yapılmıştır. 2020 yılında yapılan başvuruların %66,67'si kabul, %33,33'ü ise reddedilmiştir. 2021 yılında toplam 51 adet başvuru yapılmıştır. 2021 yılında yapılan başvuruların %50,60'ı kabul, %49,40'ı ise reddedilmiştir. 2022 yılında toplam 255 adet başvuru yapılmıştır. 2022 yılında yapılan başvuruların %43,75'i kabul, %56,25'si ise reddedilmiştir. TREDAŞ firmasına 2018-2022 yılları arasında yapılan toplam 126 proje başvurusunun %50'si kabul, %50'si ise reddedilmiştir (TREDAŞ, 2023).

Tablo 9'te verilen, TREDAŞ ret gerekçeleri incelendiğinde; en yüksek ret gerekçesi, faaliyet yasağına ilişkin beyanın (EK-2) uygunsuzluğundan kaynaklanmıştır. İlgili uygunsuzluk %61,90 oran ile 39 projenin reddedilmesine sebep olmuştur. Başvurularda en çok yapılan bir diğer hata %14,28 ile tapu ve muvafakatnamedeki eksikliklerden kaynaklıdır. Belirtilen hatadan kaynaklı %14,28 ile 9 proje reddedilmiştir (TREDAŞ, 2023).

UEDAŞ'a yapılan başvuruların ret gerekçeleri ile ilgili detaylar Tablo 10'da verilmiştir (UEDAŞ, 2023).

**Tablo 10.** UEDAŞ firmasına yapılan proje başvuruların ret gerekçeleri

UEDAŞ Firması Ret Gerekçeleri	Ret Gerekçelerinin Sayısı	Yüzdeler Hata (%)
Tekil Kod / abone grubu bilgisi hatalı	1	0,540
EK-1	1	0,540
EK-2	54	29,189
EK-4	41	22,162
Tapu / muvafakatname	43	23,243
2 yıllık kira sözleşmesi, kira kontratı, kullanım hakkını gösterir belge	36	19,459
Siteler, apartmanlar için karar defterindeki kararın noter onaylı sureti	4	2,162
Başvuru sahibi gerçek kişi ise kimlik sureti aslıyla birlikte sunulmalı	8	4,324
Şirketler tarafından yapılan başvurularda, yetki belgesi aslı veya onaylı suretleri veya aslıyla birlikte sunulacak fotokopileri	7	3,783
Başvuru evrakları için imza beyanı / sirküsü	38	20,540
Vekaletname / Vekil kişi / Şirketin İmza Beyanı / sirküsü	51	27,567
Abonelik olduğunu gösterir belge, ruhsat durumları, abonelik aşamaları	21	11,351
Tesisin kurulması planlanan adres ile projede yer alan adres farklı (tesisat sahibi farklı)	1	0,540
Kurulması planlanan üretim tesisi kurulu gücü sözleşme gücünden fazla olan başvurular	3	1,621
Bağlantı anlaşması süresi doldu	-	-
Proje reddedilme / eksik (hatalı) evrak ve talep kaynaklı proje iptali	1	0,540
Tüketim birleştirme yapılamaz	-	-
Sözleşme gücü ve başvuru türü belirtilmemiştir	-	-
EİGM TDF formlarının yazılı ve CD sunumunda tesis adı farklı belirtilmiş. Başvuru güç, abone türü bilgileri eksik	-	-
Tek Hat şeması sunulmamış	-	-
Usul ve Esaslar 6. Madde 1. Fıkra	-	-

UEDAŞ'a 2018 yılında toplam 33 adet başvuru yapılmıştır. 2018 yılında yapılan başvuruların %45,45'i kabul, %55,55'i reddedilmiştir. 2019 yılında toplam 47 adet başvuru yapılmıştır. 2019 yılında yapılan başvuruların % 65,96'sı kabul, %34,04'ü ise reddedilmiştir. 2020 yılında toplam 77 adet başvuru yapılmıştır. 2020 yılında yapılan başvuruların % 36,36'sı kabul, %63,64'ü ise reddedilmiştir. 2021 yılında toplam 110 adet başvuru yapılmıştır. 2021 yılında yapılan başvuruların %70'i kabul, %10'u ise reddedilmiştir. 2022 yılında toplam 265 adet başvuru yapılmıştır. 2022 yılında yapılan başvuruların %78,87'si kabul, %21,13'ü ise reddedilmiştir. 2018-2022 yılları arasında toplam 532 proje başvurusunun %65,22'si kabul, %34,77'si ise reddedilmiştir (UEDAŞ, 2023).

Tablo 10' da verilen, UEDAŞ tarafından belirtilen ret gerekçeleri incelendiğinde; en yüksek ret gerekçesi, faaliyet yasağına ilişkin beyanın (EK-2) uygunsuzluğundan kaynaklanmıştır. İlgili uygunsuzluk %29,19 oran ile 54 projenin reddedilmesine sebep olmuştur. Başvurularda en çok yapılan bir diğer uygunsuzluk ise; vekaletname, vekil kişi, şirketin imza beyanı veya sirküsünden kaynaklanan uygunsuzluktur. Bu uygunsuzluk nedeniyle, 51 proje (%27,57) reddedilmiştir (UEDAŞ, 2023).

Marmara Bölgesinin genelinde faaliyet yürüten tüm EDAŞ'lara yapılan başvuruların ret gerekçeleri ile ilgili detaylar Tablo 11'de verilmiştir (AYEDAŞ, 2023; BEDAŞ, 2023; SEDAŞ, 2023; TREDASA, 2023; UEDAŞ, 2023).

**Tablo 11.** Marmara Bölgesinde LEÜ Kapsamında Yapılan Başvurular ve Ret Gerekçeleri

Marmara Bölgesi EDAŞ'larının Ret Gerekçeleri	Ret Gerekçelerinin Sayısı	Yüzdeler Hata (%)
Tekil Kod / abone grubu bilgisi hatalı	17	3,427
EK-1	3	0,605
EK-2	128	25,806
EK-4	75	15,121
Tapu / muvafakatname	100	20,161
2 yıllık kira Sözleşmesi, kira kontratı, kullanım hakkını gösterir belge	68	13,710
Siteler, apartmanlar için karar defterindeki kararın noter onaylı sureti	31	6,25
Başvuru sahibi gerçek kişi ise kimlik sureti asıyla birlikte sunulmalı	10	2,016
Şirketler tarafından yapılan başvurularda, yetki belgesi aslı veya onaylı suretleri veya asıyla birlikte sunulacak fotokopileri	44	8,871
Başvuru evrakları için imza beyanı / sirküsü	45	9,072
Vekaletname / Vekil kişi / Şirketin İmza Beyanı / sirküsü	67	13,508
Abonelik olduğunu gösterir belge, ruhsat durumları, abonelik aşamaları	34	6,854
Tesisin kurulması planlanan adres ile projede yer alan adres farklı (tesisat sahibi farklı)	12	2,420
Kurulması planlanan üretim tesisi kurulu gücü sözleşme gücünden fazla olan başvurular	59	11,895
Bağlantı anlaşması süresi doldu	72	14,516
Proje reddedilme / eksik (hatalı) evrak ve talep kaynaklı proje iptali	10	2,016
Tüketim birleştirme yapılamaz	1	0,201
Bir tüketim tesisi için birden fazla başvuru yapıldığı görülmüştür	2	0,403
Sözleşme gücü ve başvuru türü belirtilmemiştir	1	0,201
EİGM TDF formlarının yazılı ve CD sunumunda tesis adı farklı belirtilmiş.	5	1,008
Başvuru güç, abone türü bilgileri eksik		
Tek Hat şeması sunulmamış	2	0,403
Usul ve Esaslar 6. Madde 1. Fıkra	7	1,411

Marmara Bölgesinde EDAŞ'lara yapılan başvurular değerlendirildiğinde en yüksek ret gerekçenin faaliyet yasağına ilişkin beyanın (EK-2) uygunsuzluğundan kaynaklandığı belirlenmiştir. Faaliyet yasağına ilişkin beyanın eksik ve/veya hatalı olmasından kaynaklı toplam 128 proje (%25,81) reddedilmiştir. Başvurularda ikinci yüksek ret gerekçesi, proje dosyasında tapu/muvafakatnamenin eksik veya yer almamasından kaynaklanmıştır. Tapu/muvafakatname hazırlanmasında yapılan hatalardan kaynaklı 100 proje (projelerin %20,16'sı) nin reddedilmiştir. EDAŞ'lara yapılan başvurularda bağlantı görüşü alıp süresini dolduran 72 proje olduğu görülmüştür. Başvuruların sürecini geçirmek uygunsuz bulunduğu ret kriterleri içerisinde değerlendirilmiştir (AYEDAŞ, 2023; BEDAŞ, 2023; SEDAŞ, 2023; TREDAŞ, 2023; UEDAŞ, 2023).

#### 4.Sonuç

Dünya genelinde şehirler, sera gazı emisyonlarının %70'lik bölümüne neden olmaktadır (UNFCC, 2022). Şehirlerin sera gazı emisyonlarını azaltmak için YEK'lere dayalı üretim tesislerinin kurulması gereklidir. Dünya genelinde kullanımda olan binalar CO<sub>2</sub> emisyonunun %70'ini oluşturmaktadır. Binalar enerji tüketiminin %40'ından sorumludur (Malhotra, 2022). Binalarda emisyon azaltımını sağlamak için, binalarda YEK kullanımı artırılmalıdır. Neredeyse Sıfır Enerjili Bina (NSEB) Yönetmeliği kapsamında, 2023 yılına kadar 5000 m<sup>2</sup>'den büyük olan tüm binaların enerji tüketiminin %5'i YEK'e dayalı üretim tesisinden karşılanması zorunlu hale getirilmiştir. Bu oran 2025 yılından itibaren 2000 m<sup>2</sup>'den büyük yapılar için enerji tüketim ihtiyacının %10'unu YEK'e dayalı üretim tesislerinden karşılamak şeklinde uygulanacaktır (BEPY, 2022). Sürdürülebilir Kalkınma Hedefleri (SKH) yedinci maddesinde 2030 yılına kadar yenilenebilir enerji yatırımları artırarak enerji tüketimindeki payını artırılması gerekli olduğu belirtilmektedir. Enerji ihtiyacını karşılamada enerji verimliliği çözümleri ve YEK'ler destekleyici niteliktedir. Türkiye, 2030 yılına kadar

emisyondan %41 emisyon azaltımı hedeflemiştir. Emisyon azaltım hedefinin sağlayabilmesi için YEK'ler belirleyici kaynak niteliği taşıdığından YEK kapasitesinin artırılması önemlidir (UNFCC, 2023).

Meskenlerde kurulacak olan 25 kW'a kadar çatı ve cephe tipi GES'ler ile LEÜ gerçekleştirilebilmektedir. Çatı ve cephe GES kurulumları ile ilgili proje onayı ve kabul işlemleri EDAŞ'lar tarafından gerçekleştirilmektedir. EDAŞ'lara yapılan başvuru sayıları enerji tüketim maliyetlerinin artması ile doğru orantılı olarak artış göstermiştir. Proje başvuru sayısının artması hataları da beraberinde getirmektedir. Marmara Bölgesinde, 2018 yılında proje başvuru sayısı 101 iken %32,67'lik bir ret oranı oluşmuştur. Yönetmeliğin yeni çıkması, şebeke işletmecisinin usul ve esaslara haiz olması için belirli bir süre geçmesi gereklidir. 2019 yılında 110 proje başvurusunun %27,27'si hatalı gözükmektedir. SEDAŞ'ın internet adresi üzerindeki 2019 yılı verileri olmasına karşın verilerin indirilmeye çalışıldığı esnada erişim sağlanamamıştır. Marmara bölgesinde 2019 yılında SEDAŞ'ın verilerinin eksik olmasından kaynaklı hata oranları eksik sonuçlandırılmıştır. 2022 yılında proje başvuru sayısı 2018'e göre 8,4 kat artmasına karşın hata oranı %23,41 seviyelerindedir. Kümülatif olarak proje sayısı artmasına karşın hata oranında %9,26'lık bir azalma olduğu görülmeye karşın reddedilen proje sayılarında artış olmuştur. 2022 yılında, 25 kW'a kadar çatı ve cephe GES tesisleri için yapılan proje başvurularında üretim tesisinin kurulu gücü tüketim tesisi sözleşme gücünden fazla olamayacağı belirtilmesine karşın 40 proje olumsuz sonuçlanmıştır. 2022 yılında, faaliyet yasağına ilişkin beyan usul ve esaslarda paylaşılmış ve belirtilmiş olmasına karşın 31 proje olumsuz sonuçlanmıştır. 2018-2022 yılları arasında kümülatif olarak 1727 başvuru yapılmıştır. Başvuruların %72,03'ü uygun görülmüş %27,97'si reddedilmiştir. 2018-2022 yılları arasında yapılan başvurularda en yüksek ret, %25,81'lik oran ile EK-2 hatası kaynaklı olmuştur. Başvuru sonuçlarında ikinci hatanın %20,16 ile tapu/muvafakatname kaynaklı olduğu görülmüştür. Başvuru sonuçlarında üçüncü hata %13,71 ile 2 yıllık kira sözleşmesi, kira sözleşmesi, kullanım hakkını gösterir belgenin eksik ve/veya hatalı hazırlanmasından kaynaklı olmuştur. Bağlantı görüşü ve çağrı mektubu oluşturulmuş projelerin bağlantı anlaşması süresinin dolmasından kaynaklı 72 proje iptal edilmiştir. Bağlantı görüşü alan projelerin tamamlanmadan iptal edilmesi başvuru sahibine zaman kaybına sebep olmaktadır. Bu durum, başvuru sahibinin projeyi ekonomik bulmayıp, vazgeçmesi sonucu da oluşmuş olabilir.

10 kW ve altı çatı ve cephe uygulamaları usul ve esasları 2018 yılında duyurusu yapılmıştır. 2022 yılına kadar azami kurulu güç miktarı 10 kW olarak belirlenmiştir. 2022 yılında 10 kW olan azami kurulu güç seviyesi 25 kW'a yükseltilmiştir. Başvurularda istenen evraklarda bir değişiklik olmamasına karşın 2022 yılında yapılan başvurular incelendiğinde ret gerekçeleri incelenmeden başvuru yapıldığından aynı hatalar alınmaktadır. EDAŞ'lar internet adresleri üzerinden gerekçeleri paylaşılmaktadır. Başvuru sahipleri daha önce reddedilen projeleri inceleyerek eksik olabilecek hususları belirleyebilir.

## 5. Tartışma ve Öneriler

Çatı ve cephe uygulamalarında kabul oranlarının artırılması, Türkiye'nin lisanssız GES kurulu gücünü artıracaktır. Bu nedenle, çatı ve cephe tipi GES başvurularında bazı iyileştirmelerin yapılması gereklidir.

EDAŞ'lara yapılan başvurularda 25 kW'a kadar çatı ve cephe GES'ler için oluşturulan usul ve esaslara göre başvurular değerlendirilmektedir. EDAŞ'ların paylaşmış olduğu başvuru sonuçları incelendiğinde 3 projenin gerekçesi olarak EK-1 belirtilmiştir. Usul ve esaslarda başvuru için gerekli bilgi ve belge listesinin gerekçe olarak gösterilmesi projenin uygunsuz bulma gerekçesini net bir şekilde ifade etmemektedir. Proje başvuru sahipleri bu hususu gördüğünde eksik evrak için tekrardan EDAŞ'a başvurması gerekmektedir. Benzer şekilde usul ve esasların 6. madde 1.fıkrası içeriğinde eksik başvuruda bulunanların şebeke işletmecisi tarafından değerlendirmeye alınmayacağı ve talep edilmesi durumunda evrakların iade edilebileceğini ifade etmektedir. 2018-2022 yılları arasında EDAŞ'a yapılan başvuru sonucunda 7 proje Usul ve Esaslarda yer alan 6. Madde 1. Fıkra gerekçe olarak gösterilmiştir. Usul ve Esaslarda yer alan 6. Madde 1. Fıkra gerekçe olarak verildiğinde başvuru sahipleri eksik evrağı tamamlayıp tekrardan başvurmasının önünde engel oluşturmaktadır. EDAŞ'lar başvuruda yer alan eksik evrakları net bir şekilde ret gerekçesi olarak belirtmelidir. Eksik evrakların tamamlanması için ek süre verilmeli, başvuru süreci sonlandırılmamalıdır.

Proje başvurusu esnasında ilgili EDAŞ ile sözleşme imzalanması gereklidir. Çatı ve cephe GES uygulamalarında çağrı mektubu alındıktan sonra projeler tamamlanmadan iptal olmaktadır. Proje sahipleri dilediği şekilde çağrı mektubunun süresi geçerken herhangi yasal bir yaptırım uygulanmadığı için bağlantı görüşü oluşturulan projeler uygulanmadan iptal edilebilmektedir. Bağlantı görüşü ve çağrı mektubu

oluşturulduktan sonraki süreçte şebeke işletmecisi ile sözleşme imzaladığı durumda projeler belirtilen 90 ve/veya 180 gün içerisinde tamamlanacaktır. Sözleşmenin içeriğinde cayma bedeli belirlenmelidir. Cayma bedeli, olumlu sonuçlanan, bağlantı görüşü ve çağrı mektubu alınan projelerin kurulumlarını tamamlama gerekliliği oluşturacaktır. Bağlantı görüşü ve çağrı mektubu alınan projeler süresi dolmadan tamamlanacak ve deneme amaçlı yapılan başvuruların önüne geçecektir. Bağlantı anlaşması süresi dolup iptal olan projelerin azalmasını sağlayacaktır. EDAŞ'ların 25 kW'a kadar çatı ve cephe GES proje başvuru değerlendirmesi ve inceleme sürecini azaltmak adına başvurular online sisteme taşınmalı, ön başvuru sistemi oluşturularak aboneliğin uygunluğu değerlendirilmelidir.

EDAŞ'lara başvuruda bulunmak isteyen proje sahiplerine başvuru öncesi eğitim verilmesi hata oranlarını azaltabilecektir.

Çatı ve cephe uygulamaları için kurulabilecek 25 kW GES'ler, müstakil konutların elektrik tüketimini karşılamada günümüzde yeterli gözükmez. Toplu konut alanları, apartman ve sitelerde elektrik tüketiminin karşılanması için site ve apartman karar sakinlerinde izin alınarak kurulabilmektedir. Çatı ve cephe uygulamalarında site, apartmanlar için tüketim birleştirmesine izin verilmesi durumunda aynı noktadan daha yüksek güçte üretim tesisi kurulabilecektir.

25 kW azami kurulu güce sahip olacak GES'lerde atıl durumda alanı bulunan dinlenme, otopark, vb. kısımlar için harici kapasite tahsisi verilebilir. Tüketim birleştirme yapılarak kurulu güç değeri artırılabilir. Çatı ve cephe uygulamalarında 25 kW azami kurulu güç belirlenmiştir. Proje başvurularında bireysel EA şarj istasyonu olması durumunda şarj istasyonu kapasitesi kadar ek kurulu güç tahsis edilebilir.

Meskenlerde yenilenebilir enerjiye önemine yönelik lisanssız elektrik üretimi yapan abone gruplarında elektrik tarifelerinde değişiklik veya indirimli elektrik tarifesiyle yararlanma imkanı sağlanmalıdır. 25 kW çatı ve cephe GES kurulumu yapan kişilere verilecek destek ile uygulamanın yerele yayılması sağlanabilir.

### Referanslar

Aksungur, M. K., Kurban, M., Başaran Filik, Ü. (2013). Türkiye'nin Farklı Bölgelerindeki Güneş Işınım Verilerinin Analizi ve Değerlendirilmesi, *V. Enerji Verimliliği ve Kalitesi Sempozyumu*, Kocaeli, Türkiye, 23-24 Mayıs 2013.

Binalarda Enerji Performansı Yönetmeliği. (BEPY). (2022). 19/02/2022 tarihli 31755 sayılı Resmi Gazete, Ankara.

Boğaziçi Elektrik Dağıtım A.Ş. (BEDAŞ). (2023). 25kW ve Altı Çatı-Cephe GES Başvuru Sonuçları. Erişim tarihi: 24 Haziran 2023, Erişim adresi: [https://www.bedas.com.tr/tr/sayfalar/235/lisanssiz\\_uretim](https://www.bedas.com.tr/tr/sayfalar/235/lisanssiz_uretim)

British Petroleum (BP). (2023) Statistical Review of World Energy 2022. Erişim adresi: <https://www.bp.com/content/dam/bp/business-sites/en/global/corporate/pdfs/energy-economics/statistical-review/bp-stats-review-2022-full-report.pdf>

Cumhurbaşkanı Kararı. (2019). 1044 sayılı Cumhurbaşkanlığı Kararı. 10/05/2019 tarihli ve 30770 sayılı Resmi Gazete, Ankara.

Elektrik Piyasası Kanunu (EPK). (2001). 4628 sayılı Elektrik Piyasası Kanunu. 3/03/2001 tarihli ve 24335 sayılı Resmi Gazete, Ankara.

Elektrik Piyasası Kanunu (EPK). (2013). 6446 sayılı Elektrik Piyasası Kanunu. 30/03/2013 tarihli ve 28603 sayılı Resmi Gazete, Ankara.

Elektrik Piyasası Kanunu (EPK). (2023). 6446 sayılı Elektrik Piyasası Kanunu. 10/04/2023 tarihli ve 32159 sayılı Resmi Gazete, Ankara.

Elektrik Dağıtım Hizmetleri Derneği (ELDER). (2023). ELDER Sektör Raporu 2022. Erişim tarihi: 12 Haziran 2023, Erişim adresi: <https://www.elder.org.tr/Content/files/3729a088-aac2-4fc4-9b00-6dc44df53445.pdf>

Elektrik Mühendisleri Odası (EMO). (2021). Türkiye Elektrik İstatistikleri – Şubat 2021. Erişim tarihi: 15 Haziran 2023, Erişim Adresi: [https://www.emo.org.tr/ekler/095e69ae7d0338f\\_ek.pdf?tipi=41&turu=X&sube=0](https://www.emo.org.tr/ekler/095e69ae7d0338f_ek.pdf?tipi=41&turu=X&sube=0)

- Enerdata. (2023). World energy & climate statistics – yearbook 2022. Erişim tarihi:10 Haziran 2023, Erişim adresi: <https://yearbook.enerdata.net/total-energy/world-energy-intensity-gdp-data.html>
- Enerji İşleri Genel Müdürlüğü (EİGM). (2023). Güneş Enerjisi Potansiyel Atlası. Erişim tarihi: 18 Haziran 2023, Erişim adresi: <https://gepa.enerji.gov.tr/MyCalculator/>
- European Environment Agency (EEA). (2023). Total greenhouse gas emissions trends and projections in Europe. Erişim adresi: <https://www.eea.europa.eu/data-and-maps/indicators/greenhouse-gas-emission-trends-8>
- European Commission (EUC). (2023). 2030 climate & energy framework. Erişim adresi:[https://climate.ec.europa.eu/eu-action/climate-strategies-targets/2030-climate-energy-framework\\_en#ref-2030-climate-and-energy-framework---existing-ambition](https://climate.ec.europa.eu/eu-action/climate-strategies-targets/2030-climate-energy-framework_en#ref-2030-climate-and-energy-framework---existing-ambition)
- International Energy Agency (IEA). (2022). Renewables 2022 – Analysis and forecast to 2027. Erişim adresi: <https://iea.blob.core.windows.net/assets/ada7af90-e280-46c4-a577-df2e4fb44254/Renewables2022.pdf>
- International Energy Agency (IEA). (2023). Share of cumulative power capacity by technology, 2010-2027. Erişim adresi: <https://www.iea.org/data-and-statistics/charts/share-of-cumulative-power-capacity-by-technology-2010-2027>
- International Renewable Energy Agency (IRENA). (2022). Renewable power generation costs in 2022. Erişim tarihi: 20 Haziran 2023, Erişim adresi: <https://www.irena.org/Publications/2023/Aug/Renewable-Power-Generation-Costs-in-2022>
- İstanbul Anadolu Yakası Elektrik Dağıtım A.Ş. (AYEDAŞ). (2023). 10 kW'a Kadar Olan GES Başvuruları Değerlendirme Listesi. Erişim tarihi: 24 Haziran 2023, Erişim adresi: <https://www.ayedas.com.tr/>
- Kayseri ve Civarı Elektrik Türk A.Ş. (KCETAŞ). (2023). Lisanssız Elektrik Üretim Başvuruları Ön Değerlendirme ve Sonuçları. Erişim tarihi: 24 Haziran 2023, Erişim adresi: <https://www.kcetas.com.tr/>
- Malhotra, A., Bischof, J., Nichersu, A., Hafele, K. H., Exenberger, J., Sood, D., ... & Schweiger, G. (2022). Information modeling for urban building energy simulation—A taxonomic review, *Building and Environment*, 208, 108552, <https://doi.org/10.1016/j.buildenv.2021.108552>
- Özcan, M. (2021). Enhancing the Renewable Energy Auctions in Turkey. *Politeknik Dergisi*, 24(4), 473-484. <https://doi.org/10.2339/politeknik.721850>
- Özyakışır, Ö. & Ünver, S. (2020). Yenilenebilir Enerji Kaynaklarına Dayalı Lisanssız Elektrik Üretimi. *Ankara Hacı Bayram Veli Üniversitesi Hukuk Fakültesi Dergisi*, 24(4), s.195-226. DOI: <https://doi.org/10.34246/ahbvuhfd.813037>
- REN21. (2023). Renewables 2022 Global Status Report. Erişim adresi: [https://www.ren21.net/wp-content/uploads/2019/05/GSR2022\\_Full\\_Report.pdf](https://www.ren21.net/wp-content/uploads/2019/05/GSR2022_Full_Report.pdf)
- Sağbaş, A. & Başbuğ, B. (2018). Sürdürülebilir kalkınma ekseninde enerji verimliliği uygulamaları: Türkiye değerlendirmesi. *European Journal of Engineering and Applied Sciences* 1(2), s. 43-50
- Sakarya Elektrik Dağıtım A.Ş. (SEDAŞ). (2023). 25 kW'a Kadar Güneş Enerjisine Dayalı Elektrik Üretim Başvuru Sonuçları. Erişim tarihi: 27 Haziran 2023, Erişim adresi: [https://www.sedas.com/Tr/icerik\\_lisanssiz-elektrik-uretimi\\_580](https://www.sedas.com/Tr/icerik_lisanssiz-elektrik-uretimi_580)
- Trakya Elektrik Dağıtım A.Ş. (TREDAS). (2023). Elektrik Piyasasında Lisanssız Elektrik Üretim Yönetmeliği Kapsamında Yapılan Başvuruların Değerlendirme Sonuçları, Erişim tarihi: 28 Haziran 2023, Erişim adresi: <https://tredas.com.tr/icerik/degerlendirme-126>
- Türkiye Cumhuriyeti Cumhurbaşkanlığı Strateji ve Bütçe Başkanlığı (SBB). (2019a). 2019-2023 Stratejik Planı. Erişim tarihi: 2 Temmuz 2023, Erişim adresi: <https://www.sbb.gov.tr/wp-content/uploads/2021/07/Strateji-ve-Butce-Baskanligi-2019-2023-Stratejik-Plani-28072021.pdf>
- Türkiye Cumhuriyeti Cumhurbaşkanlığı Strateji ve Bütçe Başkanlığı (SBB). (2019b). On Birinci Kalkınma Planı (2019-2023). Erişim tarihi: 3 Temmuz 2023, Erişim adresi: [https://www.sbb.gov.tr/wp-content/uploads/2022/07/On\\_Birinci\\_Kalkinma\\_Planı-2019-2023.pdf](https://www.sbb.gov.tr/wp-content/uploads/2022/07/On_Birinci_Kalkinma_Planı-2019-2023.pdf)



Türkiye Cumhuriyeti Çevre, Şehircilik ve İklim Değişikliği Bakanlığı (ÇŞİDB). (2023). Kişi Başına Enerji Tüketimi. Erişim tarihi: 15 Haziran 2023, Erişim adresi: <https://cevreselgostergeler.csb.gov.tr/kisi-basina-enerji-tuketimi-i-85805>

Türkiye Cumhuriyeti Enerji Piyasası Düzenleme Kurumu (EPDK). (2019). Dağıtım Lisansı Sahibi Tüzel Kişiler ve Görevli Tedarik Şirketlerinin Tarife Uygulamalarına İlişkin Usul ve Esaslarda Değişiklik Yapılması Hakkında Karar. 26/09/2019 tarihli ve 30813 sayılı Resmi Gazete, Ankara.

Türkiye Cumhuriyeti Enerji Piyasası Düzenleme Kurumu (EPDK). (2010). Elektrik Piyasasında Lisanssız Elektrik Üretimine İlişkin Yönetmelik. 21/12/2010 tarihli ve 27774 sayılı Resmi Gazete, Ankara.

Türkiye Cumhuriyeti Enerji Piyasası Düzenleme Kurumu (EPDK). (2011). Elektrik Piyasasında Lisanssız Elektrik Üretimine İlişkin Yönetmelik. 21/07/2011 tarihli ve 28001 sayılı Resmi Gazete, Ankara.

Türkiye Cumhuriyeti Enerji Piyasası Düzenleme Kurumu (EPDK). (2013). Elektrik Piyasasında Lisanssız Elektrik Üretimine İlişkin Yönetmeliğin Uygulanmasına Dair Tebliğ. 2/10/2013 tarihli ve 28783 sayılı Resmi Gazete, Ankara.

Türkiye Cumhuriyeti Enerji Piyasası Düzenleme Kurumu (EPDK). (2019a). Elektrik Piyasasında Lisanssız Elektrik Üretim Yönetmeliğinde Değişiklik Yapılmasına Dair Yönetmelik. 12/05/2019 tarihli ve 30772 sayılı Resmi Gazete, Ankara.

Türkiye Cumhuriyeti Enerji Piyasası Düzenleme Kurumu (EPDK). (2022). Elektrik Piyasasında Lisanssız Elektrik Üretim Yönetmeliğinde Değişiklik Yapılmasına Dair Yönetmelik. 11/08/2022 tarihli ve 31920 sayılı Resmi Gazete, Ankara.

Türkiye Cumhuriyeti Enerji Piyasası Düzenleme Kurumu (EPDK). (2019b). YEKA-2 GES İptal İlanı. Erişim tarihi: 10 Temmuz 2023, Erişim Adresi: <https://www.resmigazete.gov.tr/ilanlar/eskiilanlar/2019/01/20190113-4-2.pdf>

Türkiye Cumhuriyeti Enerji Piyasası Düzenleme Kurumu (EPDK). (2023b). 25 kW'a kadar güneş enerjisine dayalı elektrik üretim tesisleri için usul ve esaslar. Erişim tarihi: 27 Haziran 2023, Erişim adresi: <https://www.epdk.gov.tr/Detay/Icerik/3-0-92-3/elektriklisanssiz-uretim>

Türkiye Cumhuriyeti Enerji Piyasası Düzenleme Kurumu (EPDK). (2023a). 2014-2022 Yılları Elektrik Piyasası Gelişim Raporları. Erişim tarihi: 17 Haziran 2023, Erişim adresi: <https://www.epdk.gov.tr/Detay/Icerik/3-0-24/yillik-sektor-raporu>

Türkiye Cumhuriyeti Enerji Piyasası Düzenleme Kurumu (EPDK). (2018). 7590 sayılı Karar. Elektrik Piyasasında Tüketim Tesisi ile Aynı Ölçüm Noktasından Bağlı ve Güneş Enerjisine Dayalı Üretim Tesisleri için Lisanssız Üretim Başvurularına ve İhtiyaç Fazlası Enerjinin Değerlendirilmesine İlişkin Usul ve Esaslar. 18/01/2018 tarihli ve 30305 sayılı Resmi Gazete, Ankara.

Türkiye Cumhuriyeti Enerji ve Tabii Kaynaklar Bakanlığı (ETKB). (2023a). Elektrik. Erişim tarihi: 10 Haziran 2023, Erişim adresi: <https://enerji.gov.tr/bilgi-merkezi-enerji-elektrik>

Türkiye Cumhuriyeti Enerji ve Tabii Kaynaklar Bakanlığı (ETKB). (2023b). Yenilenebilir Enerji Kaynak Alanları (YEKA) Modeli ve Uygulamaları. Erişim tarihi, 20 Temmuz 2023, Erişim Adresi: <https://enerji.gov.tr/eigm-yenilenebilir-enerji-uretim-faaliyetleri-yeka-modeli>

Türkiye Cumhuriyeti Enerji ve Tabii Kaynaklar Bakanlığı (ETKB). (2021). YEKA GES-3 Yarışmalarında En Düşük Fiyat Teklifi Öneren Tüzel Kişiler ile Önerilen En Düşük Fiyat Teklifleri. Erişim tarihi: 15 Temmuz 2023, Erişim Adresi: [https://enerji.gov.tr/Media/Dizin/BHIM/tr/Duyurular/YEKAGES3YARI%C5%9EMASONU%C3%87LARI\\_202105291210.pdf](https://enerji.gov.tr/Media/Dizin/BHIM/tr/Duyurular/YEKAGES3YARI%C5%9EMASONU%C3%87LARI_202105291210.pdf)

Türkiye Cumhuriyeti Enerji ve Tabii Kaynaklar Bakanlığı (ETKB). (2022). Yenilenebilir Enerji Kaynak Alanları (YEKA) İlanı. 3/02/2022 tarihli ve 31739 sayılı Resmi Gazete, Ankara.

Türkiye Cumhuriyeti Enerji ve Tabii Kaynaklar Bakanlığı (ETKB). (2023c). Türkiye Ulusal Enerji Planı. Erişim tarihi: 3 Temmuz 2023, Erişim Adresi: [https://enerji.gov.tr/Media/Dizin/EIGM/tr/Raporlar/TUEP/T%C3%BCrkiye\\_Ulusal\\_Enerji\\_Plan%C4%B1.pdf](https://enerji.gov.tr/Media/Dizin/EIGM/tr/Raporlar/TUEP/T%C3%BCrkiye_Ulusal_Enerji_Plan%C4%B1.pdf)

Türkiye Elektrik Dağıtım A.Ş. (TEDAŞ). (2023). Hakkımızda. Erişim tarihi: 21 Haziran 2023, Erişim adresi: <https://www.tedas.gov.tr/tr/1/hakkimizda>

Türkiye Elektrik Dağıtım A.Ş. (TEDAŞ). (2018). Lisanssız Elektrik Üretim Yönetmeliği Kapsamında 10 kW ve altı Çatı ve Cephe Uygulamaları Güneş Elektrik Üretim Tesisleri için Tip Proje ve Ekleri. Erişim tarihi: 16 Haziran 2023, Erişim Adresi: <https://www.tedas.gov.tr/FileUpload/MediaFolder/cea26c97-a5bf-4dc8-903a-c4890c62fc0f.pdf>

Türkiye Elektrik İletim A.Ş. (TEİAŞ). (2022). Yük Tevzi Dairesi Başkanlığı- Kurulu Güç Raporu-Aralık 2022. Erişim tarihi: 15 Haziran 2023, Erişim adresi: <https://www.teias.gov.tr/kurulu-guc-raporlari>

Türkiye İstatistik Kurumu (TÜİK). (2023). Konut İstatistikleri. Erişim tarihi: 26 Temmuz 2023, Erişim adresi: <https://nip.tuik.gov.tr/?value=KonutIstatistikleri>

Uludağ Elektrik Dağıtım A.Ş (UEDAŞ). (2023). Lisanssız Elektrik Üretimine Dayalı Güneş Enerji Santralleri Değerlendirme Sonuçları. Erişim tarihi: 30 Haziran 2023, Erişim adresi (10.08.2023): <https://www.uedas.com.tr/tr>

United Nations Framework Convention on Climate Change (UNFCCC). (2022). The road to sustainable mobility in cities. Erişim tarihi: 2 Eylül 2023, Erişim adresi: [https://unfccc.int/sites/default/files/resource/COP27\\_%20The\\_road\\_to\\_sustainable\\_mobility\\_in\\_cities\\_1711\\_1711\\_0.pdf](https://unfccc.int/sites/default/files/resource/COP27_%20The_road_to_sustainable_mobility_in_cities_1711_1711_0.pdf)

United Nations Framework Convention on Climate Change (UNFCCC). (2023). Republic of Türkiye Updated First Nationally Determined Contribution. Erişim tarihi: 2 Eylül 2023, Erişim adresi: [https://unfccc.int/sites/default/files/NDC/2023-04/T%C3%9CRK%C4%B0YE\\_UPDATED%201st%20NDC\\_EN.pdf](https://unfccc.int/sites/default/files/NDC/2023-04/T%C3%9CRK%C4%B0YE_UPDATED%201st%20NDC_EN.pdf)

Yenilenebilir Enerji Kaynaklarının Elektrik Enerjisi Üretimi Amaçlı Kullanımına İlişkin 5346 sayılı Kanun. (2005). 10/05/2005 tarihli ve 28603 sayılı Resmî Gazete, Ankara.



## DETERMINATION OF DESIGN PARAMETERS FOR A TROUGH-TYPE PARABOLIC SOLAR COLLECTOR

**Mevlüde Merve KARA**

Osmaniye Korkut Ata University, Faculty of Engineering, Department of Energy Systems Engineering, Osmaniye-Türkiye  
ORCID: <https://orcid.org/0000-0003-1248-843X>

**Bülent YANIKTEPE**

Assoc. Prof. Dr., Osmaniye Korkut Ata University, Faculty of Engineering, Department of Energy Systems Engineering, Osmaniye-Türkiye, ORCID: <https://orcid.org/0000-0001-8958-4687>

**Osman KARA**

Assist. Prof. Dr., Osmaniye Korkut Ata University, Faculty of Engineering, Department of Energy Systems Engineering, Osmaniye-Türkiye, ORCID: <https://orcid.org/0000-0003-1501-677X>

### ABSTRACT

The use of fossil fuels causes negative effects such as climate change, global warming, greenhouse gas emissions, acid rain, environmental pollution, water pollution, increased carbon footprint, and depletion of the ozone layer. Today, in order to reduce the effects of fossil fuel consumption, which negatively affects all living things, alternative energy sources such as solar, wind, geothermal, hydrogen, wave and biomass energy sources, which are environmentally friendly and carbon emission-reducing renewable energy sources called green energy, are used instead of fossil fuel consumption. In this study, solar energy was used as a renewable energy source, and the generation of heat energy from solar energy and electrical energy from heat energy was modeled. In this context, a trough-type parabolic collector was designed as an energy conversion model. For the trough-type parabolic collector design, the collector length ( $L_x$ ), collector width ( $W_x$ ), edge angle ( $\alpha_r$ ), peak angle ( $\alpha_s$ ), and spreading angle ( $\square$ ) were determined and using the determined values, the trough-type parabolic collector; focal length ( $k$ ), distance from the center of the vacuum tube pipe to the reflective inner surface of the trough-type parabolic collector ( $k_1$ ), height of the collector ( $k_2$ ), length of the inner surface of the collector (LPYU) and minimum diameter required for the vacuum tube pipe ( $D_{min}$ ) were calculated. As a result of the calculations, with the design parameters determined for the trough-type parabolic collector ( $W_x = 6$  m,  $L_x = 15$  m,  $\alpha_r = 80^\circ$ ,  $\alpha_s = 0.53^\circ$  and  $\square = 0.6^\circ$ ), the focal length,  $k = 1.7876$  m, is from the center of the vacuum tube pipe. It was obtained as the distance from the reflective inner surface of the trough-type parabolic collector,  $k_1 = 528.9809$  mm, the height of the collector,  $k_2 = 1258.6494$  mm, the length of the inner surface of the collector, LPYU = 6.6438 m and the minimum diameter required for the vacuum tube pipe,  $D_{min} = 60.0784$  mm.

**Keywords:** Trough-Type Parabolic Collector Design, Renewable Energy, Solar Energy

### Introduction

Today, the increase in energy demand increases fossil fuel use and foreign dependency. It has been observed that if the increase in energy demand is met by using solar energy, which is a clean and renewable energy source, fossil fuel use and foreign dependency will decrease (Yanıktepe et al., 2021). Trough-type parabolic collectors, which are among solar energy applications, can be used to prevent factors that negatively affect living life, such as fossil fuel use, air pollution, greenhouse gas emissions, external dependency, and depletion of the ozone layer.

There are many studies in the literature regarding trough-type parabolic collector design. Şanlı (2010), theoretically designed a trough-type parabolic collector. In 2009-2010, the collector designed using solar data from Denizli province was tested, and the efficiency of the system up to the steam turbine was found to be 67%. The steam turbine capacity of the installed system was calculated to be in the range of 300–500 kW. A. V. Arasu and T. Sornakumar (2007) discussed the design and manufacturing of glass fiber-reinforced trough-type parabolic collectors. The standard deviation of the errors occurring on the parabolic surface was found to

be 0.0066 rad, according to ASHRAE Standard 93 (1986). As a result, the performance test of the designed glass fiber-reinforced trough-type parabolic collector was found to be successful. H. Hoseinzadeh et al. (2018) Using the Monte Carlo Method in MATLAB in their studies, they designed a parabolic collector by changing the receiver diameter, collector aperture width, and frame angle. In the first designed system, the optical efficiency of the system with a collector aperture width of 0.6 m, a frame angle of 100°, and a receiver diameter of 0.025 m was found to be 65%. In the second-designed system, the optical efficiency of the system with a collector aperture width of 0.7 m, a frame angle of 90°, and a receiver diameter of 0.025 m was calculated at 61%. Üçgül et al. (2003) Using the insolation data received from the Meteorology Directorate for the months of May, June, July, and August in Isparta province, the total energy collected in the receiver was calculated by looking at the geometry of the parabolic trough type collector and the characteristics of the radiation coming to the reflective surface. Chafiou and Üçgül (2022), They explained the solar energy potential, solar radiation, and the equations required for sizing the parabolic trough-type solar concentrator for the Comoros Islands. Theoretically, he designed a 400 kWe parabolic trough-type solar concentrator system and an ORC turbine power generation system for electricity production. As a result, they stated that the designed system will work efficiently in the Comoros Islands. Yanıktepe et al. They used four different models to estimate solar energy in Osmaniye province. As a result, it is seen that the solar energy potential for Osmaniye province is high (2017). Çağlar and Talay(2019), compared four types of parabolic trough-type collectors: glass cover diameter, absorber pipe diameter, absorber pipe material, and absorber pipe thickness. It has been observed that the absorber pipe material and diameter have a positive effect on parabolic collector efficiency. The effect of Ebrazeh and Sheikholeslami nanomaterial use on the thermal efficiency of the trough-type parabolic collector was investigated. As a result, it has been determined that the use of nanomaterials increases the efficiency of trough-type parabolic collectors (2020).

In this study, the design of a trough-type parabolic solar collector is discussed. Parameters such as collector width, collector length, edge angle, peak angle, and spreading angle were accepted in the study. Using these accepted parameters, the focal length, the distance from the center of the vacuum tube pipe to the reflective inner surface of the trough-type parabolic collector, the height of the parabolic collector, the length of the inner surface of the collector, and the minimum diameter required for the vacuum tube pipe were calculated.

**Materials and Methods**

A trough-type parabolic collector design was made by determining parameters such as collector width, collector length, edge angle, peak angle, and spreading angle. Trough-type parabolic collector design parameters were calculated using the equations (1–5) given below.

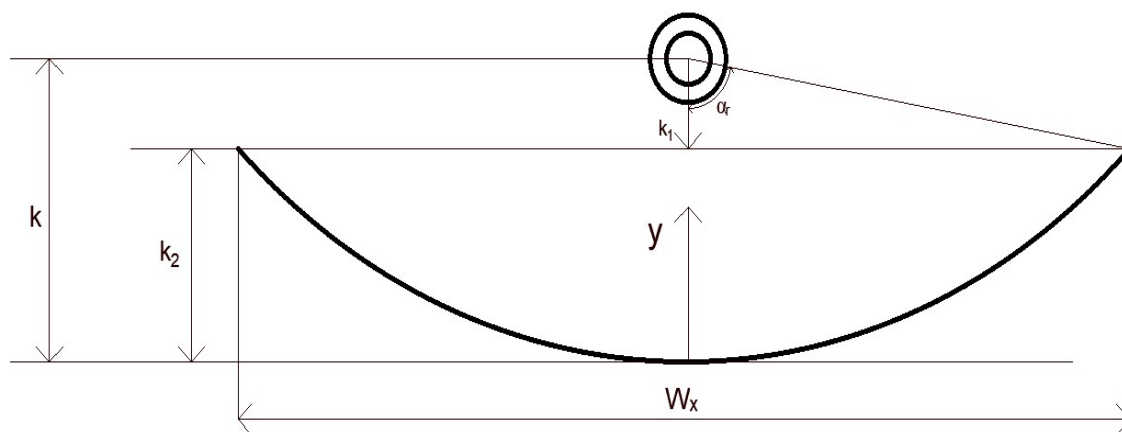

**Figure 1:** Trough-Type Parabolic Collector Design Parameters

The general equation of the trough-type parabolic solar collector is given in equation 1. (Deceased and Beckman 1982):

$$y = \frac{x^2}{4k} \tag{1}$$

The distances to the x and y axes given in Equation 1 are the distances from the reflecting surface of the parabolic collector to the focal point.

The side angle equation is given in equation 2. (Deceased and Beckman 1982):

$$\alpha_r = \tan^{-1} \left[ \frac{8 \left( \frac{k}{W_x} \right)}{16 \left( \frac{k}{W_x} \right)^2 - 1} \right] = \sin^{-1} \left( \frac{W_x}{2r_r} \right) \tag{2}$$

The local reflective radius equation at any point on the reflective surface of the parabolic collector is as in equation 3. (Deceased and Beckman 1982):

$$r = \frac{2k}{1 + \cos \alpha_r} \tag{3}$$

The length of the reflective surface of the parabolic collector is calculated as in equation 4, accepting the midpoint of the parabola as 0,0 coordinates. (Deceased and Beckman 1982):

$$L_{PYU} = 2 \int_a^b \left( \sqrt{1 + (y')^2} \right) dx \tag{4}$$

The minimum diameter of the vacuum tube pipe is calculated using equation 5 (Deceased and Beckman 1982):

$$D_{min} = \frac{W_x}{\sin \alpha_r} \sin (\alpha_s + \square/2) \tag{5}$$

**Findings and Discussion**

The assumptions used for the parabolic collector considered are given in Table 1.

**Table 1:** Assumptions Used in The Calculations of the Designed Trough Type Parabolic Collector

Collector Width	6 m
Collector Length	15 m
Edge Angle	80°
Peak Angle	0.53°
Spreading Angle	0.6°

By determining the collector width as 6 m, the collector length as 15 m, the edge angle as 80°, the top angle as 0.53°, and the spreading angle as 0.6°, the focal length is determined as the distance from the center of the vacuum tube pipe to the reflective inner surface of the trough-type parabolic collector, the height of the parabolic collector, and the inner surface of the collector. The length and minimum diameter required for the vacuum tube pipe were calculated.

**Conclusion and Recommendations**

Renewable energy sources are of great importance in preventing negative impacts such as air, water, and soil pollution caused by fossil fuel consumption. In this study, a trough-type parabolic collector design, which is one of the renewable energy sources and solar energy applications, was designed. Using the accepted values, the focal length was calculated as 1.7876 m, the distance from the center of the vacuum tube pipe to the reflective inner surface of the trough-type parabolic collector as 528.9809 mm, the height of the parabolic collector as 1258.6494 mm, the length of the inner surface of the collector as 6.6438 m, and the minimum diameter required for the vacuum tube pipe as 60.0784 mm.

**Thanks and Information Note**

The authors would like to thank OKU Scientific Research Projects Unit for their support with the project number OKÜBAP-2023-PT2-007.

**References**

- Çağlar, A. & Talay İ. B. 2019. “Tasari Parametrelerinin Parabolik Olu Tipi Bir Güneş Kollektörünün Performansına Etkisi.” *Uludağ Üniversitesi Mühendislik Fakültesi Dergisi*, Cilt 24:15–24. doi: 10.17482/uumfd.431652.
- CHAFIOU, H. & Üçgül, İ. 2022. “Energy Generation With Parabolic Trough Solar Collector In Comoros Islands.” *Uluslararası Teknolojik Bilimler Dergisi* 14(1):30–39. doi: 10.55974/utbd.1065773.
- Deceased, John A. Duffie, and William A. Beckman. 1982. *Solar Engineering of Thermal Processes*. Vol. 3.
- Ebraze, Sh. & Sheikholeslami, M. 2020. “Applications of Nanomaterial for Parabolic Trough Collector.” *Powder Technology* 375:472–92. doi: 10.1016/j.powtec.2020.08.005.
- Hoseinzadeh, H. Kasaeian, A. & Shafii, M. B. 2018. “Geometric Optimization of Parabolic Trough Solar Collector Based on the Local Concentration Ratio Using the Monte Carlo Method.” *Energy Conversion and Management* 175(April):278–87. doi: 10.1016/j.enconman.2018.09.001.
- Üçgül, İ. Öztürk, M. & Özek, N. 1. n.d. “Parabolik Kollektörlerin Optik, Enerjetik ve Ekserjetik Verimliliklerinin Analizi.” 49–56.
- Şanlı, G. 2010. “Parabolik Oluk Tipi Güneş Kollektörlerinin Teorik Olarak İncelenmesi.” *YÖK Tez Merkezi* 127.
- Arasu, A. V., & Sornakumar, T. 2007. “Design, Manufacture and Testing of Fiberglass Reinforced Parabolic Trough for Parabolic Trough Solar Collectors.” *Solar Energy* 81(10):1273–79. doi: 10.1016/j.solener.2007.01.005.
- Yanıktepe, B. Kara, O. & Ozalp, C. 2017. “The Global Solar Radiation Estimation and Analysis of Solar Energy: Case Study for Osmaniye, Turkey.” *International Journal of Green Energy* 14(9):765–73.
- Yanıktepe, B. Kara, O. and Kısakürek Parlak, T. 2021. “Enerji Tüketimi ve Ekonomik Büyüme İlişkisi: Türkiye.” *Osmaniye Korkut Ata Üniversitesi Fen Bilimleri Enstitüsü Dergisi* 4(3):452–65.



## VIETNAM'S POLICY ON CO<sub>2</sub> EMISSIONS IN THE CONTEXT OF ACCESSING INTERNATIONAL AGREEMENTS

**Dr. Le Thi Minh**

Thu Dau Mot University

### ABSTRACT

Participating in the international market through bilateral and multilateral FTAs contributes to Vietnam's outstanding achievements in economic development. However, high economic growth also causes Vietnam to emit a large amount of CO<sub>2</sub> into the atmosphere. Reducing CO<sub>2</sub> emissions in the context of trade opening is a matter of particular importance, having significant influence, interacting, and deciding the country's sustainable development; is the basis and premise for making guidelines and policies for socio-economic development, ensuring national defense, security, and social security. The article presents the situation of CO<sub>2</sub> emissions in Vietnam over the years. At the same time, the report studies Vietnam's policy related to CO<sub>2</sub> emissions. On that basis, the paper proposes some recommendations related to the implementation of policies on CO<sub>2</sub> emissions.

**Keywords:** CO<sub>2</sub> emission, CO<sub>2</sub> emission policy, carbon credit market

### 1. Introduction

At COP26, Vietnam and 146 countries have committed to (i) bringing net emissions to "zero" by 2050, (ii) reducing methane emissions by 30% by 2030, and (iii) fighting forest degradation and transforming clean energy exchange. A series of challenges were posed, but Vietnam has the foundation to realize this goal. This is because Vietnam still has a lot of potentials to reduce emissions. According to calculations by the Ministry of Natural Resources and Environment, Vietnam can reduce the amount of methane by 22% through an internal force. In addition, a series of afforestation projects implemented in recent years is compelling. Vietnam also signed a carbon credit exchange and the initial preparation for forming a carbon market. From 2011 to now, many laws, strategies, and policies on climate change have been promulgated. The Law on Environmental Protection in 2020 has a chapter on responding to climate change. Responding to climate change has moved to a new stage, requiring Vietnam to deeply and substantively participate in global efforts.

### 2. Research Methods

This article is based on: (i) an Analysis of documents, reports, and data on the situation of CO<sub>2</sub> emissions in Vietnam by Vietnamese state agencies and research agencies such as the Ministry of Natural Resources and Environment, School, National Center for Socio-Economic Information and Forecast (under the Ministry of Planning and Investment), Steering Committee for the Implementation of the United Nations Framework Convention on Climate Change, and the Kyoto Protocol in Vietnam; (ii) Legal reports, research articles in relevant journals, and the Internet; (iii) Legal documents issued by competent state agencies of Vietnam related to environmental protection in general and greenhouse gas emission reduction in particular.

The author reviewed the literature and consulted with experts to determine the contents of Vietnam's situation and policies related to CO<sub>2</sub> emissions.

### 3. The situation of CO<sub>2</sub> emissions in Vietnam over the years

Table 1. Greenhouse gas emissions in 2000, 2010, 2013, 2014 and 2020<sup>1</sup>

Unit: million tons of CO<sub>2</sub>

Field/year	2000	2010	2013	2014	2020
Energy	52.8	141.1	151.4	171.62	347.5
Industrial processes	10.0	21.2	31.8	38.62	80.5
Agriculture	65.1	88.3	89.4	89.75	104.5
LULUCF	15.1	-19.2	-34.2	-37.54	-35.4
Waste	7.9	15.4	20.7	21.54	31.3
<b>Total</b>	<b>150.9</b>	<b>246.8</b>	<b>259.0</b>	<b>321.5</b>	<b>563.8</b>

CO<sub>2</sub> emissions were 63% from 150.9 million tons in 2000 to 246.8 million tons in 2010. However, the CO<sub>2</sub> emission level in 2010-2020 was twice as fast as in the previous decade. Specifically, the growth rate of CO<sub>2</sub> emissions reached 128.4%, increasing from 246.8 million tons in 2010 to 563.8 million tons in 2020. The period 2010-2020 is the period when Vietnam opens up. Extensive trade to 200% with the successful conclusion of important bilateral and multilateral FTAs. This contributes to GDP growth as well as solid developments in economic sectors. However, the issue of environmental protection has yet to be focused on due to the promotion of industrialization, causing increased CO<sub>2</sub> emissions at a high rate.

In 2020, in the fields with GHG emissions, the rate of GHG emissions in the energy sector (including transportation activities) was the largest, accounting for 62%, followed by agriculture accounting for 18%; Industrial processes and product consumption make up 14% and waste 5% (MPI, UNDP, USAID 2022). The table above shows GHG emissions/removals by sector for 2000-2020. Accordingly, the total amount of GHG (including land use, land use change, and forestry) has increased more than 3.7 times, from 150.9 million tons of CO<sub>2</sub> equivalent to 563,8 million tons of CO<sub>2</sub>. In particular, the amount of emissions in the energy sector has increased significantly, about 6.5 times higher than in 2000, due to the rapidly growing demand for energy.

The emission situation in each sector of Vietnam is as follows:

#### Firstly, the emission situation in the energy industry

In the energy sector in Vietnam, GHGs are mainly emitted from fuel combustion and released during the extraction and transportation of power. Emissions have increased rapidly over the years, from 121.9 million tons of CO<sub>2</sub>e (in 2010) to 347.5 million tons of CO<sub>2</sub> (in 2020). Accordingly, from 2010-2020, CO<sub>2</sub> emissions increased by more than 2.8 times.

Table 2. GHG emissions by energy source in 2014 and 2020:<sup>2</sup>

The source	Amount of emissions (Unit: Million tons)		Ratio to total industry emissions (%)	
	2014	2020	2014	2020
Manufacturing and construction industry	49.4	72.0	28.8	20.7
Transportation	30.5	47.0	17.8	13.5
Household, agricultural and commercial services	16.3	21.0	9.5	6.0
Energy industry	75.4	207.5	43.9	59.7
<b>Total</b>	<b>171.6</b>	<b>347.5</b>	-	-

<sup>1</sup> Nguyen Van Hieu, Nguyen Hoang Nam (2021), "Scientific report: Current status of greenhouse gas emissions in Vietnam: Opportunities and challenges" - *Hydrometeorological Journal, Numbers 6, 51-66*.

<sup>2</sup> Ministry of Natural Resources and Environment (2020), *Viet Nam's biennial update report to the United Nations Framework Convention on Climate Change*, [http://www.dcc.gov.vn/kien-thuc/1084/Bao-cao-cap-nhat-hai-nam-mot-lan-lan-thu-ba-cua-Viet-Nam-\(BUR3\)-gui-cong-convention-framework-Lien-hop-quoc-ve-bien-doi-khi-hau.html](http://www.dcc.gov.vn/kien-thuc/1084/Bao-cao-cap-nhat-hai-nam-mot-lan-lan-thu-ba-cua-Viet-Nam-(BUR3)-gui-cong-convention-framework-Lien-hop-quoc-ve-bien-doi-khi-hau.html).



CO<sub>2</sub> emissions in the energy industry in 2020 will double to 347.5 million tons of CO<sub>2</sub>e from 171.6 million tons of CO<sub>2</sub> in 2014. The energy industry accounts for the largest market share, with 43.9% in 2014, and continues to be the highest emission industry, with a rate of 59.7% in 2020. The main reason is that the industry consumes a lot of fossil energy.

### Secondly, the emission situation in the Industrial processes and products.

For industrial processes and products, the main types of industrial production generating GHGs are cement, lime, ammonium, iron, and steel. Total GHG emissions in industrial output in 2020 increased sharply to 80.5 million tons of CO<sub>2</sub> from 38.6 million tons of CO<sub>2</sub> in 2014. The mining industry accounted for the largest market share, accounting for 35.2% in 2014 and 53.1 in 2020. This is because the heating of limestone produces CO<sub>2</sub> directly, while burning fossil fuels to heat the kiln indirectly leads to CO<sub>2</sub> emissions. This energy-intensive industry has a lot of emissions due to its extreme heat requirements.

Table 3. GHG emissions by industry emission source in 2014 and 2020:<sup>3</sup>

The source	Amount of emissions (Unit: Million tons)		Ratio to total industry emissions (%)	
	2014	2020	2014	2020
Mining industry	35.20	53.10	91.19	65.96
Chemical industry	1.70	3.20	4.40	3.97
Metallurgical industry	1.70	24.20	4.40	30.06
<b>Total</b>	<b>38.60</b>	<b>80.50</b>	-	-

### Thirdly, the emission situation in the Agriculture

According to the results of the GHG inventory in 2014 of the Ministry of Natural Resources and Environment, the amount of GHG emissions in the agricultural sector is 89.75 million tons of CO<sub>2</sub>, accounting for 28% of the total GHG emissions of the country. By 2020, the amount of GHG emissions in the agricultural sector will be 104.5 million tons of CO<sub>2</sub>, accounting for 32.5% of the total GHG emissions. The rice cultivation and agricultural land sectors emit the most, accounting for 40% and nearly 28% of the total emissions in the agricultural sector in 2020 (Table 5), respectively. Rice farming is the most significant contributor to total GHG emissions in the agricultural industry as it is a powerful emitter of methane (CH<sub>4</sub>) and nitrous oxide (N<sub>2</sub>O).

Table 4. GHG emissions by the source of agricultural emissions in 2014 and 2020:<sup>4</sup>

The source	Amount of emissions (Unit: Million tons)		Ratio to total industry emissions (%)	
	2014	2020	2014	2020
Digest food	10.2	18.8	11.4	18.0
Waste management	8.9	12.1	9.9	11.6
Rice cultivation	44.3	41.9	49.3	40.1
Agricultural land	24.0	29.3	26.7	28.0
Burning grasslands	0.0	0.0	0.0	0.0
Burning agricultural by-products in the field	2.4	2.4	2.7	2.3
<b>Total</b>	<b>89.80</b>	<b>104.50</b>		

<sup>3</sup>Ministry of Natural Resources and Environment (2020), *Viet Nam's biennial update report to the United Nations Framework Convention on Climate Change*, [http://www.dcc.gov.vn/kien-thuc/1084/Bao-cao-cap-nhat-hai-nam-mot-lan-lan-thu-ba-cua-Viet-Nam-\(BUR3\)-gui-cong-convention-framework-Lien-hop-quoc-ve-bien-doi-khi-hau.html](http://www.dcc.gov.vn/kien-thuc/1084/Bao-cao-cap-nhat-hai-nam-mot-lan-lan-thu-ba-cua-Viet-Nam-(BUR3)-gui-cong-convention-framework-Lien-hop-quoc-ve-bien-doi-khi-hau.html).

<sup>4</sup>Ministry of Natural Resources and Environment (2020), *Viet Nam's biennial update report to the United Nations Framework Convention on Climate Change*, [http://www.dcc.gov.vn/kien-thuc/1084/Bao-cao-cap-nhat-hai-nam-mot-lan-lan-thu-ba-cua-Viet-Nam-\(BUR3\)-gui-cong-convention-framework-Lien-hop-quoc-ve-bien-doi-khi-hau.html](http://www.dcc.gov.vn/kien-thuc/1084/Bao-cao-cap-nhat-hai-nam-mot-lan-lan-thu-ba-cua-Viet-Nam-(BUR3)-gui-cong-convention-framework-Lien-hop-quoc-ve-bien-doi-khi-hau.html).

### *Fourthly, the emission situation in Land use, land use change, and forestry.*

Land use, land use change, and forestry have gradually shifted from GHG emission to GHG sequestration since 2010. GHG emissions in this sector increased to 110.7 million tons of CO<sub>2</sub> in 2020 from 5.4 million tons of CO<sub>2</sub> in 2014. In comparison, GHG absorption rose from 42.9 million tons of CO<sub>2</sub> in 2014 to 146.1 million tons of CO<sub>2</sub> in 2020, in which forest land and arable land are absorption sources.

*Table 5. GHG emissions by the source of emissions in the field of land use, land use change, and forestry in 2014 and 2020 (unit: Million tons):<sup>5</sup>*

Source of Emission/Absorption	2014	2020
Absorb	-42.9	-146.1
Emissions	5.4	110.7
Total	-37.5	-35.4

### **Lastly, the emission situation in the Waste.**

In Vietnam, in recent years, every year, more than 15 million tons of solid Waste are discharged from different sources. However, only over 70% of solid Waste in urban areas and about 20% in rural areas is collected and treated. While the GHG emissions of this sector mainly include: CH<sub>4</sub> emissions from collected solid waste landfills; industrial wastewater and domestic wastewater; N<sub>2</sub>O emissions from domestic sewage sludge; CO<sub>2</sub> and N<sub>2</sub>O emissions from waste incineration. In general, emissions from the waste sector account for a small proportion. The total GHG emissions of this sector in 2014 were 21.5 million tons of CO<sub>2</sub> (accounting for 6.6% of the total emissions of the country), increasing to 31.3 million tons of CO<sub>2</sub> in 2020, accounting for 5.5% in the structure of the total national emissions. Urban wastewater has the largest share of GHG emissions, accounting for 44.7% in 2014, and Solid Waste landfilling accounts for the most significant proportion of GHG emissions at 38% in 2020.

*Table 6. GHG emissions by waste industry emission source in 2014 and 2020:<sup>6</sup>*

The source	Amount of emissions (Unit: Million tons)		Ratio to total industry emissions (%)	
	2014	2020	2014	2020
Solid waste burial	8.0	11.9	37.2	38.0
Industrial wastewater treatment	1.6	4.4	7.4	14.1
Domestic wastewater treatment	9.6	10.6	44.7	33.9
Emissions from human Waste	2.0	2.4	9.3	7.7
Solid waste incineration	0.3	1.8	1.4	5.8
Composing	N/A	0.2	N/A	0.6
Total	21.5	31.3	-	-

## **4. Vietnam's international commitments related to CO<sub>2</sub> reduction**

### **4.1. General international agreements**

The Government of Vietnam has signed international conventions on the global response to climate change, specifically as follows: (i) Signed the United Nations Framework Convention on Climate Change in 1992 and

<sup>5</sup>Ministry of Natural Resources and Environment (2020), Viet Nam's biennial update report to the United Nations Framework Convention on Climate Change, [http://www.dcc.gov.vn/kien-thuc/1084/Bao-cao-cap-nhat-hai-nam-mot-lan-lan-thu-ba-cua-Viet-Nam-\(BUR3\)-gui-cong-convention-framework-Lien-hop-quoc-ve-bien-doi-khi-hau.html](http://www.dcc.gov.vn/kien-thuc/1084/Bao-cao-cap-nhat-hai-nam-mot-lan-lan-thu-ba-cua-Viet-Nam-(BUR3)-gui-cong-convention-framework-Lien-hop-quoc-ve-bien-doi-khi-hau.html).

<sup>6</sup>Ministry of Natural Resources and Environment (2020), Viet Nam's biennial update report to the United Nations Framework Convention on Climate Change, [http://www.dcc.gov.vn/kien-thuc/1084/Bao-cao-cap-nhat-hai-nam-mot-lan-lan-thu-ba-cua-Viet-Nam-\(BUR3\)-gui-cong-convention-framework-Lien-hop-quoc-ve-bien-doi-khi-hau.html](http://www.dcc.gov.vn/kien-thuc/1084/Bao-cao-cap-nhat-hai-nam-mot-lan-lan-thu-ba-cua-Viet-Nam-(BUR3)-gui-cong-convention-framework-Lien-hop-quoc-ve-bien-doi-khi-hau.html).

ratified it in 1994; (ii) Signing of the Kyoto Protocol in 1998 and ratification of the Kyoto Protocol in 2002 and (iii) Signing and ratification of the Paris Agreement on Climate Change in 2016.

In particular, the Paris Agreement on climate change, adopted at the 21st Conference of the Parties (COP21), is the first global legal document binding all Parties' responsibility to ratify the "Contributions to climate change." Intended Nationally Determined" (INDC).

Thus, from a country that is not bound by the responsibility to reduce greenhouse gases (not included in Annex I of the United Nations Framework Convention on Climate Change), Vietnam must fulfill the obligation to contribute to reducing greenhouse gas emissions. GHG emissions mitigation proposed in the Nationally Determined Contribution to take advantage of the opportunity to develop a low-carbon economy.

Vietnam's commitments at the 26th Conference of the United Nations Framework Convention on Climate Change (COP26). Commitment and participation with the international community in responding to climate change, reducing carbon emissions, and sustainable development is an inevitable trend in the international community's determination to promote green and economic development.

In addition, Vietnam is committed to developing and implementing measures to reduce greenhouse gas emissions to achieve net emissions of "0" (referred to as Net Zero) by 2050, reducing emissions by 30% of greenhouse gas methane by 2030, focusing on the following 08 essential tasks; (i) switch from fossil energy to green energy, clean energy; (ii) reduce greenhouse gas emissions in industries and fields; (iii) reducing methane emissions, especially in agricultural production and waste treatment; (iv) encouraging research, development, and use of electric cars; (v) sustainable management and use of existing forest areas, while promoting new afforestation to absorb and store carbon; (vi) research, production, use of building materials and urban development in accordance with green and sustainable development; (vii) promote and innovate communication work so that the whole people and business community are unified in awareness and accompany the Government in implementing commitments at COP26; (viii) promote the digital transformation to respond to climate change.

Accordingly, the development orientation of crucial industries and fields, such as energy, will improve efficiency and use efficiency; reduce energy consumption in production, transportation, commerce, and industry. They also ensure energy security, synchronous development, efficient exploitation and use of energy sources, restructuring energy sources, reducing dependence on fossil energy, and increasing the proportion of renewable and new energy sources in energy production and consumption. Green economic and production sectors will gradually limit the generation of large wastes, causing pollution and environmental degradation; develop green technology and management systems; control production activities according to best practices to save resources, reduce emissions, and improve the ecological environment.

#### **4.2. Environmental commitments in traditional FTAs**

The environmental content in the FTAs is scattered in the preamble or the provisions related to the environment. Environmental commitments in some traditional FTAs such as:

- Commitment to the environment in ASEAN:

*Regarding tariffs:* In the regulation, the list of general exclusions related to the environment is specified, including products necessary for protecting flora and fauna and endangered natural resources. The exclusion from the ASEAN Trade in Goods Agreement of these products is consistent with the GATT Agreement on general exceptions, including exceptions for environmental protection.

*Regarding non-tariff measures:* Environmental services have been included in the commitments since the Framework Agreement on Trade in Services signing in 1995.<sup>7</sup>

- Commitment to the environment in the Asia-Pacific Economic Cooperation (APEC) Forum.

---

<sup>7</sup> ASEAN Framework Agreement on Services (AFAS) was signed on 15/12/1995, <https://aecvcci.vn/Uploaded/Users/banthuky/files/2020/ATISA-signed-scanned.pdf>, last accessed on December 27, 2022.

Sustainable development has always been the top goal of APEC, so there are many cooperation programs in APEC, directly and indirectly, related to the environment: Fisheries development cooperation program; Conservation and development of marine resources; Sustainable Development; Biotechnology; environmental goods, cleaner production, sustainable supply chains, sustainable cities...

*Environmental goods:* APEC is currently the first international economic cooperation to successfully achieve the commitment to cut taxes on ecological goods. In 2012, leaders of 21 APEC countries agreed to sign an agreement to reduce voluntary import tax on 54 environmental goods with a period of effect from December 2015.

*Cleaner production:* APEC promotes the broader application of interdisciplinary policies and methods toward cleaner production through the cooperation of the institutional, professional, public, and private sectors.

- Environmental commitments in the Asia-Europe Summit.

The Asia-Europe Summit has many cooperation programs to promote environmental protection activities through seminars, investment promotion programs, capacity-building support, and the establishment of financial institutions, mainly to support investment.

- Agreement on technical trade barriers.

This Agreement has about 11% related to the environment. The environmental measures to be notified include measures to limit pollution, waste management, energy conservation, efforts to conserve natural resources, and steps to implement multilateral agreements in the environmental aspect. The major trade-environmental issues related to the application of technical requirements in international trade under this Agreement include:

*Eco-labels:* E-labels are becoming increasingly widespread and complex, which may hinder exports from developing and underdeveloped countries. The problem is that ecolabelling programs are often based on analyzing only a few aspects related to the product life cycle, and therefore importing countries often have different criteria for ecolabelling.

*Manufacturing and Processing Methods (PPMs):* WTO Members agree that import measures may be based on production methods and processes if such production methods or techniques constitute a particular characteristic of product properties. However, developing countries oppose the application of import measures based on *unrelated production methods and processes* and the use of criteria that are "discriminatory" between the two countries.

*Packaging Requirements:* Some countries put packaging requirements on imported goods, for example, type of packaging, reusability, recyclability, or compostability. These requirements create additional costs for exporters and threaten to impede export market access. In practice, these requirements can be applied "discriminatory" or manipulated by domestic corporations claiming protection.

### 4.3. Environmental commitments in the new generation FTAs (CPTPP and EVFTA)

- CPTPP Agreement:

CPTPP is the first multilateral FTA to include environmental issues as a chapter of commitments. The content of such obligations is aimed at promoting mutual support between trade policies and the environment, supporting countries with appropriate measures to promote environmental protection activities further, and limiting the exhausting exploitation of natural resources. Additionally, it encourages trade liberalization in goods and services to support the transition to a green and low-carbon economy. However, environmental commitments are still relatively "shy" and are looking for "first steps." The contents of the new obligations only stop at pointing out problems and calling on countries to work together to solve them. Still, there are no specific commitments, such as giving tax reduction figures, years of market opening, and participation.

The content of environmental provisions can be divided into two groups: (i) *The first group* includes goods and services that support and contribute to the implementation of green growth and a low-carbon economy, with policies on tax reduction, trade barriers, and cooperation through bilateral and multilateral projects and promote investment among the parties but there are no deeper commitments on tax reduction or other commitments; (ii) *The second group* includes content on limiting pollution and resource depletion due to

commercial activities. This group focuses on biodiversity, conservation, voluntary environmental enforcement mechanisms, ozone layer protection, and alien organisms. The content is mainly about calling for cooperation to protect, restrict, and prohibit commercial activities for these activities.

There are all 30 chapters in the CPTPP, of which Chapter 20 on the Environment includes 23 articles, which can be divided into 04 main contents. The most critical group includes provisions on environmental issues—, including 11 terms.<sup>8</sup>

- EVFTA Agreement:

The EVFTA is considered the most comprehensive FTA in Vietnam, furthering its commitment to sustainable development in an FTA. The two sides have agreed to sign a separate chapter on sustainable commercial development, including environmental issues.

There are 17 articles in the commitment chapter on trade and sustainable development, which emphasize the right of each party to develop a system of laws and standards to ensure sustainable development. The contents of environmental commitments include Multilateral environmental obligations, responsibilities on climate change, duties on biodiversity, commitments on sustainable forest management and trade in products forest products, a commercial dedication to sustainable management of marine resources and fishery products, and a commitment to trade and investment in a sustainable manner.<sup>9</sup>

### 5. Vietnam's policy on reducing CO<sub>2</sub> emissions

#### 5.1. Legal basis

*Vietnam has issued a series of legal documents to implement policies on reducing greenhouse gas emissions, specifically:*

- Clause 1, Article 63 of Chapter III of the 2013 Constitution of the Socialist Republic of Vietnam mentioned the content of responding to climate change;<sup>10</sup>
- The Law on Environmental Protection 2014 has devoted Chapter IV to separate provisions on response to climate change. Contents on the management of greenhouse gas emissions are specified in Point 1, Article 41;<sup>11</sup>
- The Prime Minister approved the National Action Plan on Climate Change in Decision No. 1474/QĐ-TTg, dated October 5, 2012, with the objective of “Mitigating GHG emissions, developing the economy according to the low-carbon direction” to “implement GHG emission mitigation measures for production activities, suitable to Vietnam's conditions.”<sup>12</sup>
- The Prime Minister issued Decision No. 1803/QĐ-TTg dated October 22, 2015, to strengthen the capacity of formulating, implementing, and disseminating policies and tools of state management for reducing mild greenhouse gas emissions in line with national conditions.<sup>13</sup>

<sup>8</sup>Chapter 20, CPTPP Agreement, link [http://cptpp.moit.gov.vn/data/e0593b3b-82bf-4956-9721-88e51bd099e6/userfiles/files/20\\_%20Environment.pdf](http://cptpp.moit.gov.vn/data/e0593b3b-82bf-4956-9721-88e51bd099e6/userfiles/files/20_%20Environment.pdf), last accessed on 27/12/2022.

<sup>9</sup>EVFTA Agreement, link <https://ngkt.mofa.gov.vn/toan-van-hiep-dinh-thuong-mai-viet-nam-lien-minh-chau-au-evfta/>, last accessed on 27/12/2022.

<sup>10</sup> National Assembly (2013), *Constitution of the Socialist Republic of Vietnam*, [https://moj.gov.vn/vbpq/lists/vn%20bn%20php%20lut/view\\_detail.aspx?itemid=28814](https://moj.gov.vn/vbpq/lists/vn%20bn%20php%20lut/view_detail.aspx?itemid=28814), access as of December 27, 2022.

A) <sup>11</sup> National Assembly (2020), *Law on Environmental Protection, Law No. 72/2020/QH14*, <https://vanban.chinhphu.vn/?pageid=27160&docid=202613&classid=1&typegroupid=3>, nearest access December 27, 2022.

B) <sup>12</sup> Prime Minister (2012), *Decision No. 1474/QĐ - TTg of the Prime Minister Government: On the promulgation of the National Action Plan Information on climate change for the period 2012 – 2020*,

C) <https://vanban.chinhphu.vn/default.aspx?pageid=27160&docid=164069>,

D) last accessed on December 27, 2022.

E) <sup>13</sup> Prime Minister (2015), *Decision No. 1803 / QĐ - TTg of the Government: Approving the list of technical assistance projects "Standard ready to build a carbon market in Vietnam," sponsored by the World Bank*,

F) <https://vanban.chinhphu.vn/default.aspx?pageid=27160&docid=181878>,

G) last accessed 12/27/2022.

- The Prime Minister issued Directive No. 35/2005/CT-TTg, dated October 17, 2005, on organizing the implementation of the Kyoto Protocol under the United Nations Framework Convention on Climate Change;<sup>14</sup>
- The Prime Minister issued Decision No. 130/2007/QĐ-TTg dated August 2, 2007, of the Prime Minister on several financial mechanisms and policies for investment projects under the Clean Development Mechanism.<sup>15</sup>
- The Prime Minister issued Decision No. 1474/QĐ-TTg dated October 5, 2012. This decision approves the national action plan on climate change for 2012-2020. Mitigating greenhouse gas emissions and developing a low-carbon economy are identified as criteria. five critical tasks of this plan;<sup>16</sup>
- The Prime Minister issued Decision 2359/QĐ-TTg dated 22/12/2015, approving the national greenhouse gas inventory system. This decision has created a legal and technical foundation for implementing the nationwide GHG inventory.<sup>17</sup>
- The Prime Minister issued Decision No. 985a/QĐ-TTg dated June 1, 2016, approving the national action plan on air quality management up to 2020, with a vision to 2025;<sup>18</sup>
- The Prime Minister issued Decision 2053/QĐ-TTg on October 28, 2016, approving the plan to implement the Paris Agreement on climate change. This decision specified Vietnam's commitments to the international community in responding to climate change. It simultaneously fulfilled its obligations to Vietnam in the Paris agreement, identifying five groups of tasks with two specific implementation phases (2016-2020 and 2021-2030).<sup>19</sup>
- The Prime Minister issued Decision No. 1658/QĐ-TTg dated October 1, 2021, on the National Strategy on Green Growth in the 2021 - 2030 period, with a vision to 2050. The green growth target promotes economic restructuring associated with growth model innovation. Green growth to achieve economic prosperity, environmental sustainability, and social equity; towards a green, carbon-neutral economy and contribute to the goal of limiting global temperature rise.<sup>20</sup>

### 5.2. Plan to promote the carbon market

After the commitment at COP26, the Government issued Decree 06/2022/ND-CP regulating the mitigation of greenhouse gas emissions and the protection of the ozone layer.<sup>21</sup> This Decree details several articles of the

H) <sup>14</sup> Prime Minister (2015), Directive No. 35/2005/CT - TTG of the Prime Minister of the Government: Directing the implementation of the Decree No. 35/2005 /CT - TTG, <https://chinhphu.vn/default.aspx?pageid=27160&docid=14924>, last accessed 12/27/2022.

i) <sup>15</sup> Prime Minister (2007), Decision No. 130/2007/QĐ-TTg of the Prime Minister Government: On several financial mechanisms and policies, check out the id of the first project according to the development mechanism,

j) <https://chinhphu.vn/default.aspx?pageid=27160&docid=35676>,

K) last accessed 12/27/2022.

l) <sup>16</sup> Prime Minister (2012), Decision No. 1474 /QĐ-TTg of the Prime Minister Government: On the promulgation of the National Action Plan expert on climate change for the period 2012 – 2020

m) <https://vanban.chinhphu.vn/default.aspx?pageid=27160&docid=164069>,

N) last accessed on 27/ 12/2020.

o) <sup>17</sup> Prime Minister (2015), Decision No. 2359 / QĐ - TTg of the Prime Minister Government: Approving the National System of List of greenhouse gases, link <https://vanban.chinhphu.vn/default.aspx?pageid=27160&docid=182842> ,

P) last accessed on 7/12/2020.

q) <sup>18</sup> Prime Minister (2016), Decision No. 985a / QĐ - TTg of the Prime Minister Government: On the approval of the action plan system National on air quality management until 2020 with a vision to 2025, <https://chinhphu.vn/default.aspx?pageid=27160&docid=184944> ,

R) last accessed 12/27/2022.

<sup>19</sup> Prime Minister (2016), Decision 2053/QĐ-TTg on promulgating the plan to implement the Paris Agreement on climate change, <http://sotnmt.namdinh.gov.vn/vi-vn/van-ban/moi-truong-71/quyet-dinh-2053-qd-ttg-ve-viec-ban-hanh-ke-hoach-thuc-hien-thoathuan-paris-ve-bien-doi-khi-hau/> 242, last accessed on December 27, 2022.

s) <sup>20</sup> Prime Minister ( 2021 ), Decision No. 1658/QĐ - TTg of the Government: Approving the National Budget on Green growth for 2021-2030, vision to 2050, <https://chinhphu.vn/?pageid=27160&docid=204226&tagid=6&type=1> ,

T) last accessed 12/27/2022.

u) <sup>21</sup> Government (2022), Decree Decree No. 06/2022/ND-CP of the Government: Regulations on mitigating greenhouse gas emissions and ozone pollution,

v) <https://vanban.chinhphu.vn/?pageid=27160&docid=205039>,

Law on Environmental Protection, including Article 91 on the mitigation of greenhouse gas emissions, Article 92 on the protection of the ozone layer, and Article 139 on the organization and development of the carbon market.

The Decree specifies the development roadmap and time to deploy the domestic carbon market. Specifically, the period until the end of 2027:

- Develop regulations on the management of carbon credits, exchange of greenhouse gas emission quotas, and carbon credits; develop rules on the operation of carbon credit trading floors.
- Implement a pilot mechanism for exchanging and clearing carbon credits in potential fields and guide the implementation of the domestic and international carbon credit exchange and clearing mechanism by the law and regulations and international treaties to which the Socialist Republic of Vietnam is a signatory.
- Establish and organize a pilot operation of a carbon credit exchange from 2025.
- Implement activities to strengthen capacity and raise awareness about carbon market development.

The period from 2028:

- Organizing the operation of the official carbon credit exchange in 2028.
- They are regulating activities to connect and exchange domestic carbon credits with regional and global carbon markets.

### - **Exchange of carbon credits on the domestic carbon market.**

The Decree also stipulates the exchange of greenhouse gas emission quotas and carbon credits on the domestic carbon market. Specifically, the business of greenhouse gas emission quotas and carbon credits is carried out on the carbon credit exchange and domestic carbon market according to the following regulations:

- Greenhouse gas emission quotas specified in Clause 2 Article 12 are traded on the exchange. One unit of greenhouse gas emission quota equals 1 ton of CO<sub>2</sub> equivalent.
- Carbon credits obtained from programs and projects under the exchange mechanism and clearing carbon credits can be converted into clearing units for greenhouse gas emission quotas on the trading floor. One carbon credit is equal to 1 ton of CO<sub>2</sub> equivalent.
- Facilities can auction to own more greenhouse gas emission quotas and the amount allocated in the same commitment period. Establishments can transfer the unused greenhouse gas emission quotas in the previous year to subsequent years in the same commitment period. Facilities can borrow GHG emission quotas allocated for the following year to use in the earlier year of the same commitment period.

Establishments can use carbon credits from projects under carbon credit offsets to offset GHG emissions in excess of their allotted GHG emission quotas over a period. The number of carbon credits for offsetting can be at most 10% of the total GHG emissions quota allocated to the establishment.

The allocated GHG emission quotas will be automatically recovered by the Ministry of Natural Resources and Environment when the facilities cease operation, dissolve or go bankrupt. The State encourages establishments to voluntarily pay the unused GHG emission quotas, contributing to the achievement of the national target of mitigating greenhouse gas emissions.

At the end of each commitment period, facilities must pay for the amount of greenhouse gas emissions over the allocated GHG emission quotas after applying the forms of auction, transfer, and borrow, using carbon credits to offset. In addition to payment, GHG emissions above the allocated quota will be deducted from the allocation quota for the subsequent commitment period.

Also, in this roadmap, at the beginning of 2022, the Government issued a list of fields and establishments that must carry out a greenhouse gas inventory according to Decision No. 01/2022/QĐ-TTg. Sectors subject to an inventory include energy and industrial processes (1662 facilities), transportation (70 facilities), construction

---

W) last accessed on December 27, 2022.

(104 facilities), and Waste (76 facilities). This is an essential basis for completing the legal corridor of the GHG emission monitoring system and MRV (measurement, report, appraisal) at the national, sector, sub-sectoral, and one-manufacturing establishments. Thereby, the Government's determination to implement the goal of reducing carbon emissions, responding to climate change, and harmonizing economic development and the environment.

## 6. Reviews and recommendations

Vietnam needs to review and consolidate its commitments and strategies for combating climate change into a complete legal framework and develop a Law on Climate Change. This helps create the legal framework to issue regulations on the emission trading market in Vietnam. At the same time, it is necessary to build a specialized agency with full authority to regulate the market transparently and flexibly.

In addition, it is necessary to have comprehensive calculations and statistics for products/goods that have an impact on the environment or products/goods that cause pollution at the moment but have no substitute products. This is done to provide a reasonable tax rate, ensuring the competitiveness and stability of these items. In the short term, the tax rate of 0% can be applied, or there are preferential policies, tax reductions, and tax exemptions to create an appropriate roadmap, helping taxpayers gradually adapt to this tax. Adding more products and goods that will cause environmental pollution when used is necessary. At the same time, develop a practical roadmap for expanding taxable objects to suit the country's economic development level and taxpayers' financial capacity.

Besides, Vietnam needs to seize the opportunities related to joining FTAs and global value chains to promote green growth in all its export products. Agreements such as the EVFTA Agreement and the CPTPP Agreement have environmental commitments of all members on export trade practices.

Legally, Vietnam needs to complete the legal provisions related to CO<sub>2</sub> emissions. Although constantly being improved, the law on environmental protection still has shortcomings and limitations. It is necessary to review technical regulations on the environment, issue guiding documents, and continuously amend and supplement to develop standards and sanctions more suitable to the situation.

## REFERENCES:

1. ASEAN Framework Agreement on Services (AFAS) was signed on 15/12/1995, <https://aecvcci.vn/Uploaded/Users/banthuky/files/2020/ATISA-signed-scanned.pdf>, last accessed on December 27, 2022.
2. CPTPP Agreement, link [http://cptpp.moit.gov.vn/data/e0593b3b-82bf-4956-9721-88e51bd099e6/userfiles/files/20\\_Environment.pdf](http://cptpp.moit.gov.vn/data/e0593b3b-82bf-4956-9721-88e51bd099e6/userfiles/files/20_Environment.pdf), last accessed on 27/12/2022.
3. EVFTA Agreement, link <https://ngkt.mofa.gov.vn/toan-van-hiep-dinh-thuong-mai-viet-nam-lien-minh-chau-au-evfta/>, last accessed on 27/12/2022.
4. Government (2022), Decree No. 06/2022/NĐ-CP of the Government: Regulations on mitigating greenhouse gas emissions and ozone pollution, <https://vanban.chinhphu.vn/?pageid=27160&docid=205039>, last accessed on December 27, 2022.
5. Nguyen Van Hieu, Nguyen Hoang Nam (2021), “Scientific report: Current status of greenhouse gas emissions in Vietnam: Opportunities and challenges” - *Hydrometeorological Journal, Numbers 6, 51-66*.
6. Ministry of Natural Resources and Environment (2020), *Viet Nam's biennial update report to the United Nations Framework Convention on Climate Change*, [http://www.dcc.gov.vn/kien-thuc/1084/Bao-cao-cap-nhat-hai-nam-mot-lan-lan-thu-ba-cua-Viet-Nam-\(BUR3\)-gui-cong-convention-framework-Lien-hop-quoc-ve-bien-doi-khi-hau.html](http://www.dcc.gov.vn/kien-thuc/1084/Bao-cao-cap-nhat-hai-nam-mot-lan-lan-thu-ba-cua-Viet-Nam-(BUR3)-gui-cong-convention-framework-Lien-hop-quoc-ve-bien-doi-khi-hau.html).
7. National Assembly (2013), *Constitution of the Socialist Republic of Vietnam*, [https://moj.gov.vn/vbpq/lists/vn%20bn%20php%20lut/view\\_detail.aspx?itemid=28814](https://moj.gov.vn/vbpq/lists/vn%20bn%20php%20lut/view_detail.aspx?itemid=28814), access as of December 27, 2022.



8. National Assembly (2020), Law on Environmental Protection, Law No. 72/2020/QH14, <https://vanban.chinhphu.vn/?pageid=27160&docid=202613&classid=1&typegroupid=3> , nearest access December 27, 2022.
9. Prime Minister (2012), Decision No. 1474/QĐ - TTg of the Prime Minister Government: On the promulgation of the National Action Plan Information on climate change for the period 2012 – 2020, <https://vanban.chinhphu.vn/default.aspx?pageid=27160&docid=164069>, last accessed on December 27, 2022.
10. Prime Minister (2015), Decision No. 1803 / QĐ - TTg of the Government: Approving the list of technical assistance projects "Standard ready to build a carbon market in Vietnam," sponsored by the World Bank, <https://vanban.chinhphu.vn/default.aspx?pageid=27160&docid=181878> , last accessed 12/27/2022.
11. Prime Minister (2015), Directive No. 35 /2005/CT - TTG of the Prime Minister of the Government: Directing the implementation of the Decree No. 35/2005 /CT - TTG, <https://chinhphu.vn/default.aspx?pageid=27160&docid=14924>, last accessed 12/27/2022.
12. Prime Minister (2007), Decision No. 130/2007/QĐ-TTg of the Prime Minister Government: On several financial mechanisms and policies, check out the id of the first project according to the development mechanism, <https://chinhphu.vn/default.aspx?pageid=27160&docid=35676>, last accessed 12/27/2022.
13. Prime Minister (2012), Decision No. 1474 /QĐ-TTg of the Prime Minister Government: On the promulgation of the National Action Plan expert on climate change for the period 2012 – 2020, <https://vanban.chinhphu.vn/default.aspx?pageid=27160&docid=164069>, last accessed on 27/ 12/2020.
14. Prime Minister (2015), Decision No. 2359/QĐ - TTg of the Prime Minister Government: Approving the National System of List of greenhouse gases, link <https://vanban.chinhphu.vn/default.aspx?pageid=27160&docid=182842> , last accessed on 7/12/2020.
15. Prime Minister (2016), Decision No. 985a / QĐ - TTg of the Prime Minister Government: On the approval of the action plan system National on air quality management until 2020 with a vision to 2025, <https://chinhphu.vn/default.aspx?pageid=27160&docid=184944> , last accessed 12/27/2022.
16. Prime Minister (2016), Decision 2053/QĐ-TTg on promulgating the plan to implement the Paris Agreement on climate change, <http://sotnmt.namdinh.gov.vn/vi-vn/van-ban/moi-truong-71/quyet-dinh-2053-qd-ttg-ve-viec-ban-hanh-ke-hoach-thuc-hien-thoa-thuan-paris-ve-bien-doi-khi-hau/> 242, last accessed on December 27, 2022.
17. Prime Minister (2021), Decision No. 1658/QĐ - TTg of the Government: Approving the National Budget on Green growth for 2021-2030, vision to 2050, <https://chinhphu.vn/?pageid=27160&docid=204226&tagid=6&type=1> , last accessed 12/27/2022.



## VICTORIA GREEN B PHOTOCATALYTIC DEGRADATION IN WATER

**Assist. Prof. Dr. Rozina Khattak**

Department of Chemistry, Shaheed Benazir Bhutto Women University, Peshawar 25000, Pakistan

### ABSTRACT

This investigation looks on the peroxydisulfate-mediated degradation of the toxic dye i.e., Victoria Green B (VGB). The silver oxide microparticles (MPs) were synthesized using a low-cost, environmentally friendly method. The dye degraded by 80+% in 180 minutes showing that the MPs had high photoactivity. The complete degradation of VGB in 21 minutes was a proof that peroxydisulfate had a significant synergistic effect on the activity of photocatalyst. This method reveals a cost-effective and environmentally benign application of the silver oxide based photocatalytic degradation of cationic dyes in wastewater.

**Keywords:** Photocatalysis, Degradation Kinetics, Solar Radiations



**ENVIRONMENTAL REMEDIATION BY USING WASTE BASED BIOSORPTION OF BASIC GREEN 4 FROM WATER**

**Assist. Prof. Dr. Rozina Khattak**

Department of Chemistry, Shaheed Benazir Bhutto Women University, Peshawar 25000, Pakistan

**ABSTRACT**

Basic Green 4 (BG4) is a hazardous dye both to human and other living organisms. Regardless its toxicity, it is widely used in several industries to dye the goods of common use. When industrial effluents containing this dye and other corresponding dyes are dumped into water resources and soil, they damage the ecosystem and create pollution. In this study, the BG4 dye was removed from the water using the waste material. Most of the dye was removed within 10 minutes at optimized conditions yielding excellent result that can lead to the use of this method for environmental remediation.



### ESTIMATING THE METHANE EMISSION AND ENERGY POTENTIAL FROM BLIDA DUMPSITE BY LandGem MODEL

Toumi Meriem<sup>1</sup>, Abdelli Islem Safia<sup>2</sup>, Abdelmalek Fatiha<sup>2</sup>, Addou Ahmed<sup>2</sup>

<sup>1,2</sup> 27000, Abdelhamid Ibn-Badis University, Mostaganem, Algeria

#### ABSTRACT

One major factor, contributing to the emission of greenhouse gas in the environment, is the generation of hazardous gases in municipal landfills. Due to these potential negative impacts, it is obligatory to estimate the amount and type of landfill gasses to design and build a gas collecting system. Landfill gas emissions are governed by many factors, as the type of waste, its biodegradability, its methane emission potential, the degree of separation, and other miscellaneous factors. In our study, LandGem model was used to predict the amount of gases produced in the landfills of Blida. According to the results, a large amount of CH<sub>4</sub> is released 74.4173 Gg from 2010 to 2021 which attributed to global warming. This loss of energy can be converted into energy and therefore it will allow an autonomous landfill in term of electricity.

**Keywords:** solid waste, energy potential, methane, LandGem.



## CLIMATE CHANGE IMPACT IN PAKISTAN- A REVIEW

**Ishaq Ali Shah<sup>a\*</sup>, Haroon Khan<sup>b</sup>, Zahir Muhammad<sup>a</sup>, Rehman Ullah<sup>a</sup>**

<sup>a</sup>Department of Botany, University of Peshawar, Peshawar 25120, Pakistan

<sup>b</sup>Department of Weed Science and Botany, The University of Agriculture, Peshawar 25130, Pakistan

### ABSTRACT

The Intergovernmental Panel on Climate Change (IPCC) Sixth Assessment Report (AR6) documents the global surface temperature reaching 1.1 °C above 1850-1900 in the last decade (2011-2020). Pakistan is persistently placed in the top ten (bottom ten colloquially) most vulnerable nations in the world by Global Climate Risk Index. To Notre Dame GAIN Index Ranking (2019), Pakistan stands 152<sup>nd</sup> among 181 countries by its vulnerability to climate change and its readiness to improve resilience as reported by World Bank Report. The carbon footprint of Pakistan is the lowest while it is hit by climate change-induced weather extremes like floods, droughts, heatwaves, etc. to the maximum warranting the globe to support the country in mitigating the climate crisis. The aim of the current review is to highlight the losses Pakistan bears to climate change and the response of the globe to act on the issue supporting Pakistan to combat the threat.



### A COMPARATIVE ANALYSIS OF CARBON EMISSIONS AND ECOLOGICAL FOOTPRINTS: THE MODERATING ROLE OF ICT IN THE NATURAL RESOURCE RENT AND ENVIRONMENTAL DAMAGE NEXUS IN BRICS

**Iftikhar Yasin**

Department of Economics, The University of Lahore, Lahore, Pakistan

#### **ABSTRACT**

Due to the detrimental impacts of climate change, economic growth patterns worldwide have had a significant impact on the natural environment during the last three decades. This research attempted to investigate the effect of natural resource rent, ICT, and democracy on the growing economies of Brazil, Russia, India, China, and South Africa (BRICS) from 1990 to 2019. The data's legitimacy was verified using econometric procedures, including the cross-sectional dependency test and the second-generation panel unit root test. Finally, the panel data analysis was performed using the Driscoll-Kraay estimation technique. The results reveal that natural resource rent further deteriorates the environmental eminence by instigating carbon emissions and ecological footprint. However, ICT helps to mitigate the devastating environmental damage but only at lower levels of natural resource rent. The empirical data suggests that ICT is vital to the sustainable development of the BRICS nations. The policymakers are urged to improve ICT to lessen the devastation caused by natural resource rent.

**Keywords:** Natural Resource Rent, ICT, Democracy, Carbon Emissions, Ecological Footprint, BRICS



## WASTE-TO-ENERGY PLANTS: SOURCE OF ENERGY UTILIZING WASTE PRODUCTS

**Dr. Harminder Singh,**

Associate Professor, Department of Mechanical Engineering Guru Nanak Dev University, Amritsar, Punjab-143005, India  
ORCID NO: 0000-0002-0829-2154

### ABSTRACT

Waste – to – energy plants are the source of generation of electrical/thermal energy from the fuel which is considered as waste. This power generation plant has the capability to reduce the waste products and thus produce clean and green energy. These plants are the special category of plants known as waste incinerators. Incineration is an effective method for combustion of waste in developing countries especially where land resources are limited. Agriculture waste such as cotton sticks can be collected from farms and used as fuel in these plants which will generate revenue to farmers. However globally the waste-to-energy plants are running at low efficiency as compared to fossil fuel based plants due to hot corrosion degradation failure of the heat exchanger components. The presence of mainly alkali and heavy metals along-with chlorine in the waste lowers the first melting point (FMT) of deposits on the surfaces, results in accelerated corrosion of the components. Though superalloys show better results compared to different boiler steels but still there is need of corrosion resistant coatings to improve the efficiency of the power plants.

**Keywords:** Electricity, Waste to energy plants, Waste, Efficiency, Boilers

### 1. Introduction

Waste-to-energy plants are the power generation plants utilizing various available waste resources. These plants are the need of the hour to reduce the waste products. One of the various types of methods in the production of energy generation using waste as fuel in power plants instead of coal in thermal power plants. This will solve the problem of decomposing the waste as well as energy shortage worldwide. However, these plants are working at low efficiency as compared to other power plants. The corrosive degradation of plant components is a serious problem which needs to be resolved to enhance their efficiency [1-3]. The hot corrosion of heat resistant alloys, in waste incinerators and other similar environments, accelerates by the presence of mainly chlorine, sulfur and alkali metals in the fuel combustion products or impurities [3]. Therefore, an attempt have been made in this study to enhance the electrical energy efficiency of these plants by increasing the life of the plant components.

### 2. Experimental procedure

The Ni-based superalloy (12Fe-23Cr-1Mn-1.3Al-0.3Ti -Balance Ni ) was used as substrate material for the present study and the sample specimens were cut with dimensions of 20x15x3mm. Polishing of specimens was done using SiC emery papers of 100, 220, 400, 600 grit size. All the parameters were kept constant throughout the sample preparation process. After polishing the scanning electron images were analyzed. The hot corrosion study of specimens was carried out in waste incinerator plant, at Amritsar, Punjab, India. The plant operates as per the guidelines of Fifth Amendment in 2008 of Environment Protection Rules of 1986 by Ministry of Environment and Forests, Govt. of India, New Delhi. The gasses going to the atmosphere from the incinerator should be less than or equal to the parameter-specific emission standards. The samples were hanged in the secondary chamber of plant using steel wire through a hole at one of the edges of samples. The temperature in the plant varies due to heterogeneous nature of fuel and the average temperature at the position of hanged samples was 900°C. The study was conducted for 10 cycles with each cycle consisting of 100h of exposure followed by 1 h of cooling at ambient conditions. The weight of samples was measured after each cycle of study. The samples were visually examined at the end of each cycle for any change in the colour, luster, adherence of scale to the substrate and spalling tendency. After 10 cycles of studies, the corrosion products

and their distribution on the surfaces were studied with XRD and SEM/EDX analysis. For cross-sectional analysis the samples were sectioned and mounted in epoxy along cross-section. The mounted specimens were prepared by polishing, using SiC emery papers of 220, 400, 600 grit and subsequently 1/0, 2/0, 3/0, and 4/0 grades. Fine polishing was carried out using 0.3  $\mu\text{m}$  diamond paste. The prepared specimens were then analyzed by SEM/EDX techniques.

### 3. Results and Discussion

The weight change per unit area ( $\text{mg}/\text{cm}^2$ ) for the hot corroded coated superalloy for 1000 h exposure to the waste based incinerator environment follows parabolic law of rate and the parabolic rate constants  $k_p$  ( $\text{g}^2\text{cm}^{-4}\text{s}^{-1}$ ) found to be: 22.27. The average scale thickness for found to be: 217  $\mu\text{m}$  and the superalloy showed no indication of internal corrosion attack.

The diffraction patterns for the corroded coated specimen shows the presence of  $\text{Cr}_2\text{O}_3$  as major phase along with presence of  $\text{NiO}$ ,  $\text{Fe}_2\text{O}_3$  and  $\text{Al}_2\text{O}_3$ . The SEM/EDX analysis shows that the oxide scale formed on the surface of the specimens is interacting with the condensed phases of the ash. The scale is uniform and adherent after 1000 h exposure in waste incinerator environment. There is no indication of cracks and EDX analysis indicates that the white phase has composition similar to ash from the surrounding environment. The compact and adherent surface scale has small concentration of Fe and Ni, however, scale is rich in Cr, and oxygen. The presence of Fe in the surface scale can be attributes to the diffusion from the substrate or from deposited ash. There is minor diffusion of the elements from the deposits along the cross section of the scale of specimens. BSEI across the cross-section shows that there is formation of oxide scale layer at top surface, which is directly exposed to the waste incinerator environment. The EDX analysis across section shows mainly the presence Cr and oxygen elements with small concentration of Ni at the topmost scale layer of the specimen. There is diffusion of Mn and Ti in the coating from the superalloy substrate.

Despite of the presence of high concentration of Ni compared to Cr there is formation of oxide of chromium during exposure of the coated specimen. Though there are various factors, which influence the scale development, but the preferential formation of oxide of chromium as compared to Ni might be due to higher affinity of Cr for oxygen than Ni, and Cr forms more stable oxide and NiO is less stoichiometric oxide than  $\text{Cr}_2\text{O}_3$ .

The specimen proves to be effective in imparting the necessary protection to all the Ni-based superalloys, as the weight gain data of specimen follows parabolic rate law. There is no sign of oxidation of substrate superalloy. The SEM micrographs also show the formation of continuous, compact and adherent surface scale though with the presence of embedded ash particles after 1000 h exposure to waste incinerator environment. Therefore, it is conclude that the superalloy is able to provide effective and necessary protection to superalloy in the real service environment of waste incinerator.

### 4. Conclusions

1. The superalloy is suitable for application in corrosive environment.
2. The protective scale layer of  $\text{Cr}_2\text{O}_3$  formed on the exposed specimen in the waste incinerator environment.
3. The tested sample in this study is able to increase the life of boiler tubes in incinerator and other similar high temperature and corrosive environments.
4. The improved efficiency of the incinerator and waste to energy plant especially agriculture based plant will be beneficial for the agriculture dependent farmers and also the rural economy.



### References

- [1] Qu et al. 2020. High Temperature Corrosion Protection of Heating Surface Metals of Waste Incineration Power Generation Boilers: A Review”, *Journal of Physics: Conference Series* 1649, 012031.
- [2] Sidhu, T.S., Agarwal, R.D. 2005. Hot corrosion of some superalloys and role of high-velocity oxy-fuel spray coatings-a review. *Surface & Coatings Technology*, Vol. 198, pp. 441-446.
- [3] Singh, H., Sidhu, T.S. 2013. High temperature corrosion behavior of Ni-based superalloy Superni-75 in the real service environment of medical waste incinerator. *Oxidation of metals*, Vol. 80, No. 5-6, pp. 651-668.
- [4] Singh, H., Sidhu, T.S., Kalsi, S.B.S. 2013. Development of cold spray from innovation to emerging future coating technology. *Journal of the Brazilian Society of Mechanical Sciences and Engineering*, Vol. 35, pp. 231-245.
- [5] Singh, H., Sidhu, T.S., Kalsi, S.B.S. 2012. Cold spray technology: Future of coating deposition processes. *Frattura ed Integrità Strutturale/Fracture and Structural Integrity*, Vol. 6, No. 22, pp. 69-84.
- [6] Sidhu, T. S., Prakash, S. 2006. Hot corrosion and performance of nickel-based Coatings. *Current Science*, Vol. 90, No. 1, pp. 41-47.



### A ROBUST CONTROL FOR WIND ENERGY CONVERSION SYSTEM BASED ON FIVE PHASES PERMANENT MAGNET SYNCHRONOUS GENERATOR

**Douara Ben ouadeh<sup>1</sup>, Kouzou Abdellah<sup>2</sup>, Chouiha Youcef<sup>3</sup>, Karboua Djaloul<sup>4</sup>, Mebkhouta Toufik<sup>5</sup>**

<sup>1, 2, 3, 4</sup> Zain Achour University of Djelfa, Djelfa, Algeria

<sup>5</sup> Mohamed Khider University of Biskra, Biskra, Algeria

#### ABSTRACT

This paper presents an advanced technic control called sliding mode control applied on a wind energy conversion system based on five phases permanent magnet synchronous generator, where this control applied to enhance the performance of the system, and produce a better energy quality, sliding mode control is applied on this system due to external disturbance and uncertainty for achieving robust and precise performance, This technique creates a 'sliding surface' within the control system, where the system's behavior is directed towards sliding along this surface, leading to rapid convergence and stability. By continuously adjusting control inputs based on the system's current state and the sliding surface, sliding mode control effectively counters external disturbances and parameter variations. Its inherent ability to maintain desired performance in the face of uncertainty makes it a valuable control against wind speed changes, furthermore, the five phases PMSG is smoother to control and has more power distribution.



### SOLAR PUMPING SYSTEM BASED ON AN INDUCTION MOTOR

**Chouiha Youcef<sup>1</sup>, Beladel Abdelkader<sup>2</sup>, Kouzou Abdellah<sup>3</sup>, Douara Ben ouadeh<sup>4</sup>, Karboua Djaloul<sup>5</sup>,  
Mebkhouta Toufik<sup>6</sup>**

<sup>1, 2, 3, 4</sup> Zain Achour University of Djelfa, Djelfa, Algeria

<sup>6</sup> Mohamed Khider University of Biskra, Biskra, Algeria

#### ABSTRACT

In many places in the world where connecting to the grid is not possible and not economical, In such as places there must be alternative sources for generating electricity, one this common solution are the solar panels, solar pumping system is an effective and efficient way to power water pumps using solar energy. These systems efficiently lift and carry water for a variety of uses, including irrigation, cattle watering, and even residential usage in distant or off-grid places, by utilizing solar panels to capture the irradiation of the sun's energy, and convert that to electric energy. Solar pumping systems have a number of benefits, such as less dependence on fossil fuels, cheaper operating costs, and no environmental impact. In areas with plenty of sunshine, these systems can be crucial for improving agricultural output and ensuring access to clean water. They also help conserve resources. Overall, solar pumping systems serve as a shining illustration of the beneficial synergy between renewable energy and real-world uses for a more sustainable future, this paper deals with an example of a solar water pump based on an induction motor.



## CONVENTIONAL AND ADVANCED EXERGY ANALYSIS OF A RANKINE CYCLE

**Bahadır Erman YÜCE**

Assist. Prof. Dr., Bitlis Eren University, Faculty of Engineering and Architecture, Department of Mechanical Engineering, Bitlis-Türkiye, (Responsible Author) ORCID: 0000-0002-2432-964X

### ABSTRACT

Today, energy production and efficient utilization stand as crucial global concerns widely acknowledged worldwide because of the intense consumption. The adept design of power systems and their constituents holds paramount importance in achieving maximal output while minimizing losses. Hence, applying thermodynamic analyses becomes imperative to attain peak efficiency in energy production while concurrently enhancing energy quality. This study undertakes a comprehensive investigation, encompassing both conventional and advanced exergy analyses within the organic Rankine cycle. The conventional exergy analysis traditionally assesses the cycle's capacity to generate work. This study delves into whether the exergy losses within individual components stem from component-specific issues or from interactions with other elements. Furthermore, the study calculates avoidable and unavoidable exergy losses within each component. These computations encompass internal and external exergy losses, along with those that can be mitigated (avoidable) and those inherent to the system (unavoidable). These analyses are conducted under different working fluid selections, affording a profound comprehension of energy conversion processes. Consequently, the primary objective of this research is to enhance the efficiency and efficacy of energy production through comprehensive exergy analyses within the organic Rankine cycle. Moreover, scrutinizing the origins of exergy losses within each component bestows crucial insights for enhancing energy systems.

**Keywords:** Organic Rankine cycle, advanced exergy analysis, second law analysis



**PRODUCTION OF GELATIN/ARABIC GUM WALLED THERMOCHROMIC AND THERMAL ENERGY STORING MICROCAPSULES CONTAINING FLUORAN DYE**

**Müyesser Selda TÖZÜM**

Dr., Uşak University, Faculty of Engineering, Department of Textile, Uşak-Türkiye  
(Responsible Author) ORCID: 0000-0003-2887-5637

**Sena DEMİRBAĞ GENÇ**

Dr., Uşak University, Faculty of Engineering, Department of Textile, Uşak-Türkiye  
ORCID: 0000-0003-1634-6391

**Sennur ALAY AKSOY**

Prof. Dr., Süleyman Demirel University, Faculty of Engineering, Department of Textile, Isparta-Türkiye  
ORCID: 0000-0002-5878-6726

**ABSTRACT**

In this study, the production of bifunctional thermochromic and energy storing microcapsules with gelatin/arabic gum wall by complex coacervation method was carried out. The study aimed to produce thermochromic microcapsules with natural and biocompatible wall structure, temperature sensitive color-colorless reversible color transformation and storing/emitting latent heat energy during this transformation. For this aim, ternary thermochromic system (TS) that consisted of fluorane dye (2'-(Dibenzylamino)-6'-(diethylamino)fluorane) as color former (leuco dye), phenolphthalein as color developer and 1-tetradecanol as solvent was prepared as the core material and encapsulated. The solvent component, which was a phase change material (PCM), had also latent heat storage and release property. Microencapsulation of TS into gelatin/arabic gum wall was proven by Fourier transform infrared (FTIR) spectroscopy. The spherical shape and smooth surface of the produced microcapsules were determined by scanning electron microscopy (SEM) images. The average particle size (d<sub>50</sub>) of the microcapsules was determined as 17.34 micronmeters. Differential scanning calorimetry (DSC) analysis was performed to determine their thermal properties. According to DSC results, microcapsules exhibited latent heat energy storage capacity of 140.6 J/g at 34.5 °C and could be used as thermal energy storage materials for various applications such as textile, building, thermal sensor etc. The melting temperature of solvent determined color change temperature of TS as 34.5 °C. According to TGA analysis, the thermal decomposition temperature of the microcapsules was determined as 150 °C and microencapsulation reduced the mass loss value of the thermochromic system during decomposition. Temperature-dependent reversible color change of the microcapsules was investigated using photograph images taken different temperatures. The photographs images proved that microcapsules showed reversible color change from green to colorless with temperature variation.

**Keywords:** Fluoran dye, gelatin, arabic gum, microcapsules, thermochromic, energy storage

**Introduction**

In recent years, rapidly advancing science and technology has focused on the development of smart materials that can sense and respond to environmental stimuli. Smart materials are materials that can react on their own to changes in their environment. This response can take the form of a change in volume, color or viscosity with warning temperature variation, voltage etc. Thermochromic materials are materials that change color reversibly with temperature change. They are encountered in many areas of our daily lives such as ink, crayons, textile dyestuffs, color-changing cups and plates, toothbrushes, jewelry, batteries, color-changing t-shirts, camouflage clothing, architectural structures (Bamfield, 2010). In the textile field, leuco dye based and liquid crystal type thermochromic materials are preferred (Chowdhury et al. 2013). Leuco dye-based thermochromic materials consist of a leuco dye as a color former, a proton donor as a color developer and a hydrophobic and non-volatile solvent (Malherbe et al. 2010; Kulcar et al. 2010; Raditoiu et al. 2016). The solvent component

of the system is a phase change material and its melting temperature determines the color change temperature of the system. While the system is colored below the melting temperature of the solvent, it loses its color above the melting temperature of the solvent (Chowdhury et al. 2014). These system was used in textiles after encapsulation (Chowdhury et al. 2013). Encapsulation prevents both the flowing of the phase change material during the phase change and the change in the ratio of the components of the system.

In literature, while there are many studies on leuco dye based thermochromic systems microencapsulated with various synthetic polymers (Kim et al. 2018; Gao et al. 2012, Zhang et al. 2020; Tözüm et al. 2018; Tözüm et al. 2020; Tözüm et al. 2021; Özkayalar et al. 2020), there are very few studies on microencapsulation of thermochromic systems by complex coacervation method. These studies generally focused on analysis parameters affecting the morphology, particle size and distribution of microcapsules. Complex coacervation is a simple, versatile and highly efficient method that allows microencapsulation using natural polymers. It is a method that allows the encapsulation of different active ingredients into a natural and biocompatible polymer structure for many fields, from food to textile. In this study, we carried out the production of bifunctional thermochromic and energy-storing microcapsules with natural polymer (gelatin/arabic gum) wall by complex coacervation method. The morphology, temperature sensitive reversible color change behavior, chemical structure and thermal properties of the produced microcapsules were investigated.

### Materials and Methods

A 2'-(Dibenzylamino)-6'-(diethylamino) fluoran as color former, phenolphthalein (Sigma Aldrich) as color developer and 1-tetradecanol (>97%, Alfa Aesar) as solvent, were used to form ternary thermochromic system. Gelatin (Sigma Aldrich, Type A) as polycation polymer and arabic gum (Sigma Aldrich) as polyanion polymers were employed as wall materials of microcapsules. Cetyl trimethyl ammonium bromide (CTAB, Sigma Aldrich) was used as cationic surfactant in the production of microcapsules. To stabilize the microcapsules, glutaraldehyde (2.5%, Sigma Aldrich) was used as a crosslinker. Acetic acid (10%) and sodium hydroxide (5%) solutions were used for pH adjustments during the microcapsule production stages.

In the preparation of the ternary TS, the our previously reported procedure was used. The weights ratio of fluoran dye, phenolphatelein, and 1-tetradecanol were 0.055/0.09/6.42 (Özkayalar & Alay Aksoy, 2020). The microencapsulation of the prepared ternary TS was carried out by complex coaservation method. The core/shell ratio of microcapsules was 1:0.5. In the microcapsule production process, the prepared ternary TS was dispersed in 50 ml of a 1.25 % (w/v) gelatin solution in the presence of CTAB (0.10 g) surfactant. The 50 ml of a 1.25 % (w/v) arabic gum solution dripped into the created emulsion and the pH was adjusted to pH 4 where the two polymers had oppositely charged in order to form complex between their molecules. After one and half hour, sodium hydroxide was dripped to adjust the pH to 9 and complex formation was stopped. Afterward, the temperature of emulsion system was decreased to 4 °C and 0.8 g of glutaraldehyde was added to stabilize the microcapsules. Figure 1 shows the schematic view of the production of energy storing microcapsules with gelatin/arabic gum wall by the complex coacervation method.

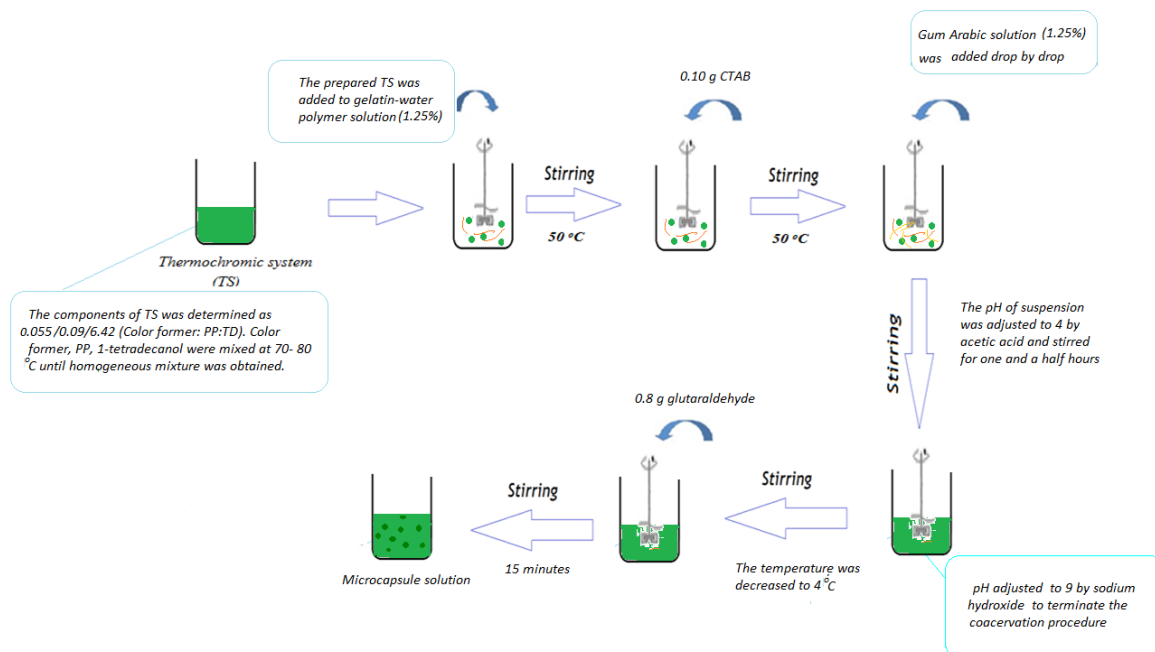

**Figure 1.** Schematic view of the production of thermochromic and energy storing microcapsules with gelatin/arabic gum wall

The morphological properties of microcapsules were investigated using ZEISS GEMINI 500 model SEM instrument. The particle size analyzer (Horiba LA-350) was used to measure the particle size of the microcapsules. The microcapsules were characterized chemically using ATR-FTIR (Perkin Elmer) analysis. The temperature-sensitive reversible color changes of the produced microcapsules were examined with images taken at 50 °C and 25 °C. Besides, the phase transition characteristics of microcapsules was characterized using Perkin Elmer DSC instrument. Thermal stability of microcapsules was investigated via thermogravimetric analysis (TG) using a Perkin Elmer Diamond instrument. Analyses were performed in a nitrogen atmosphere at a scanning rate of 10 °C/min in the temperature range of 0 °C to 500 °C.

## Findings and Discussion

### Morphologies of microcapsules

Morphology of the microcapsules was examined by SEM analysis. According to SEM images shown in Figure 2, the capsules had an ideal spherical morphology with smooth surface and almost uniform particle sizes. Additionally, the size scales given on the SEM images that the particle sizes of the microcapsules were almost 200 nm.

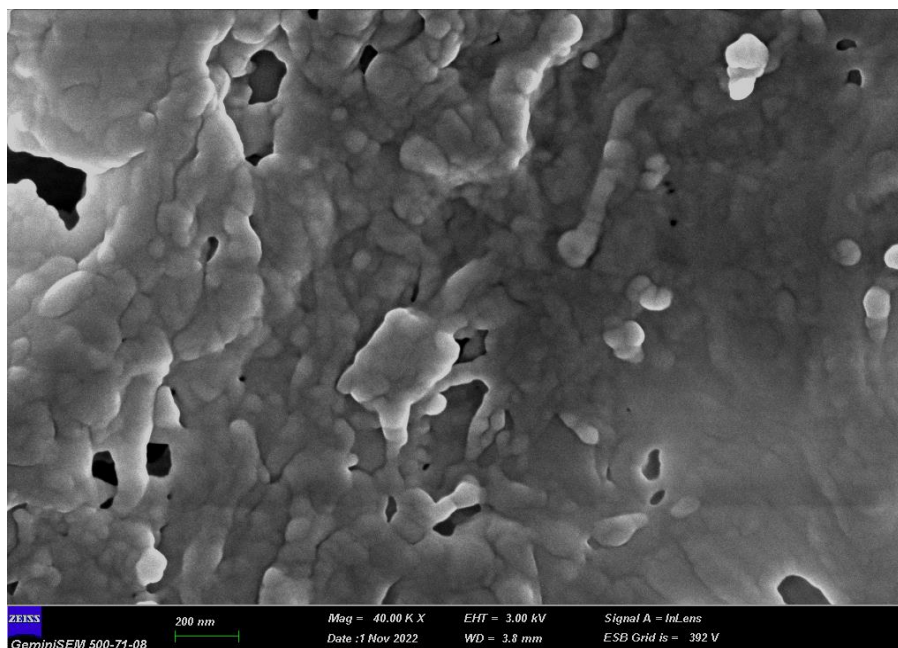

**Figure 2.** SEM images of microcapsules

### Particle sizes and size distribution of microcapsules

The particle size distribution histogram of the microcapsules was presented in Figure 3. According to the Figure 3, particle size distribution of the microcapsules exhibited narrow and unimodal. The mean particle size of microcapsules was 17.34  $\mu\text{m}$  and their particle size range varied between 5.55-58.76  $\mu\text{m}$ . The difference between the SEM images of the microcapsules and the dimensions measured by the particle size analyzer device is due to the measurement principle of the particle size measuring device and the tendency of the particles to cluster. As seen in the SEM image, the produced capsules exhibited a tendency to cluster, making it difficult to examine their morphology. This result is due to both the small particle size of the capsules and the intermolecular forces of attraction between the functional groups of the polymers in the capsule wall structure. Since clustered capsule groups are detected as a single particle in the particle size measuring device, microcapsule sizes are measured as larger.

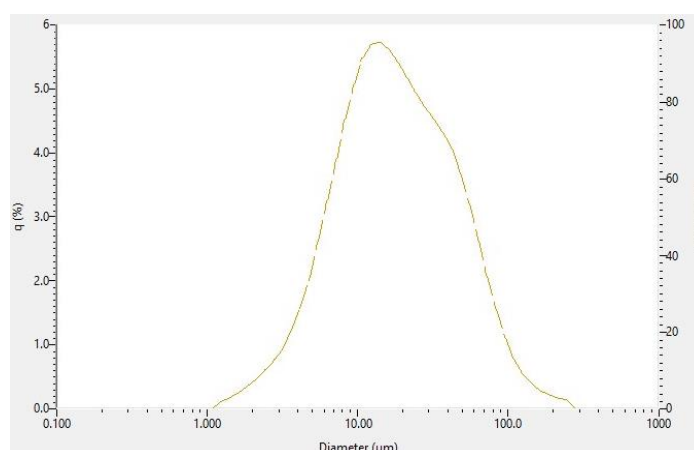
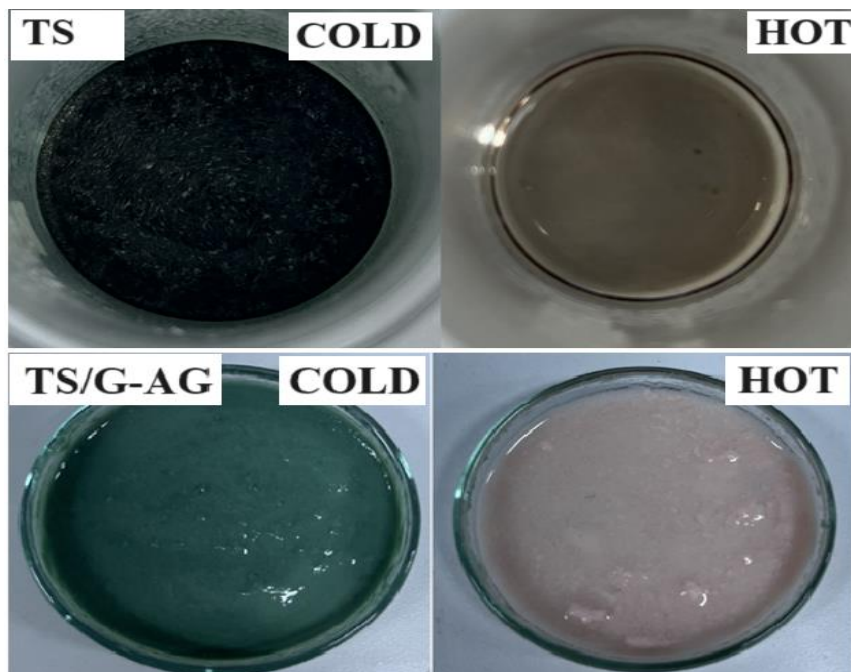

**Figure 3.** PSD of microcapsules



### Color Photo Analysis

Photographs of TS and microcapsules taken at cold (around room temperature) and hot (50 °C) medium were given in Figure 4. The system was in solid state and dark green color at cold medium. At about 50 °C, the TS was completely colorless and in liquid state. The microcapsules were also green color at cold medium. At above the activation temperature, they lost their color completely.



**Figure 4.** Photographs of microcapsules at hot medium and cold medium

### FT-IR spectroscopic analysis

FTIR curves for the materials used in the preparation of microcapsules, TS, gelatin, arabic gum and microcapsules were given in Figure 5. The large and broad peak observed at 3223-3282  $\text{cm}^{-1}$  in the spectra of microcapsules was a combination of the  $-\text{OH}$  stretching peaks of arabic gum, the  $\text{N-H}$  stretching peaks of gelatin as well as the  $-\text{OH}$  stretching peaks of the 1-tetradecanol and phenolphthalein. The peaks at 2849  $\text{cm}^{-1}$ , 2917  $\text{cm}^{-1}$  and 2957  $\text{cm}^{-1}$  were the peaks of characteristic to  $\text{C-H}$  stretching peaks of 1-tetradecanol, which was the solvent of TS. The strong and sharp peaks appearing at 1472  $\text{cm}^{-1}$  and 1463  $\text{cm}^{-1}$  in the spectrum of microcapsules were the  $\text{C-H}$  bending peak of 1-tetradecanol in TS. The peak at 1375  $\text{cm}^{-1}$  in the spectrum of microcapsules belongs to the symmetric stretching of carboxylate groups resulting from the ring opening of the dye in the TS.

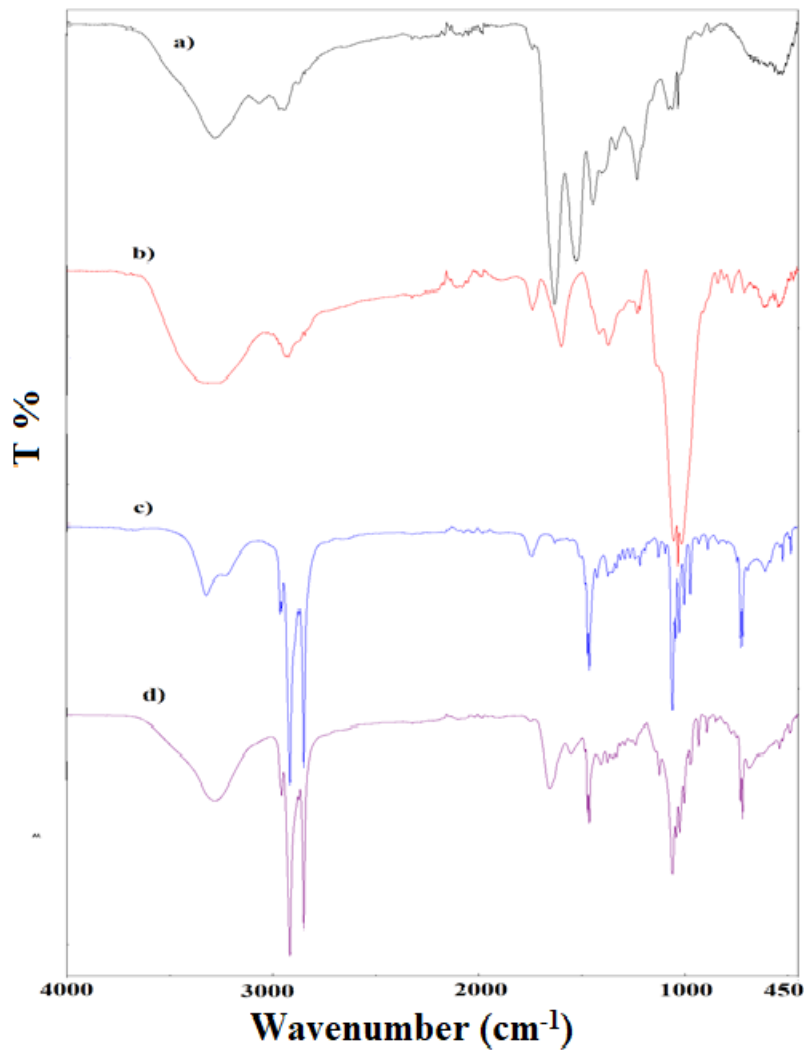

**Figure 5.** FTIR spectra of gelatin (a), arabic gum (b), TS (c), microcapsules (d)

### DSC Analysis

DSC curve including phase change temperatures and melting and crystallization enthalpies of microcapsules was given in Figure 6. According to Figure 6, microcapsules absorbed 140.6 J/g of latent heat energy at 34.5 °C. Their crystallization and solid-solid transition enthalpies were measured as -56.1 J/g at 35.4 °C and -23.9 J/g at 28.9 °C, respectively.

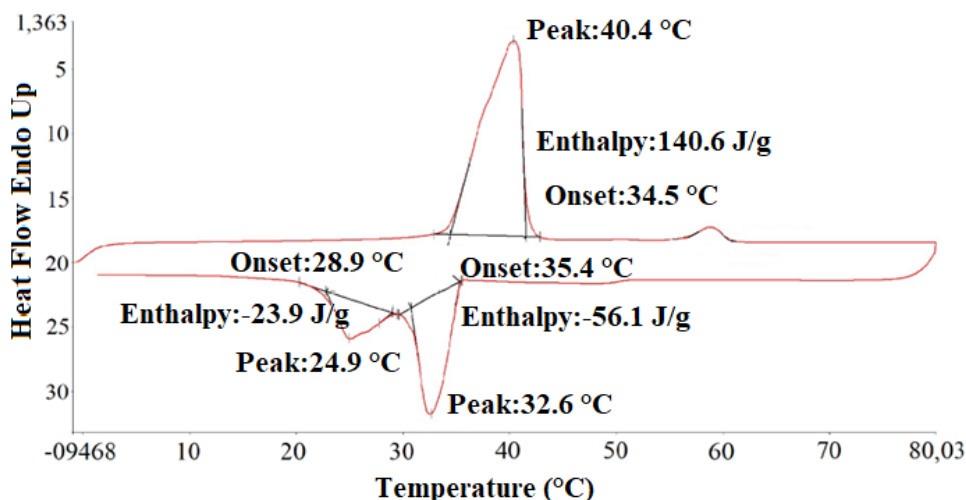

Figure 6. DSC thermogram of microcapsules

**TG Analysis**

To determine thermal endurance of microcapsules, TG analysis was performed. From the TG curve given in Figure 7, it was seen that microcapsules degraded in two steps. Microcapsules started to lose weight at around 150 °C and the first step weight loss ratio of microcapsules was 52.34%. This weight loss was due to the evaporation of the thermochromic system. The second weight loss of microcapsules was 23.73% in the range of 230 °C to 400 °C. This second degradation was assigned to the degradation of the polymeric shell. TGA results showed that the microcapsules had adequately thermal stability for textile applications.

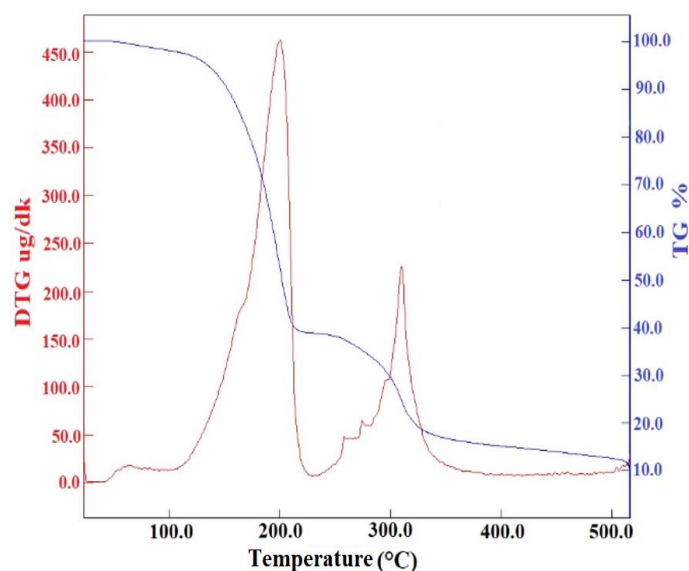

Figure 7. TG curve of microcapsules

**Conclusion and Recommendations**

In this study, which aimed to produce bifunctional microcapsules with thermochromic and thermal energy storage properties, microcapsule production by complex coacervation method was realized successfully. In the study, gelatin and arabic gum polymers with natural and biocompatible were used as shell materials. The core

material was leuco dye-based ternary thermochromic system which consisted of fluorane dye as leuco dye, phenolphthalein as color developer and 1-tetradecanol as solvent. According to SEM images, it was observed that microcapsules with spherical and smooth surfaces were produced. Photographs of microcapsules taken at cold and hot medium showed that microcapsules had reversible color change performances from green to colorless. From DSC and TG analysis results, it was determined that the latent heat energy storage capacity of microcapsules was 140.6 J/g at around 34.5 °C and they had good thermal stability. Consequently, the produced microcapsules were suitable for using as energy storage materials in textile and non-textile materials.

### Acknowledgements

The Authors would like to express their sincere gratitude to TÜBİTAK (Project No. 221M773).

### References

- Bamfield P and Hutchings MG. Chromic phenomena: Technological applications of colour chemistry. 2th ed. Cambridge: United Kingdom, 2010, 548.
- Malherbe I, Sanderson RD, & Smit E. (2010). Reversibly thermochromic micro-fibres by coaxial electrospinning, *Polymer*, 51(22): 5037-5043.
- Kulcar R, Friskovec M, Hauptman N, Vesel A, & Klanjsek Gunde M. (2010). Colorimetric properties of reversible thermochromic printing inks, *Dyes Pigments*, 86(3):271-277.
- Raditoiu A, Raditoiu V, Nicolae CA, Raduly MF, Amariutei V, & Wagner LE. (2016). Optical and structural dynamical behavior of crystal violet lactone-phenolphthalein binary thermochromic systems, *Dyes Pigments*,;134:69-76.
- Chowdhury MA, Joshi M, & Butola BS. (2014). Photochromic and thermochromic colorants in textile applications, *Journal of Engineered Fibers and Fabrics*, 9(1):107-123.
- Chowdhury MA, Butola BS, & Joshi M. (2013). Application of thermochromic colorants on textiles: temperature dependence of colorimetric properties, *Coloration Technology*, 129(3):232-237.
- Kim, I.J., Ramalingam, M., & Son, Y.A. (2018). "Investigation of reversible self-thermochromism in microencapsulated fluoran-based materials", *Dyes and Pigments*, 151, 64-74.
- Gao, J., Guan, P., Hu, X. L., & Cao, M. (2012). Structure and Properties of Cobaltous Chloride/Polyvinyl Alcohol-Glutaraldehyde (CC/PVA-GA) Reversible Thermochromic Microcapsule, In *Key Engineering Materials*, 501, 231-236, Trans Tech Publications Ltd.
- Zhang, Y., Liu, H., Niu, J., Wang, X., & Wu, D. (2020). "Development of reversible and durable thermochromic phase-change microcapsules for real-time indication of thermal energy storage and management", *Applied Energy*, 264, 114729.
- Tözüm, M.S., Alay Aksoy, S., & Alkan, C., (2018). Microencapsulation of Three-Component Thermochromic System for Reversible Color Change and Thermal Energy Storage, *Fibers and Polymers*, 19(3), 660-669. DOI 10.1007/s12221-018-7801-3
- Tözüm, M.S., Alkan, C., & Alay-Aksoy, S., (2020). Preparation of Poly(methyl methacrylate-co-ethylene glycol dimethacrylate-co-glycidyl methacrylate) Walled Thermochromic Microcapsules and Their Application to Cotton Fabrics, *Journal of Applied Polymer Science*, 137, 24, 1-13.
- Tözüm, M.S., Alay Aksoy, S., & Alkan, C., (2021). Manufacturing surface active shell and bisphenol A free thermochromic acrylic microcapsules for textile applications, *Fibers and Polymers*, *International Journal of Energy Research*, 45 (5), 7018-7037, DOI: 10.1002/er.6287.
- Özkayalar, S., Adıgüzel, E., Aksoy, S. A., & Alkan, C. (2020). Reversible color-changing and thermal-energy storing nanocapsules of three-component thermochromic dyes. *Materials Chemistry and Physics*, 252, 123162.



**NANOENCAPSULATION OF FLUORAN DYE AND N-DODECANOL BASED SYSTEMS WITH PMMA-CO-GMA WALL FOR THERMOCHROMIC AND THERMAL ENERGY STORAGE FUNCTIONS**

**Sennur ALAY AKSOY**

Prof. Dr., Süleyman Demirel University, Faculty of Engineering, Department of Textile Engineering, Isparta-Türkiye  
(Responsible Author) ORCID: 0000-0002-5878-6726

**Simge ÖZKAYALAR**

PhD student, Dokuz Eylül University, Faculty of Engineering, Department of Textile Engineering, İzmir-Türkiye  
ORCID: 0000-0002-5390-8317

**Cemil ALKAN**

Prof. Dr., Tokat Gaziosmanpaşa University, Faculty of Faculty of Science and Literature, Department of Chemistry, Tokat-Türkiye  
ORCID: 0000-0002-1509-4789

**ABSTRACT**

Thermochromic dyes change their color reversibly depending on change in temperature. Because of their temperature sensing property, thermochromic materials have attracted considerable interest in the production of smart textiles, thermal indicators, building coatings, security printing, food packaging, medical thermography etc. An important group of thermochromic dyes are three-component thermochromic systems (TSs). The system consists of three components: color-forming dye, color developer and solvent. The solvent component of the system determines the activation temperature at which the system changes color. This component is also a phase change agent and has the function of thermal energy storage. In this study, poly(methyl methacrylate-co-glycidyl methacrylate) (PMMA-co-GMA) walled nanoencapsulated TSs having latent heat storage property were prepared using emulsion polymerization method. TSs consist of fluorane dye as color former, phenolphthalein as color developer and n-dodecanol as solvent were prepared. In the study, two different TSs containing green 2'-(Dibenzylamino)-6'-(diethylamino) fluorane or black 2-Anilino-6-dibutylamino-3-methylfluorane dyes were prepared and encapsulated. While the TSs and capsules shown colorless at high temperatures, i.e. above the melting temperature of the solvent, they became green or black at temperatures below the solidification temperature of the solvent. The formation and spherical morphology of the capsules were determined by FT-IR spectroscopy and SEM images. The green capsules stored energy of 103 J/g during heating at 7.9 °C (peak at 19.6 °C), while they emitted a total of 67.16 J/g of heat energy during the liquid-solid (at 17 °C) and solid-solid (at 9 °C) phase transitions. The black capsules stored totally 97.51 J/g of heat at 19 °C during heating and emitted 102.2 J/g of heat at 17.9 °C during cooling. It was noted that the degradation initiation temperatures of the nanocapsules were above 170 °C and the encapsulated TSs exhibited sufficient thermal resistance for thermal energy storage application fields.

**Keywords:** Thermochromic, phase change, fluorane dye, thermal energy storage.

**Introduction**

The storage of thermal energy in the form of sensible and latent heat has become an important aspect of energy management. Latent heat storage by phase change materials (PCMs) is one of the most efficient ways of storing thermal energy. PCMs can absorb, store and release large amounts of latent thermal energy during their process of physical state change without changing their temperature (Jeon et al., 2013; Wang et al., 2023). Nowadays, PCMs which are accepted as the clean green materials are attracting increasing attention to enhance the energy utilization efficiency and thermal regulation. Recently, the topic of encapsulation of phase change materials with thermochromic function has been considered as a promising research topic attracting considerable commercial interest (Zhang et al., 2020; Li et al., 2023). In particular, leuco dye-based three-

component thermochromic systems (TSs) have been selected as the core materials for the fabrication of temperature-sensitive thermochromic microcapsules/nanocapsules.

Thermochromic materials are temperature sensitive compounds that change their color reversibly by a change of temperature. The leuco dye based three-component systems include a color former (leuco dye or electron acceptor), a color developer and a solvent. Color former is a pH-sensitive leuco dye compound that receives color by taking a proton from color developer. The color developer is a weak acid that acts as proton donors to generate the colored state of the leuco dye components. The solvent, which is a phase change material (PCM), has also latent heat storage and release property. Besides, the function of the solvent in the system is to create a suitable medium for interactions between the leuco dye and the color developer. The colour formation mechanism of leuco dyes is based on the interaction between the dye and the developer and this interaction is controlled by the solvent component of the system. If the solvent component of the TS is in solid form, the system will show colour as the interaction between the dye and the developer takes place. Conversely, if the system is heated above the melting temperature of the solvent, the organic solvent melts and the interaction between the colour former and the colour developer ends. The melting point of the solvent is the deterministic value for activation of the system (Bašnec et al., 2018; Tözüm et al., 2021; Li et al., 2023).

In most applications, thermochromic systems are encapsulated in a protective and transparent shell prior to application. Encapsulation provides protection for the dye, which is very sensitive to external conditions. It maintains the TS as a solid particle when it is liquid. It provides a homogeneous mixture of the ternary system and prevents the change of composition ratios (Tözüm et al., 2021; Li et al., 2023). In this study, poly(methyl methacrylate-co-glycidyl methacrylate) walled nanoencapsulated TSs with latent heat storage property were prepared by emulsion polymerization method. The aim of this study was to prepare reactive walled nanocapsules with high thermal energy storage capacity and markedly reversible color change function. The nanocapsules are expected to exhibit thermochromic and thermal energy storage properties due to the three-component thermochromic system they contain, and to exhibit adhesion to organic materials such as fibres with intermolecular attractive forces due to their wall structure.

## Materials and Methods

In the preparation of TSs, 2'-(Dibenzylamino)-6'-(diethylamino) fluorane and 2-Anilino-6-dibutylamino-3-methylfluorane dyes supplied from TCI Chemicals Company were used as color former. PP (Carlo Erba) was used as the color developer and n-dodecanol (Acros Organics, %98) was used as a solvent. To improve the resistance of TSs against light, 2,4-dihydroxybenzophenone (UVA) (Alfa Aesar, 99%) was employed as UV absorber material. In the synthesis of nanocapsules, methyl methacrylate (MMA, Sigma Aldrich, %99) monomer and glycidyl methacrylate (EGDM, Sigma Aldrich, %98) co-monomer were used. Ethylene glycol dimethacrylate (EGDM, Sigma Aldrich, 98%) was served as cross-linker. 2,2'-Azobis(2-methylpropionamide) dihydrochloride (Aldrich, 97%) was initiator used to initiate free radical polymerization in nanocapsule synthesis process. Polyethylene glycol 1000 (PEG 1000) was employed as emulsifier.

In the preparation of thermochromic systems, the dye/developer/solvent ratio was kept constant as 0.55/0.09/6.42 in grams. Appropriate amounts of dye and phenolphthalein were added to the solvent heated to approximately 90 °C and stirred until dissolved. 2,4-Dihydroxybenzophenone (UVA) UV absorber (6 times than the amount of dyestuff) was added to the thermochromic systems to improve the generally known low UV resistance properties of thermochromic systems.

The production of the PMMA-co-GMA walled nanocapsules containing TSs was carried out by oil-in-water emulsion polymerization method (Özkayalar et al. 2020). The wall/core ratio was chosen as 0.5:1. The monomer (MMA)/co-monomer (GMA) ratio was used as 9/1. A 6.5 g of ternary TS was added into 100 ml of deionized water at 50 °C and emulsified by adding 2 g of PEG1000 surfactant by stirring for half an hour at a mixing speed of almost 3000 rpm. Then, 3.25 g of monomer (e.g. MMA and GMA mixing), 1.35 g of EGDM cross-linker and 1 g of initiator were added to the emulsion and the temperature was increased to 80 °C to initiate polymerization reaction. Stirring speed was decreased to 1000-2000 rpm. The nanocapsules were produced by polymerization reaction about three hours, washed several times with hot water at 70 °C, filtered

and stored in the refrigerator. The information about the prepared TSs and nanocapsules was presented in Table 1.

**Table 1.** Contents of TSs and nanocapsules

Nanocapsule code	Core material	TS content			
		Dye	UV Absorber	Color developer	Solvent
PMMA-co-GMA/TS1	TS1	2'-(Dibenzylamino)-6'-(diethylamino) fluorane 0,055 g	0,33 g- UVA	Phenolphthalein 0,09 g	N-dodecanol 6,42 g
PMMA-co-GMA/TS2	TS2	2-Anilino-6-dibutylamino-3-methylfluorane 0,055 g			

The thermochromic behavior of TSs and nanocapsules were investigated with photograph images taken by using a digital camera at different temperatures. TSs were placed in beakers as the nanocapsules were placed on petri dishes. Firstly, photographs of TSs and nanocapsules at melting temperature of the TS were taken. Then, photographs of the same samples were taken when they cooled back to room temperature. To examine the morphology of the produced nanocapsules, scanning electron microscopy (SEM, LEO 440 Computer Controlled Digital) analysis was carried. Before analysis, conductivity of the samples was supplied by covering their surface with gold coating. FTIR spectroscopy analysis was performed to determine chemical structures of nanocapsules using Perkin Elmer Spektrum BX instrument. The formation of the shell structure of the nanocapsules and the presence of the core material in the capsule structure were investigated. Analyzes were carried out with KBr pellet technique at 4 cm<sup>-1</sup> resolution, in the 4000-400 cm<sup>-1</sup> middle infrared region with 2 cm<sup>-1</sup> intervals. TG analysis was carried out to examine the thermal stability of nanocapsules using a Perkin Elmer TGA7 instrument. Measurements were realized in the range of 0-500 °C, at a heating rate of 10 °C/d under air atmosphere. The phase transition points and heat storage/release capacities of the nanocapsules were determined by a differential scanning calorimetry (DSC, Perkin-Elmer Jade). The measurements were carried out at a heating rate of 1 °C/min, between the temperature of -5 °C and 65 °C under nitrogen gas.

### Findings and Discussion

At below and above the phase transition temperature of TSs, colored and colorless photos of TSs and nanocapsules were presented in Figure 1 and Figure 2, respectively. It was seen that the TSs were colored in cold state while they were colorless above the activation temperatures and returned to their original colors when they were cooled again. In the cold, TS1 turns dark green while TS2 turns black. According to the photos of TS nanocapsules, nanocapsules exhibited a markedly thermochromic color change. The color of the capsules changed significantly from green to colorless (capsule wall polymer color) or from black to colorless depending on the color of the TS they contained (Figure 2).

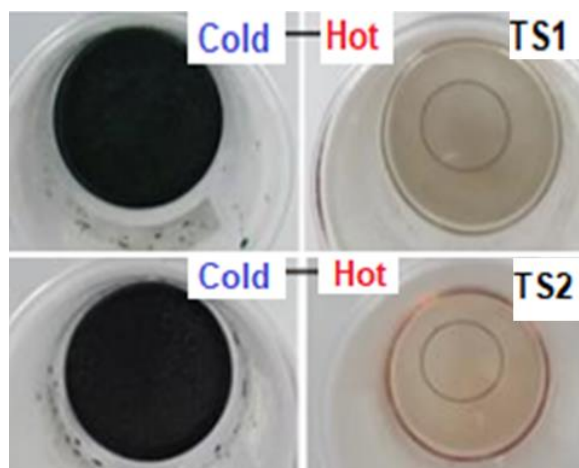

**Figure 1.** Reversible color change properties of the TSs depending on change in temperature

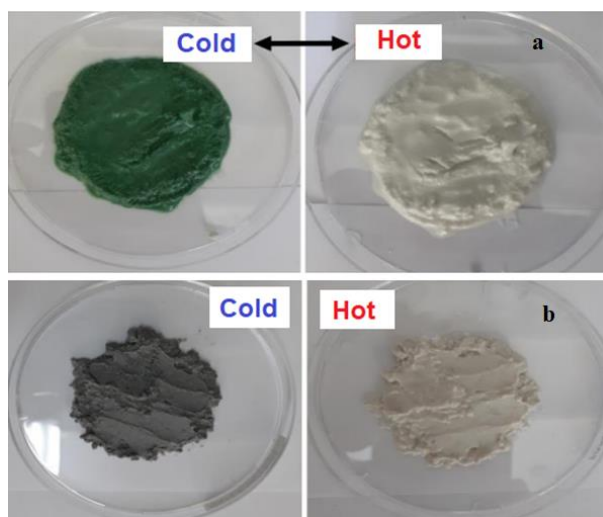

**Figure 2.** Reversible color change properties of the nanocapsules depending on temperature (a: PMMA-co-GMA/TS1 and b: PMMA-co-GMA/TS2)

Figure 3 showed the SEM images of PMMA-co-GMA/TS1 nanocapsules as sample images. SEM images showed the formation of capsules with nano-sized particles and their spherical morphology. In addition, the images showed that the particles were homogeneous in size. According to the size scales given on the images, their particle sizes were below 100 nm. It was also seen that the particles were agglomerated in clusters. This is thought to be related to the nano-sized particle size.



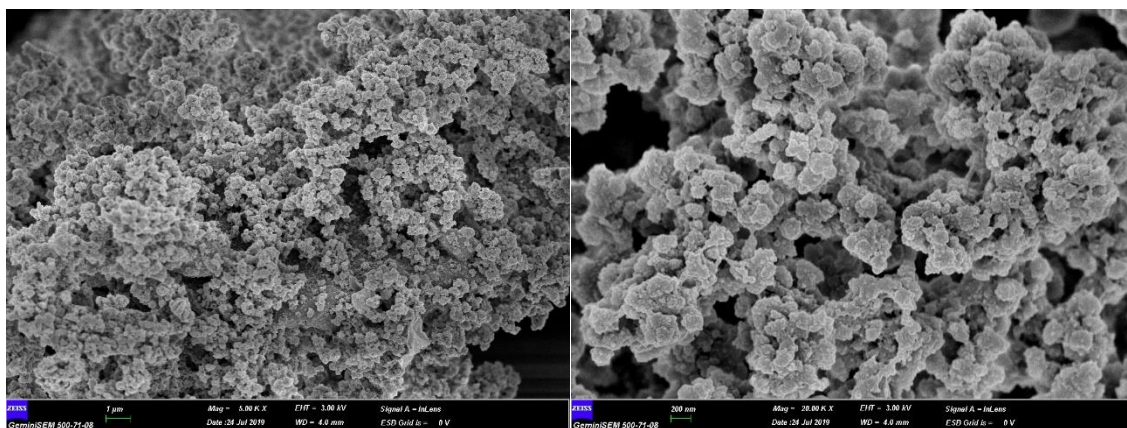

**Figure 3.** SEM images of the PMMA-co-GMA/TS2 nanocapsules

FT-IR spectroscopy analysis was used to study the chemical structure of the capsules. FT-IR spectra of the nanocapsules and the core material TSs were given in the Figure 4. In the Table 2, information about the characteristic peaks of the materials obtained from the spectra was given.

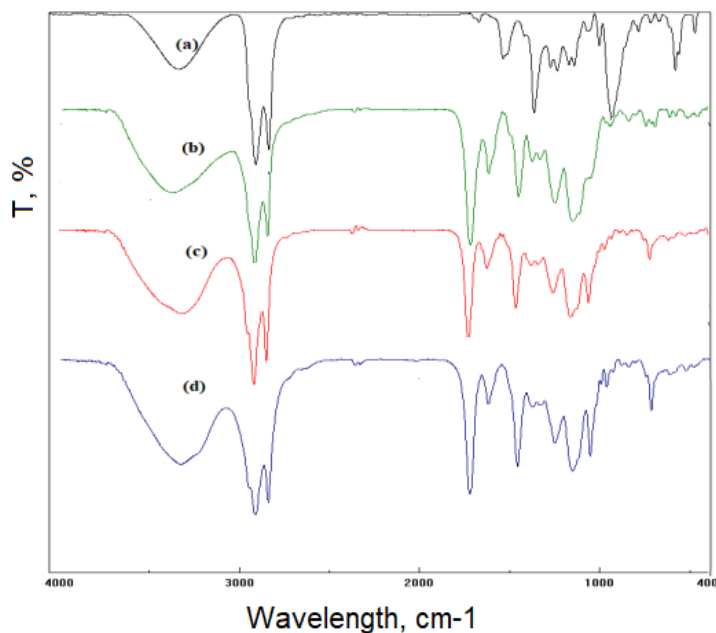

**Figure 4.** FT-IR spectra of TS1 (a), PMMA-co-GMA/TS1 nanocapsules (b), PMMA-co-GMA/TS2 nanocapsules (c), TS2 (d)

**Table 2.** Information about the characteristic FT-IR spectrum peaks of the materials

Material	FT-IR spectrum peak wavelengt (cm <sup>-1</sup> )	Peak source
PMMA-co-GMA/TS1 nanocapsules	2925 and 2854	the characteristic C-H stretching peaks of n-dodecanol
	1461	the C-H bending peak of n-dodecanol
	722	the C-H shaking peak of n-dodecanol
	3363	the overlapped -OH stretch band of n-dodecanol and phenolphthalein
	1728	carbonyl peak of phenolphthalein
	1626	the overlapping peak of the carboxylate of the dye and the carbonyl group of the MMA monomer
	1345	characteristic peak of UV absorber
PMMA-co-GMA/TS2 nanocapsules	2923 and 2856	the characteristic C-H stretching peaks of n-dodecanol
	1465	the C-H bending peak of n-dodecanol
	722	the C-H shaking peak of n-dodecanol
	3363	the overlapping of -OH stretch band of n-dodecanol and phenolphthalein
	1726	carbonyl peak of phenolphthalein
	1626	the overlapping peak of the carboxylate of the dye and the carbonyl group of the MMA monomer
	1345	Characteristic peak of UV absorber

In the FT-IR spectra of the nanocapsules:

- The characteristic C-H stretching and bending peaks of n-dodecanol are present
- the overlapping -OH stretching band of n-dodecanol and phenolphthalein is present
- The carbonyl peak of phenolphthalein is present.
- The overlapping peak of the carboxylate of the dye and the carbonyl group of the MMA monomer is available.
- The characteristic peak of the UV absorber is available
- On the other hand, the C=C stretching peak at 1639 cm<sup>-1</sup> of the MMA monomer and the C=C stretching peak at 1633 cm<sup>-1</sup> of the GMA monomer were not observed in the nanocapsule spectrum. This finding indicated that the nanocapsule with (PMMA-co-GMA) wall was synthesized as a result of the polymerization reaction between the monomers.

According to the DSC analysis results of TSs (Figure 5 and Table 3), the melting temperatures of the thermochromic systems were around 18.5 °C, while their solidification temperatures were 18.4 °C and 18.9 °C. Their heat storage capacities ranged from 179 j/g to 188 j/g, while their heat dissipation capacities were 172 and 186 j/g. DSC analysis results show that the heat storage capacities of the TSs are very high and they are candidates for an effective thermal energy storage material. In addition, their energy storage and releasing temperatures are suitable for human body temperature.

**Table 3.** DSC analysis results of TS1 and TS2

TS	Tm (°C)	Heat storage capacity (j/g)	Tc (°C)	Heat releasing capacity (j/g)
TS1	18.5	188.4	18.4	186.5
TS2	18.6	179.4	18.9	172.6

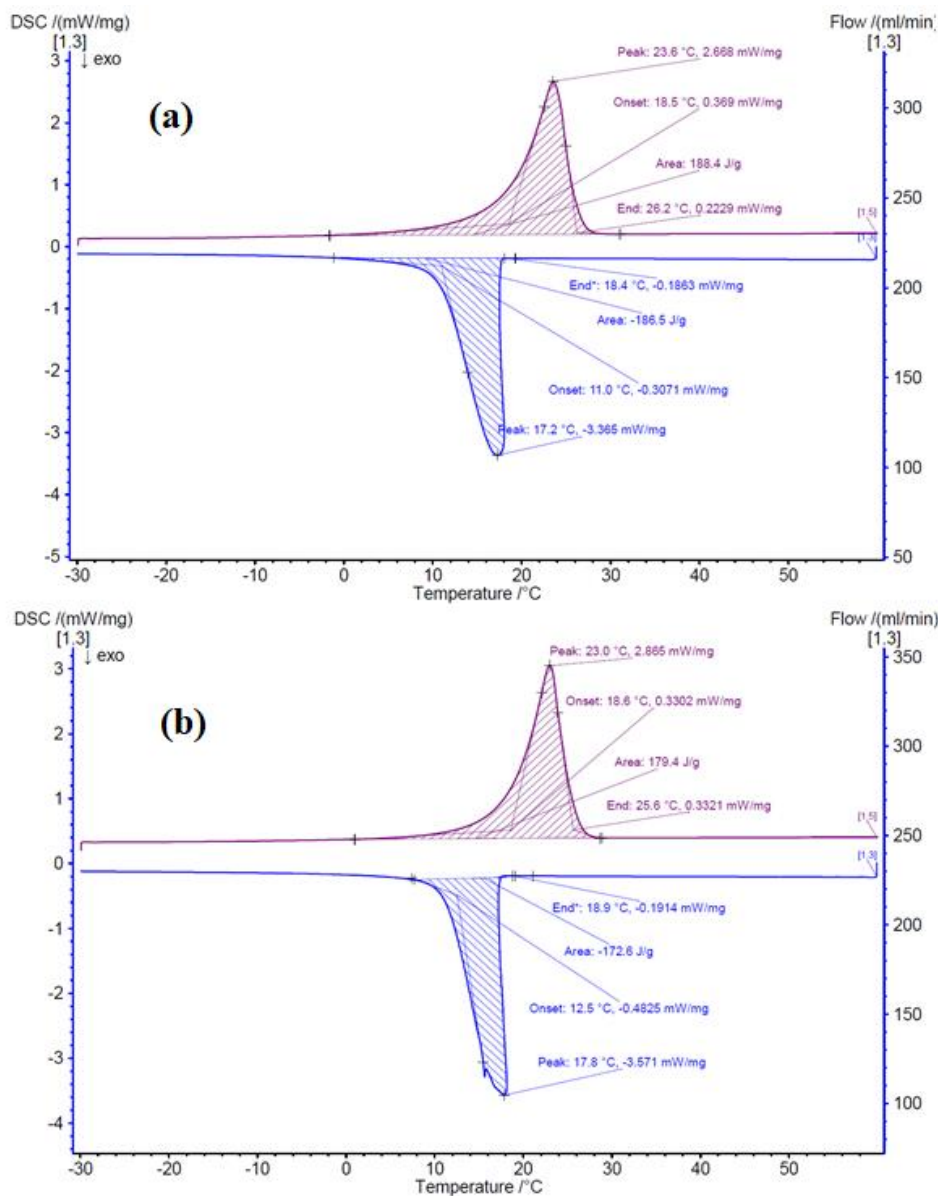
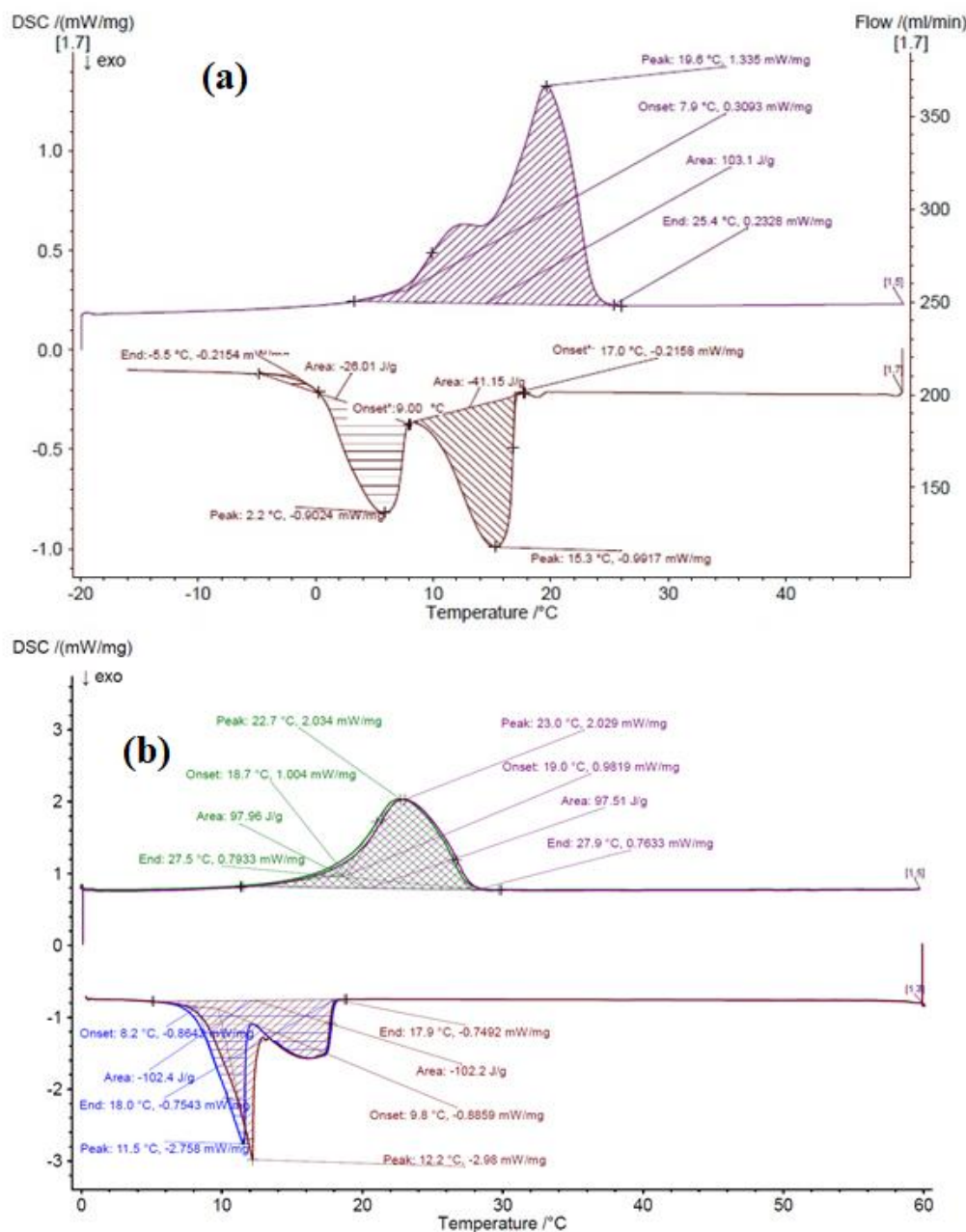

**Figure 5.** DSC curves of the TSs (a:TS1 and b: TS2)

According to the DSC analysis results of PMMA-co-GMA/TS1 and PMMA-co-GMA/TS2 nanocapsules (Figure 6 and Table 4), The energy storage capacity decreased significantly after encapsulation process. However, it can be said that the capsules have a high energy storage capacity with a melting enthalpy of about 100 j/g. As with the TSs, their energy storage temperatures are suitable for the human body temperature.

**Table 4.** DSC analysis results of the nanocapsules

Nanocapsules	Tm peak (°C)	Heat storage capacity (j/g)	Tc (°C)	Heat releasing capacity (j/g)
PMMA-co-GMA/TS1	7.9 (19.6 peak point)	103,1	17 °C liquid-solid 9 °C solid-solid	67.16
PMMA-co-GMA/TS2	19 °C (23.0 peak point)	97.51	17.9	102.2



**Figure 6.** DSC curves of the nanocapsules (a:PMMA-co-GMA/TS1 nanocapsules, b: PMMA-co-GMA/TS2 nanocapsules)

According to the TG analysis results, nanocapsules were subjected to a two-stage thermal degradation. The first degradation was due to the evaporation of the solvent component of the capsule core material and its leakage from the shell structure. The second stage degradation was caused by the degradation of the

nanocapsule wall structure. The degradation initiation temperatures of the nanocapsules were above 170 °C and the encapsulated TSs exhibited sufficient thermal resistance for thermal energy storage application fields.

**Table 5.** TG analysis results of the nanocapsules

Nanocapsules	The first step degradation			The second step degradation		
	Initiation	End	weight loss, %	Initiation	End	weight loss, %
PMMA-co-GMA/TS1	176.44	229.54	37.18	358.69	447.83	45.00
PMMA-co-GMA/TS2	179,94	229,85	46.20	352,98	448,14	46.41

### Conclusion and Recommendations

In the study, two different TS containing fluorane dye with two different colours were prepared and nanoencapsulated by emulsion polymerization method. The TS and capsules were colourless above the melting temperature of the solvent, while they became green or black at temperatures below the solidification temperature of the solvent. SEM analysis showed the formation of capsules with nano-sized particles and their spherical morphology. According to the SEM images, the particle sizes were less than 100 nm. The synthesis of the capsule polymer wall structure and the core material content were confirmed by FT-IR spectroscopy. According to the DSC analysis, TS had a very high thermal energy storage capacity (about 180 j/g). The energy storage/release temperatures were suitable for human body temperature. The capsules had high energy storage capacity with a melting enthalpy of about 100 j/g. TSs and nanocapsules had energy storage temperatures suitable for human body temperature. The degradation initiation temperatures of the nanocapsules were above 170°C. In conclusion, the TS nanocapsules exhibit sufficient thermal resistance and high thermal energy storage capacities for applications in thermal energy storage and the development of thermo-regulating textiles.

### Thanks and Information Note

The authors would like to express appreciation for the support to TUBITAK [Project Number 118M012].

### References

- Jeon, J., Lee, J. H., Seo, J., Jeong, S. G., & Kim, S. (2013). Application of PCM thermal energy storage system to reduce building energy consumption. *Journal of thermal analysis and calorimetry*, 111, 279-288.
- Wang, M., Liu, G., Gao, H., Su, C., & Gao, J. (2023). Preparation and performance of reversible thermochromic phase change microcapsules based on negative photochromic spiropyran. *Colloids and Surfaces A: Physicochemical and Engineering Aspects*, 659, 130808.
- Zhang, Y., Liu, H., Niu, J., Wang, X., & Wu, D. (2020). Development of reversible and durable thermochromic phase-change microcapsules for real-time indication of thermal energy storage and management. *Applied Energy*, 264, 114729.
- Li, Y., Jiang, Z., He, F., Chen, Z., Li, X., Wang, P., ... & Yang, W. (2023). Reversible thermochromic microcapsules with SiO<sub>2</sub> shell for indicating temperature and thermoregulation. *Journal of Energy Storage*, 72, 108674.
- Bašneć, K., Perše, L. S., Šumiga, B., Huskić, M., Meden, A., Hladnik, A., ... & Gunde, M. K. (2018). Relation between colour-and phase changes of a leuco dye-based thermochromic composite. *Scientific reports*, 8(1), 5511.
- Tözüm, M. S., Alay Aksoy, S., & Alkan, C. (2021). Manufacturing surface active shell and bisphenol A free thermochromic acrylic microcapsules for textile applications. *International Journal of Energy Research*, 45(5), 7018-7037.

Li, Y., Yang, A., Li, Y., Jiang, Z., He, F., Chen, Z., ... & Yang, W. (2023). TC@ MF phase change microcapsules with reversibly thermochromic property for temperature response and thermoregulation. *Colloids and Surfaces A: Physicochemical and Engineering Aspects*, 132333.

Özkayalar, S., Adıgüzel, E., Alay Aksoy, S., Alkan, C. (2020). Reversible color-changing and thermal-energy storing nanocapsules of three-component thermochromic dyes, *Materials Chemistry and Physics*, 252, 123162.



## THE MANUFACTURING OF MICROENCAPSULATED PHASE CHANGE MATERIAL INCORPORATED VISCOSE YARNS SUITABLE FOR THERMOREGULATION APPLICATIONS

**Demet YILMAZ**

Prof. Dr. Demet Yilmaz, Süleyman Demirel University, Faculty of Engineering, Department of Textile Engineering, Isparta-Türkiye, (Responsible Author) ORCID: 0000-0003-4450-5935

**Sennur ALAY AKSOY**

Prof. Dr. Sennur Alay Aksoy, Süleyman Demirel University, Faculty of Engineering, Department of Textile Engineering, Isparta-Türkiye, ORCID: 0000-0002-5878-6726

### ABSTRACT

Continuous consumption of non-renewable fossil fuels has led to serious environmental pollution and climate change. Therefore, the effective use of energy has become an important issue and this case forces people to shift towards the use of sustainable and renewable energy. Energy storage technology is a promising method to solve this problem. Therefore, in recent years, researchers focused on various thermal energy storage systems. Particularly, phase change energy storage attracts more interest to realize energy reuse and decarbonization. Today, in textile field, microencapsulated PCMs, which is one of the latent heat storage materials have been integrated into clothing due to their store/release large amounts of energy ability to improve personal thermal comfort and to decrease heat stress in hot indoor and outdoor occupational environments. In this study, poly(methyl methacrylate-co-methacrylic acid) (PMMA-co-MAA) walled, 1-tetradecanol core nanocapsules were produced by emulsion polymerization method and applied to viscose textile fibres during yarn production. PCM integrated viscose ring spun yarns were produced by two different capsule concentrations (3% and 9%) and feeding rate (62.5 mL/h and 80 mL/h) values. Morphological and thermal properties of the produced yarns were analyzed. The results indicated that PCM incorporated yarns provided lower surface temperature values than unloaded reference yarns and temperature differences between unloaded and PCM integrated yarns were beyond 2 °C depending on production parameters such as capsule concentration, feeding rate etc. Textile materials containing PCMs are promising potential for desirable thermal comfort and energy conservation of building heating/air conditioning systems due to their temperature regulating function.

**Keywords:** Thermal energy storage, phase change materials (PCMs), thermoregulating, microcapsules, ring spun yarn, thermal properties

### Introduction

Energy is the source of human life and fossil fuels are the main source of energy. However, the continuous consumption of non-renewable fossil fuels has led to serious environmental pollution and climate change. Therefore, the effective use of energy has become an important issue and this case forces people to shift towards the use of sustainable and renewable energy. Energy storage technology is a promising method to solve this problem. Therefore, in recent years, researchers focused on various thermal energy storage systems. Particularly, phase change energy storage attracts more interest to realize energy reuse and decarbonization. Phase change materials (PCMs), also known as latent heat storage materials, store/release large amounts of energy from the environment during the phase change processes (Chang et al., 2022; Wang et al., 2022). They are capable to improve energy utilization and environmental protection in terms of their high-performance storage function of thermal energy. Therefore, they are widely used in various fields.

Today, in the field of textile, PCMs have been integrated into textile garments to get thermo-regulating and temperature buffering functions for human body. Thermo-regulating of human body has a significant influence on saving energy consumption of building heating, ventilation, and air conditioning (HVAC) systems (Zhao et al., 2021; Peng et al., 2020). HVAC systems constitute excessive energy consumption in buildings,

accounting for nearly 40% of the total energy consumption (Zhu et al., 2021). For example, to maintain the thermal comfort of the human body within an extended heating and/or cooling range of 2 °C, HVAC can realise about 20% of energy savings (Peng et al., 2020; Tabor et al., 2020). With the increase in quality of life and huge effects of climate change, the demand for HVAC has increased and this case has resulted in excessive energy consumption in buildings. On the other hand, the demand of energy for heating and cooling varies on a daily, weekly and even seasonal scale and this case put a great burden on conventional systems. Thereby, development of alternative strategies and technologies of high energy efficiency became a hot topic to decrease energy consumption.

In the textile field, many researches have been carried out on the usage of PCMs and their adaptation to textile materials. Textile materials containing PCMs are classified as smart thermo-regulating textiles. They can adapt to changeable metabolic heat and environmental conditions. They can improve personal thermal comfort and decrease heat stress in hot indoor and outdoor occupational environments (Golbabaei et al., 2022; Yuan et al., 2021).

It can be concluded from the above, PCM integrated textiles can help to improve human body thermal comfort and hence to decrease energy consumption in buildings by reducing the need for heating and cooling of buildings. In this study, it was focused on integration of PCM capsules to viscose textile fibres for the fabrication of woven/knitted fabrics and thereby for the production of adaptive textiles. In literature, PCM integration applications focused on synthetic fiber spinning and wet processes for the woven/knitted fabrics. There are relatively few studies on PCM capsule integration to staple fibers and spun yarns. In recent years, spun yarns attract the attention of researchers due to unique properties of spun yarns such as porous structure, softness, strength, flexibility, bending as well as usability as yarn/fabric forms and working with different fiber types. In these studies, various new spinning methods such as on core-spun, wrap and friction yarn spinning were used and PCM capsules were applied to a core material. PCM integrated core filament was covered and spun with staple fibres (Yu et al., 2022; Lin et al., 2016; Marsal, 2012). Different from these studies, in this study, an alternative method developed by the authors was used (Yılmaz et al., 2022) and PCM capsules were integrated inner structure as well as the outer surface of the yarn via spraying PCMs into open viscose fiber bundle during yarn spinning. In our previous study, poly (methyl methacrylate-co-methacrylamide) walled and n-dodecanol core nanocapsules were applied to viscose fibres at only one capsule concentration (6%) and feeding rate (70 mL/h) values (Yılmaz et al., 2022). In this study, poly(methyl methacrylate-co-methacrylic acid) (PMMA-co-MAA) walled, 1-tetradecanol core nanocapsules were produced by emulsion polymerization method and applied to viscose textile fibres at 3% and 9% capsule concentrations and 62.5 and 80 mL/h feeding rates. Morphological and thermal properties of the produced viscose yarns were characterized. Therefore, in the study, the effect of different capsule types as well as the effect of production parameters (capsule concentration and feeding rate values) on the thermo-regulation property of the yarns was also investigated.

### Materials and Methods

In the study, emulsion polymerization method was used to synthesis of poly(methyl methacrylate-co-methacrylic acid) (PMMA-co-MAA) walled, 1-tetradecanol core nanocapsules. A wall/core ratio of 1/1 was used in the production of nanocapsules. Morphological and thermal properties of the produced were characterized by LEO 440 Computer Controlled Digital Scanning Electron Microscope (SEM) and Differential Scanning Calorimetry (DSC). According to the results, the capsules had ideal spherical morphology, uniform particle sizes varied from 150 nm to 400 nm. Energy storage capacity was 101.7 J/g at 34 °C and a heat dissipation capacity was -101.2 J/g during liquid-solid and solid-solid phase transitions at 35 °C and 26 °C, respectively (Yılmaz & Alay Aksoy, 2022).

In the study, viscose textile fiber was selected due to its widely used in textile products. For the PCM nanocapsule integration, at first, nanocapsule dispersions were prepared at 3 and 9% concentrations, as described in previous study (Yılmaz et al., 2023). Following to preparation process, PCM nanocapsule dispersion was applied to the viscose fiber rovings via a specially designed feeding apparatus during the drafting process of the ring spinning. Two different feeding rates (62.5 mL/h and 80 mL/h) was used for the application PCM nanocapsules to viscose textile fibres and Ne 20/1 ring spun yarns with knitted twist ( $\alpha=3.4$ )



were produced. Yarn production parameters such as draft and spindle speed were kept constant for both feeding rate values during the yarn production.

In order to determine the presence of PCM in the yarn structure, yarn morphological properties were analysed by Scanning Electron Microscope (SEM). To determine the thermoregulation properties of the yarns, thermal properties of the PCM nanocapsule integrated viscose yarns were measured by the Thermal-History (T-History) test method and the changes in surface temperatures of yarn samples were analysed (Yılmaz et al., 2023; Alay et al., 2017). Dynamic temperature regulation feature of the samples was investigated resulting from absorbed latent heat by the nanoencapsulated PCMs in the yarn structure in variable temperature environments.

## Findings and Discussion

### 1) Yarn morphological properties

Figure 1 shows the longitudinal SEM images for PCM integrated viscose ring spun yarns at two different nanocapsule concentrations and feeding rate values. As seen, many nanocapsules were located at interstices between the fibers and on the fiber surface of PCM integrated viscose yarns. A higher numbers of nanocapsules have been observed along the fiber surface of the yarn samples. Some nanocapsules were distributed in the form of conglomerates of various sizes, adhering to the fiber surfaces and they were distributed in clusters along the fibers. As the PCM nanocapsule dispersion feeding rate increased from 62.5 mL/h to 80 mL/h, number of nanocapsules in the yarn structure was getting higher. This case was observed for capsule concentration. There was a significant rise in the number of nanocapsules in the yarn structure as a result of higher amount of PCMs application via production parameters. The presence of capsules was quite apparent in yarns produced at higher feeding rates and capsule concentrations. Cross-sectional images of the yarns samples also indicated the presence of capsules on the fibre surface (Figure 2).

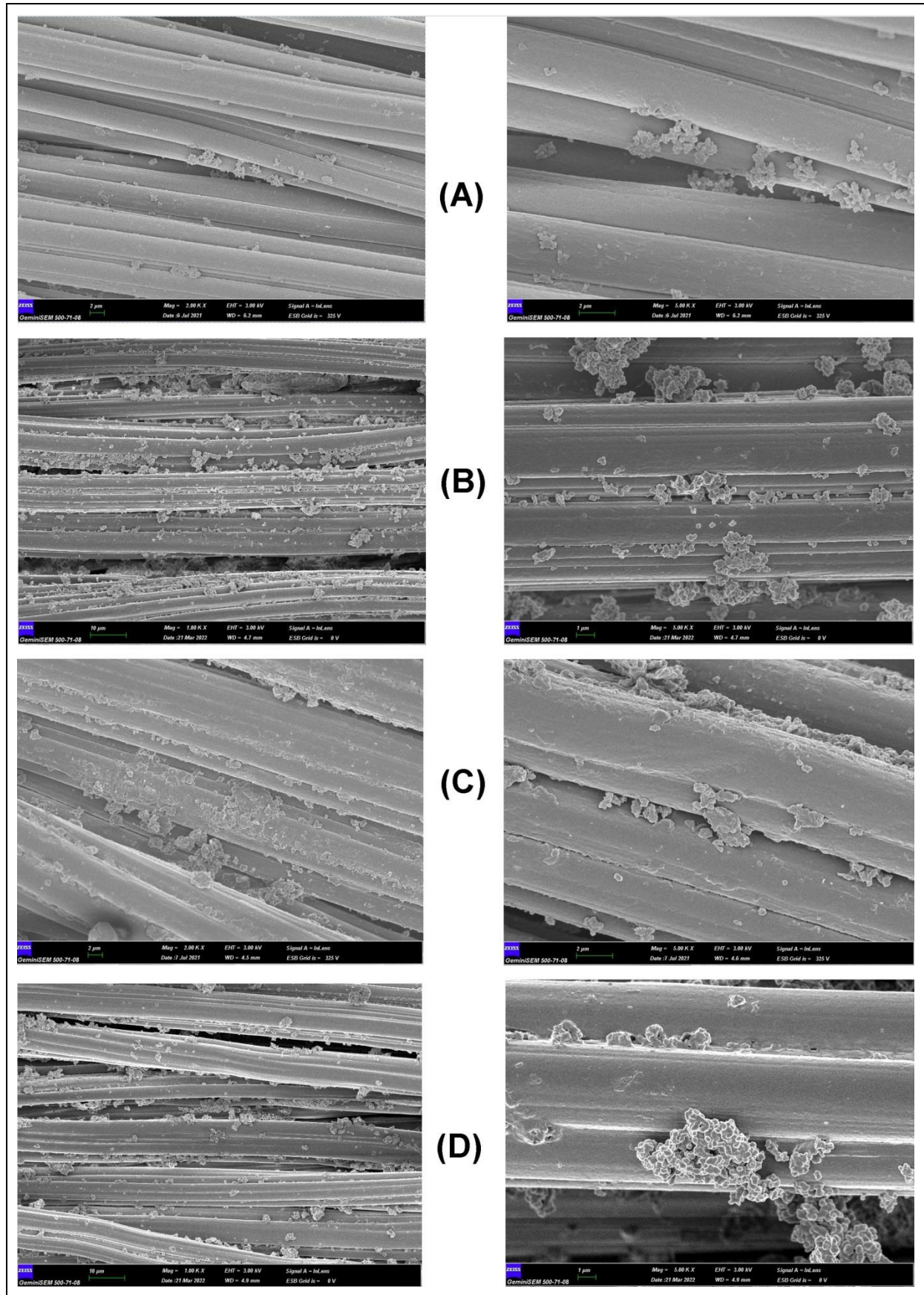

**Figure 1.** SEM images of PCM nanocapsule incorporated viscose yarns for different production parameters (A:3%, 62.5 mL/h, B:3%, 80 mL/h, C:9%, 62.5 mL/h, D:3%, 80 mL/h)

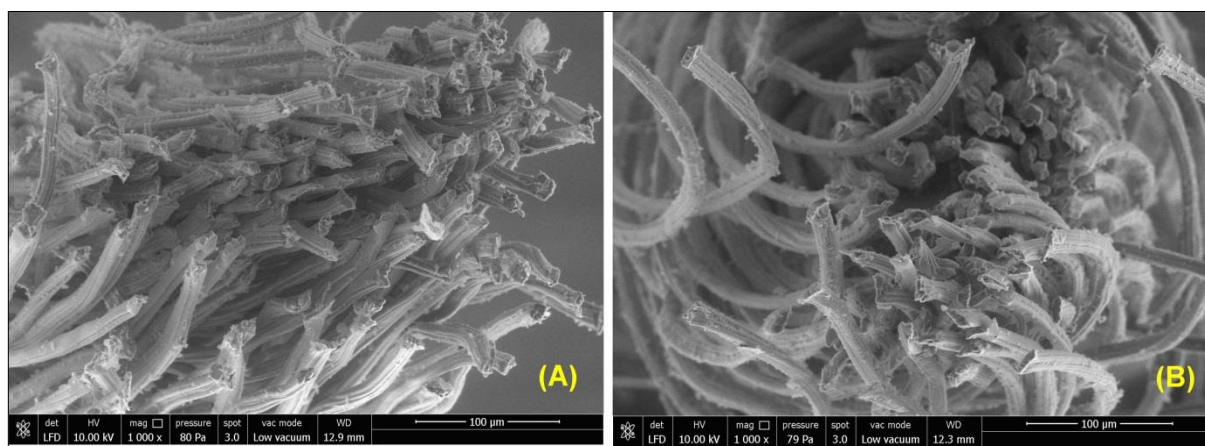

**Figure 2.** Cross-sectional images of PCM nanocapsule incorporated viscose yarns for (A:3%, B:9%)

## 2) Thermal properties of the yarns

Thermal properties of PCM nanocapsule incorporated viscose ring spun yarns were measured by Thermal History (T-History) test method and compared with unloaded reference viscose yarns. The changes in surface temperatures of the yarn samples in variable temperature environments were obtained in the form of T-History curves (Figures 3A, B) and surface temperature values (Tables 1-2) from T-History test method. In the T-history curves, x-axis shows the measurement time while y-axis shows the surface temperature measured on the surface of the yarn sample. According to the T-History test results, all capsule incorporated viscose yarns produced with two different nanocapsule concentrations and feeding rate values had lower surface temperature values compared to unloaded viscose yarns (Figures 3A, B). Hence, PCM-loaded yarns provided a lower surface temperature values.

When the T-history curve for 3% capsule concentration was studied in detail, it was observed that the surface temperature of the yarns without capsules increased more rapidly than PCM integrated yarns (Figure 3A). Temperature values of unloaded reference yarns were higher than that of the PCM integrated yarns during the measurement. When the reference and PCM integrated yarns which were conditioned in a cold environment were taken and placed in a warm insulated box, their temperatures increased rapidly over time. This change was called as the “warming up region” and this case was actually to be expected. During the warming up region, the surface temperature of the yarn without nanocapsules increased rapidly to 22.2 °C in the first 10 minutes, and after this point, it slowly warmed up and reached a maximum of 39.6 °C at the end of the measurement period (1 hour 20 minutes). The surface temperature of PCM integrated yarns increased to 21.5-15.1 °C in the first 10 minutes for 62.5 and 80 mL/h feeding rates, respectively. After this point, it warmed up slowly and reached a maximum of 32.1-34.6 °C at the end of the measurement period. With respect to the analysis results, PCM integrated viscose ring spun yarns gave lower surface temperature values and this case was considered as a cooling effect resulted from PCM in yarn structure.

In the study, the difference values between the surface temperatures of the reference and PCM integrated yarns at different measurement times were analysed (Table 1). According to the results, it was observed that the temperature difference of the yarns without and with capsules was quite high at the 5th minute in the warming up period. Following to the warming up period, the temperatures increased at a lower level and the temperature difference gradually decreased. This temperature change region was called as the “saturated surface temperature region”. In the saturated surface temperature region, the surface temperature values almost remained stable until the end of the measurement period. At the end of the measurement, temperature difference value was about 7.5-5 °C for 62.5 and 80 mL/h feeding rates, respectively. However, mean surface temperature differences at 62.5 mL feeding rate value were about 3.89 °C while it was 5.26 °C at 80 mL feeding rate value. Therefore, 80 mL/h feed rate gave a higher mean surface temperature difference value.

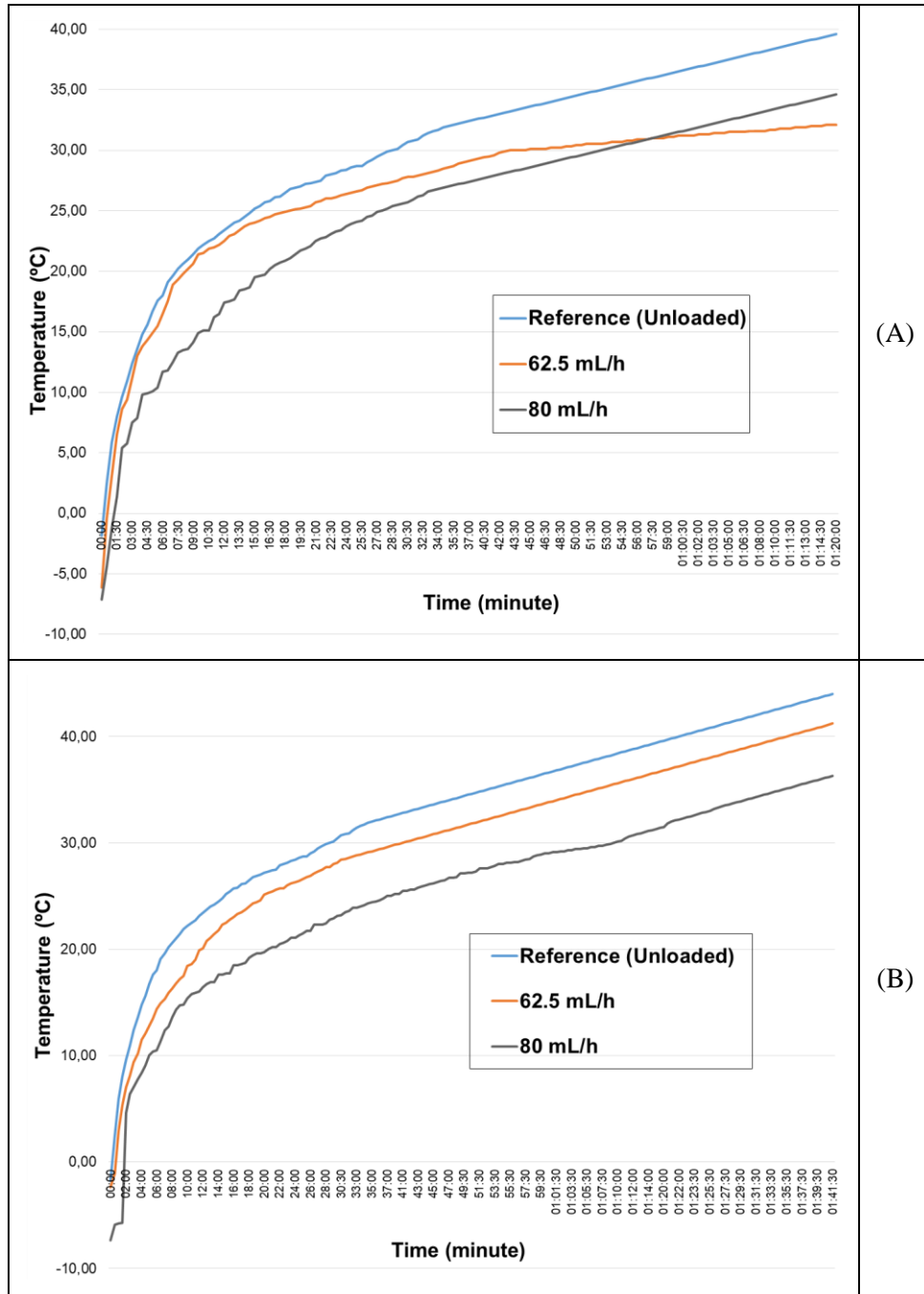

Figure 3. T-history curves of reference (unloaded) and PCM nanocapsule incorporated viscose ring spun yarns at 3% (A) and 9% (B) capsule concentrations

**Table 1.** Differences in surface temperatures (°C) of reference and PCM nanocapsule incorporated viscose yarns at different feeding rates for 3% capsule concentration

Time (min)	Temperature (°C)	
	Feeding rate	
	62.5 mL/h	80 mL/h
05:00	1.80	6.60
10:00	0.70	7.10
15:00	1.20	5.70
20:00	1.90	5.30
25:00	2.10	4.60
30:00	2.70	4.80
35:00	3.40	5.00
40:00	3.30	5.00
45:00	3.50	5.00
50:00	4.10	5.00
55:00	4.70	5.00
01:00:00	5.30	5.00
01:05:00	6.00	5.00
01:10:00	6.70	5.00
01:15:00	7.30	5.00
01:20:00	7.50	5.00

According to the thermal results of 9% capsule concentration, the surface temperature of the PCM integrated viscose yarns increased to 15.4-20.7°C in the first 10 minutes, and after this point, it warmed up slowly and reached a maximum of 31.5-37.4°C at the end of the measurement period. Similar trends were observed at 9% concentration to 3% capsule concentration, following a rapid temperature increase in warming up region, surface temperatures showed a tendency to increase at a lower degree during the saturated surface temperature region. In both regions, PCM integrated yarns gave lower surface temperature values. This result is related to the fact that PCM starts to melt during the temperature increase and absorbs latent heat energy at high capacity during its melting. The latent heat absorbed by the PCM causes the fabric surface temperature to decrease.

When the temperature difference values given in Table 2 were studied, similar trends were observed for 9% concentration. Temperature difference value was about 2.8-7.7 °C at the end of the measurement for 62.5 and 80 mL/h feeding rates, respectively. However, mean surface temperature differences at 62.5 mL feeding rate value were about 2.81 °C while it was 7.56 °C at 80 mL feeding rate value. Therefore, as in 3% concentration, 80 mL/h feed rate gave a higher mean surface temperature difference value.

With respect to the analysis results, the highest feeding rate (80 mL/h) gave higher temperature difference values at both capsule concentrations (Table 3). As the add-on increased by the PCM nanocapsule feeding, number of nanocapsules in the yarn structure inherently rised and this case enhanced higher temperature differences values. Regarding capsule concentration, it was not observed significant differences in surface temperature values of 3% and 9% concentrations. Although slightly higher surface temperature difference values were obtained in the unloaded and PCM integrated yarns at 9% concentration, the most significant effect of the capsule concentration was determined as the variation in the surface temperature difference values. The less variation was determined in 9% concentration than the 3% concentration and surface differences values displayed a more stable variation in 9% (Tables 2-3).

**Table 2.** Differences in surface temperatures (°C) of reference and PCM nanocapsule incorporated viscose yarns at different feeding rates for 9% capsule concentration

Time (min)	Feeding rate	
	62.5 mL/h	80 mL/h
05:00	3.90	6.70
10:00	3.80	6.80
15:00	2.70	7.50
20:00	2.10	7.50
25:00	2.10	7.20
30:00	2.30	7.30
35:00	2.80	7.60
40:00	2.80	7.40
45:00	2.80	7.40
50:00	2.80	7.30
55:00	2.80	7.40
01:00:00	2.80	7.50
01:05:00	2.80	8.00
01:10:00	2.80	8.30
01:15:00	2.80	8.10
01:20:00	2.80	8.10
01:25:00	2.80	7.80
01:30:00	2.80	7.70
01:35:00	2.80	7.70
01:40:00	2.80	7.70
01:41:30	2.80	7.70

**Table 3.** Mean values of the temperature difference results (°C) for different production parameters

Concentration (%)	62.5 mL/h	80 mL/h
3	3.89	5.26
9	2.80	7.56

**Conclusion and Recommendations**

Adaptive textiles with thermoregulation properties are important in terms of energy consumption of building heating/air conditioning systems as well as providing thermal comfort of the person. In this study, it was aimed to integrate poly(methyl methacrylate-co-methacrylic acid) (PMMA-co-MAA) walled, 1-tetradecanol core nanocapsules to viscose textile fibres for the fabrication of woven/knitted fabrics and thereby for the production of adaptive textiles. PMMA-co-MAA walled, 1-tetradecanol core nanocapsules were applied to viscose textile fibres an alternative method and the effects of capsule concentration (3% and 9%) and feeding rate values (62.5 mL/h and 80 mL/h) were investigated. Morphological and thermal measurements indicated that number of nanocapsules in the yarn structure inherently rised as the add-on increased by higher capsule concentration and PCMs feeding rate values. Higher capsule integration into the yarn structure provided less surface temperature values in comparison to unloaded reference viscose yarns. Particularly, similar surface temperature and temperature difference values were determined as the capsule concentration increased. Mean surface temperature differences were about 3.89-5.26 °C for 3% capsule concentration while it was about 2.8-7.56 °C for 9%. The findings of this study including the sufficient latent heat value and suitable transition temperature of PCMs, PCM integrated viscose ring spun yarns would fulfill the thermal management requirements for cooling applications. Produced yarns could serve as a basis for thermal energy storage applications based on textile products.

### Thanks and Information Note

This study is funded by The Scientific and Technological Research Council Of Turkey (TUBITAK), 1505 University-Industry Cooperation Support Program, Project No: 5200098. The authors also would like to thank ADIM Tekstil San. ve Tic. A.Ş. (ISPARTA) for its contribution to the project and study.

### References

- Alay Aksoy, S., Alkan, C., Tözüm, M. S., Demirbağ, S., Altun Anayurt, R. & Ulcay, Y. (2017). Preparation and textile application of poly(methyl methacrylate-co-methacrylic acid)/n-octadecane and n-eicosane microcapsules. *The Journal of The Textile Institute*, 108(1), 30-41.
- Chang, Z., Wang, K., Wu, X., Lei, G., Wang, Q., Liu, H., ... & Zhang, Q. (2022). Review on the preparation and performance of paraffin-based phase change microcapsules for heat storage. *Journal of Energy Storage*, 46, 103840.
- Golbabaei, F., Heydari, A., Moradi, G., Dehghan, H., Moradi, A., & Habibi, P. (2022). The effect of cooling vests on physiological and perceptual responses: a systematic review. *International Journal Of Occupational Safety And Ergonomics*, 28(1), 223-255.
- Lin, J. H., Huang, Y. T., Li, T. T., Lin, C. M. & Lou, C. W. (2016). Bamboo charcoal/ phase change material/stainless steel ring-spun complex yarn and its far-infrared/anion-releasing elastic warp-knitted fabric: Fabrication and functional evaluation. *Journal of Industrial Textiles*, 46, 624-642.
- Marsal Amenós, F. (2012). New method for applying microcapsules in the spinning process. *In International Scientific Conference*, 98-102.
- Peng, Y. & Cui, Y. (2020). Advanced textiles for personal thermal management and energy. *Joule*, 4(4), 724–742.
- Tabor, J., Chatterjee, K. & Ghosh, T. K. (2020). Smart textile-based personal thermal comfort systems: current status and potential solutions. *Advanced Material Techonology*, 5(5),1901155.
- Wang, S., Lei, K., Wang, Z., Wang, H. & Zou, D. (2022). Metal-based phase change material (PCM) microcapsules/nanocapsules: Fabrication, thermophysical characterization and application. *Chemical Engineering Journal*, 438, 135559.
- Yılmaz, D. & Alay Aksoy, S. (2022). Temperature regulating polyester short staple ring spun yarns by PCM nanocapsule application, 8th International Technical Textiles Congress (ITTC 2022), 13-14 October, İzmir, Turkey.
- Yılmaz, D., Özen, Ö., Özkayalar, S., Alay Aksoy, S. & Söğüt, B. (2022). An Innovative Method for Microcapsule Based Functional Yarn Production. *Journal of Natural Fibers* 19(14), 8051-8064.
- Yılmaz, D., Alay Aksoy, S., Maleki, H., Rahbar, R. S., Söğüt, B. & Azimi, S. S. (2023). Fabrication of PCM-loaded polylactic acid (PLA)/cotton biocomposite yarn with thermoregulation function. *Cellulose*, 30, 3995-4009.
- Yu, L., Ke, G., Wang, Y. & Tang, J. (2022). Fabrication and characteristics of polyethylene glyco/cotton friction spun composite yarn. *Journal of Energy Storage*, 48, 103978.
- Yuan, S., Zhang, M. & Zhang, N. (2021). Experimental study on cooling effect and improving comfort of cooling vest. *In IOP Conference Series: Earth and Environmental Science*, 714(4), 042026.
- Zhao, Y., Zhang, X. & Hua, W. (2021). Review of preparation technologies of organic composite phase change materials in energy storage. *Journal of Molecular Liquids*, 336, 115923.
- Zhu, X., Sheng, X., Li, J. & Chen, Y. (2021). Thermal comfort and energy saving of novel heat-storage coatings with microencapsulated PCM and their application. *Energy and Buildings*, 251, 111349.



## EXPLORING HEAT TRANSFER IN GRAPHENE OXIDE NANOFLUIDS AT DIFFERENT FLOW SPEEDS

**Süleyman ŞİŞMAN**

Turkish and German University, Faculty of Engineering, Mechanical Engineering, Beykoz Campus  
ORCID: 0000-0001-6041-7535

**Mehmet İPEKOĞLU**

Turkish and German University, Faculty of Engineering, Mechanical Engineering, Beykoz Campus  
ORCID: 0000-0002-0019-3346

**Cem UÇARKUŞ**

Turkish and German University, Faculty of Engineering, Mechanical Engineering, Beykoz Campus

### ABSTRACT

Nanofluids exhibit superior heat conduction capabilities compared to traditional fluids due to the dispersion of nanoparticles within the fluid, which enhances the heat transfer coefficient. They have potential applications in various engineering fields such as heat exchangers, cooling systems, solar energy collection systems, nuclear reactors, and electronic device cooling. Graphene oxide nanoparticles are preferred for their stable dispersion in fluids. In this study, an investigation of a system containing graphene oxide nanoparticles was conducted across a wide range of flow velocities using two different approaches single-phase, two-phase flow methods. The obtained results were compared with independent research conducted by other scholars, and performance analyses related to the field of graphene oxide were extracted.

**Keywords:** graphene oxide, heat transfer, nanofluid

### Introduction

Energy efficiency is gaining increasing importance in today's world. Given the limited energy resources and their environmental impacts, effective energy transfer and storage have become a significant necessity. In this context, nanofluids exhibit superior heat conduction capabilities compared to traditional fluids. This superior performance is attributed to the homogeneous dispersion of nanoparticles within the fluid, which enhances the heat transfer coefficient. Nanofluids have potential applications in various engineering fields such as heat exchangers, cooling systems, solar energy collection systems, nuclear reactors, and electronic device cooling.

Graphene oxide nanoparticles, in particular, are preferred due to their ability to stably disperse within the fluid. In 2020 Karabulut et al. emphasizes the importance of investigating heat transfer properties alongside thermophysical characteristics for the use of nanofluids in engineering applications. It examines the convection heat transfer coefficient of graphene oxide-distilled water nanofluid along a circular copper tube with turbulent flow conditions, both numerically and experimentally. The showcases the performance of nanofluids in terms of convection heat transfer under different volumetric flow rates, concentrations, and heat flux values. It is observed that the nanofluid with 0.02 vol% concentration exhibits approximately a 48% increase in heat transfer coefficient compared to distilled water. They have suggested the potential use of this nanofluid as an efficient alternative in cooling and heating applications [1]. Azimi et al, studied about nanoparticles. They have researched encompassing a wide range of nanomaterials, including nanocrystalline materials, nanocomposites, carbon nanotubes, and quantum dots. Nanofluids, representing fluids containing nanometer-sized particles, are investigated, particularly those containing hydrogen exfoliated graphene (HEG), to examine their thermal conductivity and heat transfer properties. The results reveal significant enhancements in thermal conductivity and Nusselt number for these nanofluids. Furthermore, the study explains four mechanisms contributing to thermal conduction in nanofluids: ballistic heat transport in nanoparticles, Brownian motion, liquid layering at liquid/particle interfaces, and nanoparticle clustering. The research also applies the Galerkin Optimal



Homotopy Asymptotic Method to find semi-analytical solutions for unsteady nanofluid flow and heat transfer between moving plates, offering practical insights for industries such as chemical engineering and polymer processing by emphasizing the potential of nanofluids in heat transfer [2]. In 2022 Fujimoto et al, focused on a novel production method that enables the rapid and cost-effective production of graphene nanofluids in large quantities. It has investigated the turbulent heat transfer performance of graphene nanofluids in a horizontal circular tube both experimentally and numerically. The results demonstrate an enhancement in turbulent heat transfer performance for graphene nanofluids produced using pulsed discharge and ultrasonic treatment. Numerical simulations reveal significant changes in turbulent kinetic energy, velocity gradients near the tube wall, and temperature distribution due to the physical interactions between graphene nanoparticles and the continuous phase. It studied underscores the importance of considering particle shape and microscopic particle motion when accurately modeling graphene nanofluids in future numerical studies [3]. Azimi et al. studied using neural network method in nanofluids, The heat transfer of two dimensional Graphene Oxide water-based nanofluids between two moving parallel plates was examined using an intelligent black-box identifier. This intelligent tool, called an evolvable evolutionary fuzzy inference system (EE-FIS), integrates evolutionary computing and fuzzy logic concepts. The authors propose the use of a modified evolutionary algorithm known as the hybrid genetic mutable smart bee algorithm (HGMSBA) to evolve the antecedent and consequent parts of the fuzzy rule base, aiming to reduce computational complexity and enhance interpretability. The results demonstrate that HGMSBA-FIS is a suitable tool in terms of accuracy and robustness, applicable to real-time applications like model-based control [4]. Aman et al. studied in 2018, graphene nanofluid in solar application. It has been conducted mixed convection flow in a channel, especially in fields like thermal and nuclear power engineering, has attracted significant attention. Mixed convection in channel flow arises due to the cooling/heating of the channel walls. Some of the previous studies analyzing such flows have considered factors like the effect of a magnetic field, radiative heat transfer of optically thin fluids passing through channels filled with porous media, and heated bounding walls. Additionally, the concept of suspending solid particles in base fluids to improve thermal conductivity has been proposed. However, very few studies have explored the effects of fractional derivatives on nanofluids. The aim of this study is to utilize fractional derivative models to obtain exact solutions for the mixed convection flow of graphene nanofluids past a vertical plate, thus enhancing heat transfer rates and gaining insights into the problem through graphical analysis [5]. In 2021, Manderra et al. focused on nanofluid application of radiators used in engine cooling systems. Radiators are vital components responsible for transferring thermal energy between different fluids. Traditional cooling methods involved using fins on radiators to improve cooling capacity, but this approach became less effective as radiators grew in size. To address this issue and improve engine efficiency, the study explores the use of nanofluids, specifically Graphene-based Nanofluids (Graphene and Graphene Oxide), to enhance heat transfer in radiators. Graphene-based nanofluids, enthalpy enhancement (58–60%), heat transfer coefficient improvement (236% to 320%), and increased entropy (1.8%) are also observed with the louvered strip. The research demonstrates that the insertion of a louvered strip in radiators using Graphene-based nanofluids at optimal concentrations enhances radiator performance [6].

The aim of this study is to investigate the effect of graphene oxide nanoparticles, which are a promising nanofluid alternative due to their non-toxicity and potential for reuse, on heat conduction at different velocities. Nanofluids exhibit superior heat conduction capabilities compared to traditional fluids because the dispersion of nanoparticles within the fluid enhances the heat transfer coefficient. Graphene oxide nanoparticles are preferred for their stable dispersion.

### Materials and Methods

The examinations were conducted for pipe flow with a constant heat flux. Thermal analyses were numerically performed for graphene oxide nanoparticles with a concentration of 0.01%. The studied system is presented in Figure 1. The investigations were carried out numerically using the finite volume method with ANSYS Fluent software.

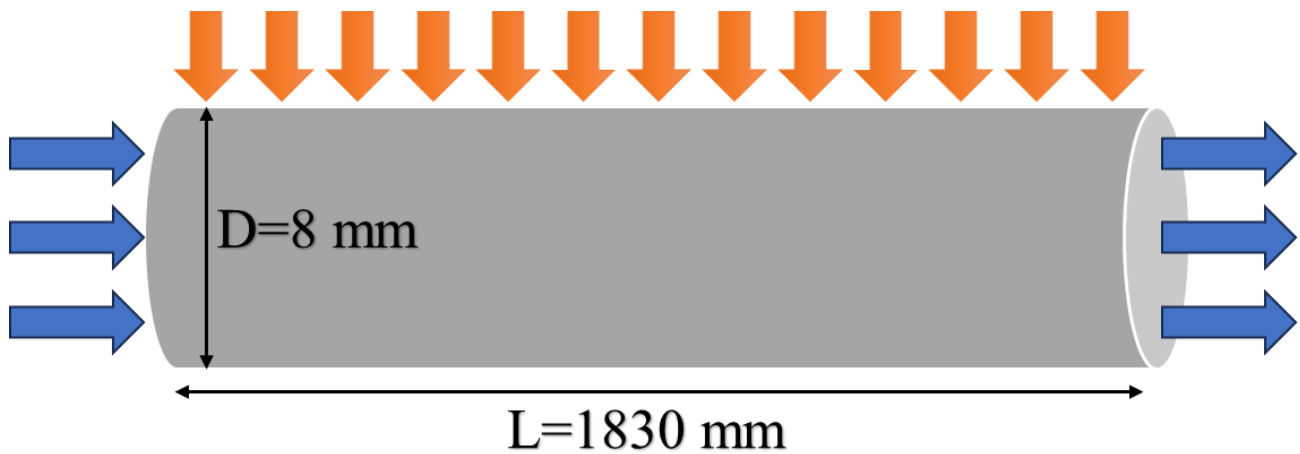

Figure 1 Numerical investigated thermal system

In the realm of numerical analyses, conducting a grid independence study holds pivotal importance. This essential step involves the comparison of outcomes across various grid configurations to verify whether the results remain unaffected by changes in grid resolution. This investigative process is instrumental in pinpointing the optimal grid resolution required to attain precision and reliability in the study's findings. In the context of the present study, a thorough grid independence test was executed, incorporating varying numbers of elements. It's worth noting that a total of 33,600 elements were thoughtfully selected for this purpose, and the results are depicted in Figure 2.

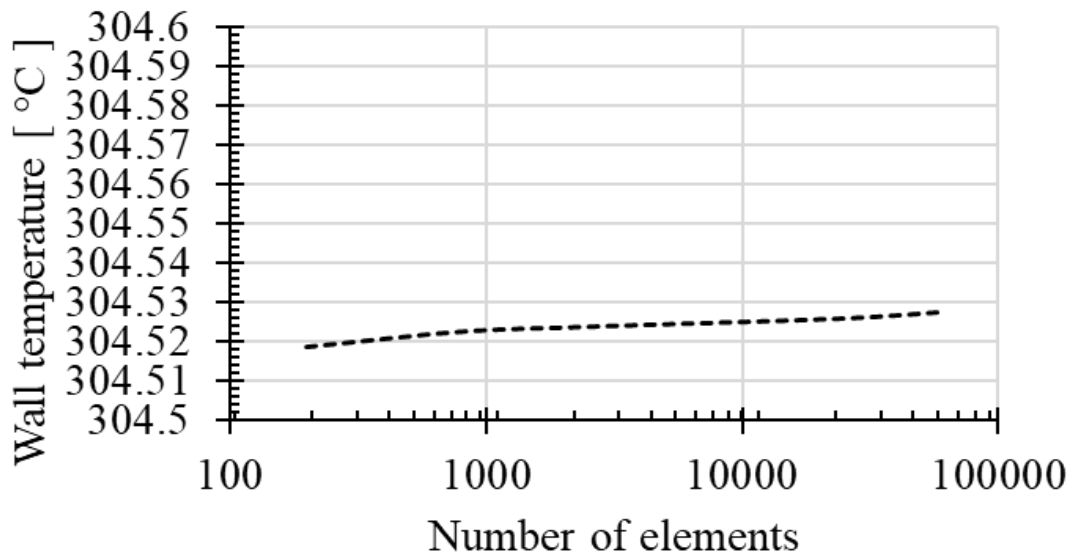

Figure 2 Grid Independence Test Results

The validation process involves comparing numerical models with real-world phenomena using actual experimental data to determine their accuracy. Experimental validation is a critical step in assessing the impact of numerical analyses on design and engineering decisions, contributing to the attainment of reliable results in engineering applications. In this study, the numerical results were compared to the experimental study conducted by Karabulut et al. in 2020. The results, as shown in Figure 3, demonstrate a high level of agreement,

with error bars below 5 percent, indicating a strong correlation between the numerical simulations and the experimental data.

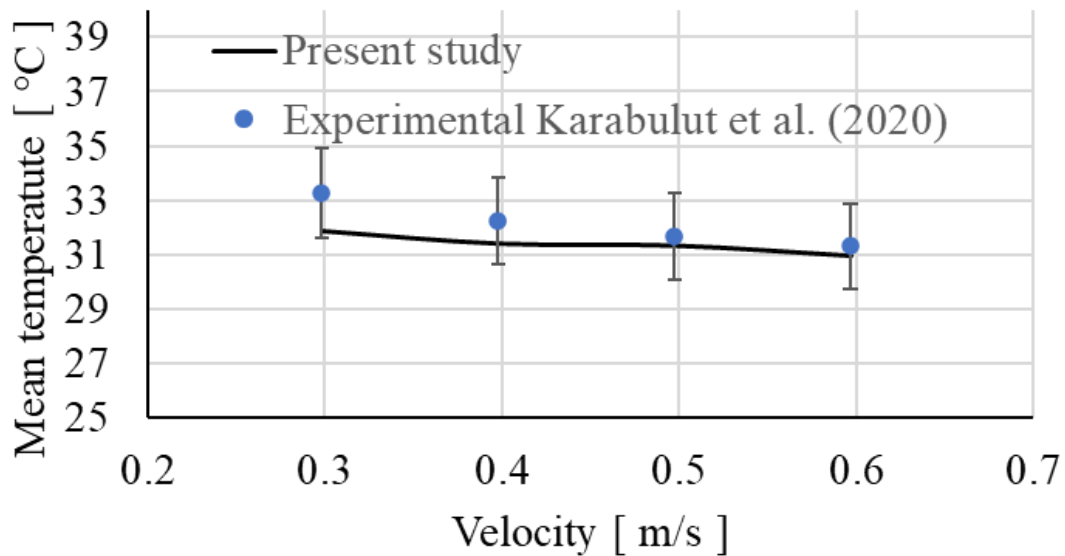

Figure 3 Comparison of Numerical Results with Experimental Data (Karabulut et al., 2020)

**Findings and Discussion**

Upon comparing the temperatures of the outlet wall with the average fluid temperature, it was observed that an increase in velocity led to a decrease in wall temperature while the average temperature increased. This phenomenon can be elucidated by the heightened heat transfer coefficient, signifying more efficient heat flux transfer to the fluid. The achievable temperature values for different velocities are presented in Figure 4. These values can be utilized to make predictions about the temperatures within a system containing nanoparticles.

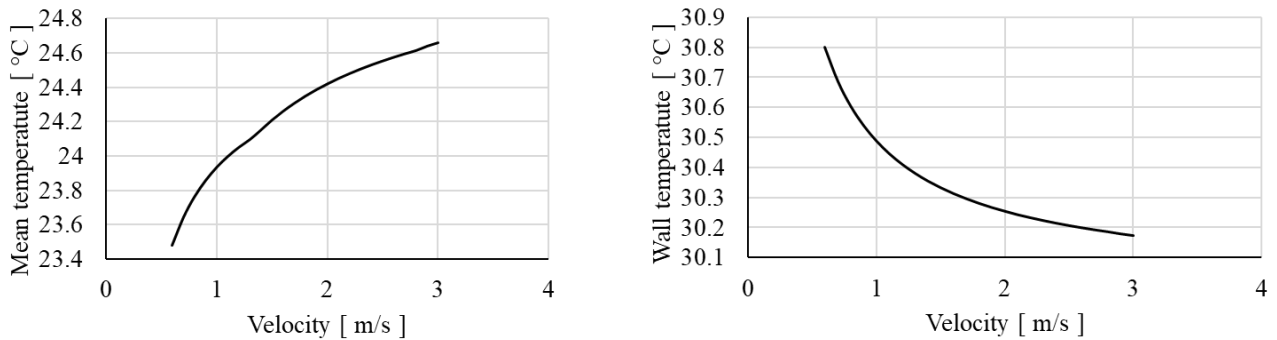

Figure 4 The variation of mean temperature and wall temperature with different velocity values.

The figure 5 displays a comparative analysis of numerical results for the convection heat transfer coefficient at varying velocities (specifically, 3623.746 W/m<sup>2</sup> or 250 W) between pure water and a 0.01% GO nanofluid.

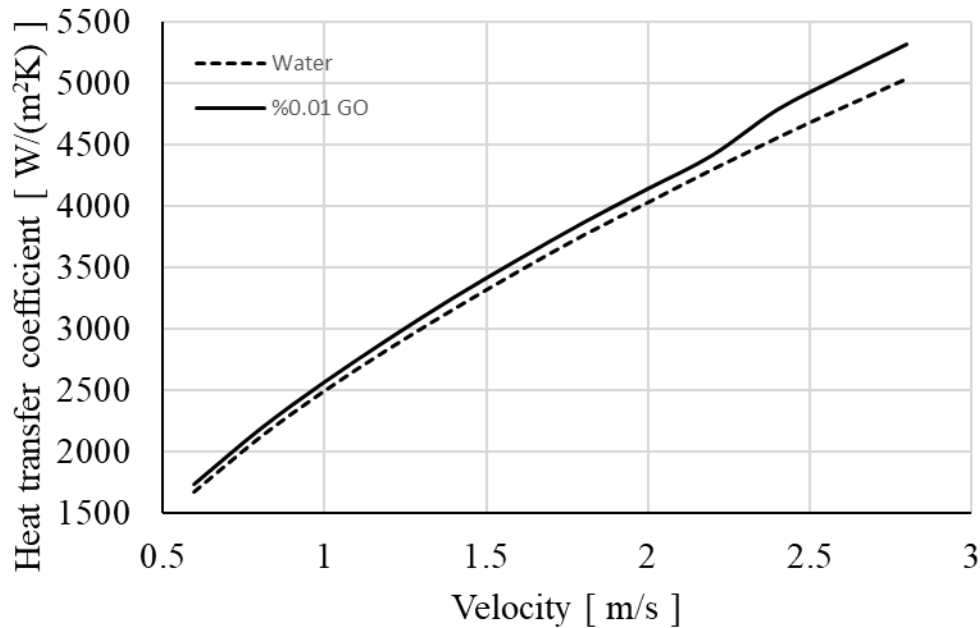

Figure 5 The temperature difference between pure water and nanofluid at different velocities.

### Conclusion and Recommendations

This present study has shed light on the promising potential of graphene oxide nanoparticles as an efficient heat transfer enhancement agent in nanofluids. The investigation, which covered a wide range of flow velocities using both single-phase and two-phase flow methods, demonstrates that nanofluids containing graphene oxide nanoparticles exhibit significantly improved heat conduction properties compared to traditional fluids. The figure presented in this study (Figure 5) provides a clear representation of the numerical results, showcasing the enhanced convection heat transfer coefficient achievable with a 0.01% graphene oxide nanofluid. These findings hold great significance, particularly in the context of engineering applications such as heat exchangers, cooling systems, and renewable energy systems, where maximizing heat transfer efficiency is paramount.

Based on these results, we recommend further research to explore the optimization of graphene oxide nanofluids in real-world applications. Additionally, the potential benefits of this nanomaterial in various engineering fields, including nuclear reactors and electronic device cooling, warrant continued investigation.

Overall, the use of graphene oxide nanoparticles in nanofluids shows promise as a viable and sustainable solution for improving heat transfer performance and energy efficiency in a wide range of applications.

### Resources

- [1] Karabulut, Koray, Ertan Buyruk, and Ferhat Kilinc. "Experimental and numerical investigation of convection heat transfer in a circular copper tube using graphene oxide nanofluid." *Journal of the Brazilian Society of Mechanical Sciences and Engineering* 42.5 (2020): 230.
- [2] Azimi, Mohammadreza, Alireza Azimi, and Masoomeh Mirzaei. "Investigation of the unsteady graphene oxide nanofluid flow between two moving plates." *Journal of Computational and Theoretical Nanoscience* 11.10 (2014): 2104-2108.
- [3] Fujimoto, Kotaro, Aima Shibata, and Shuichi Torii. "An experimental and numerical study of turbulent heat transfer enhancement for graphene nanofluids produced by pulsed discharge." *International Journal of Thermofluids* 16 (2022): 100219.
- [4] Azimi, Mohammadreza, and Ahmad Mozaffari. "Heat transfer analysis of unsteady graphene oxide nanofluid flow using a fuzzy identifier evolved by genetically encoded mutable smart bee algorithm." *Engineering Science and Technology, an International Journal* 18.1 (2015): 106-123.
- [5] Aman, Sidra, et al. "A new Caputo time fractional model for heat transfer enhancement of water based graphene nanofluid: An application to solar energy." *Results in physics* 9 (2018): 1352-1362.
- [6] Madderla, Sandhya, et al. "Heat transfer performance of a radiator with and without louvered strip by using Graphene-based nanofluids." *Journal of Thermal Engineering* 7.6 (2021): 1315-1328.



**SYNTHESIS and CHARACTERIZATION of A P(VCL-co-MA) COPOLYMER AS A  
THERMOTROPIC MATERIAL**

**Nazan Gökşen Tosun**

Dr., Tokat Gaziosmanpaşa University, Tokat Vocational School of Health Services, Department of Medical Services and Techniques,  
Tokat-Türkiye, (Responsible Author) ORCID: 0000-0001-5269-1067

**Erdinç Halis Alakara**

Research Assistant, Tokat Gaziosmanpaşa University, Faculty of Engineering and Architecture Department of Civil Engineering,  
Tokat-Türkiye, ORCID: 0000-0001-7925-4190

**Cemil Alkan**

Prof. Dr., Tokat Gaziosmanpaşa University, Faculty of Science and Letter, Department of Chemistry, Tokat-Türkiye  
ORCID: 0000-0002-1509-4789

**ABSTRACT**

Poly (n-vinyl caprolactam) (PVCL) is a well-known material for its thermotropic properties. It is also known that it is possible to adjust phase transition temperature to upper degrees of temperature by incorporating it with hydrophobic monomers. Methyl acrylate is one of the monomers that has not been used for this purpose. In the present study, a copolymer, poly (n-vinyl caprolactam-co-methyl-acrylate) (P(VCL-co-MA)) has been produced and tested for the phase transformation characteristics and thermotropic properties. FT-IR and UV-visible spectroscopy, turbidity measurements, and polarized optical microscopy investigations have been used for characterization. As a result of the investigations, it was found that the copolymerization resulted in an increase in thermal transformation temperature as expected. That is, the temperature could be adjusted by hydrophobic comonomer addition. The presented material system was tested for performance in building energy management systems.

**Keywords:** thermotropic material, thermal energy storage material, vinyl caprolactam.

**Introduction**

Polymers that can respond to environmental changes like pH, temperature, ionic strength, etc. are called as smart or stimuli-responsive polymers. Smart or stimuli-responsive polymers have recently attracted considerable attention due to their application possibility in construction, textiles, and micro/nano encapsulation and controlled release (Kieviet, Schön, and Vancso 2014; Roy and Gupta 2003).

Thermo-responsive polymers are smart materials that are affected physically or chemically by changes in environmental temperature. A phase transition occurs in solution of these materials at the switching temperature which is called as the critical solution temperature (LCST) in a sample case. Solution of these materials is transparent below LCST, as it is opaque above the LCST, that is, hydrophilic polymer changes its statue hydrophobic collapsing in nanoparticles form (Qiu and Park 2001).

Poly (N-isopropyl acrylamide) (PNIPAM) is the most remarkable among thermo-responsive polymers due to its LCST of 32°C. Although the LCST (34°C) of poly (vinyl caprolactam) (PVCL) is similar to the LCST of PNIPAM, it has been more biologically evaluated due to its higher biocompatibility (Cortez-Lemus and Licea-Claverie 2016; Rao, Rao, and Ha 2016).

PVCL is one of the most studied polymers exhibiting LCST behavior at around 34°C. In addition to the temperature-responsive properties of PVCL polymer, many novel copolymers have been produced using many hydrophilic and hydrophobic monomers as shown in Figure-1 to add new properties.

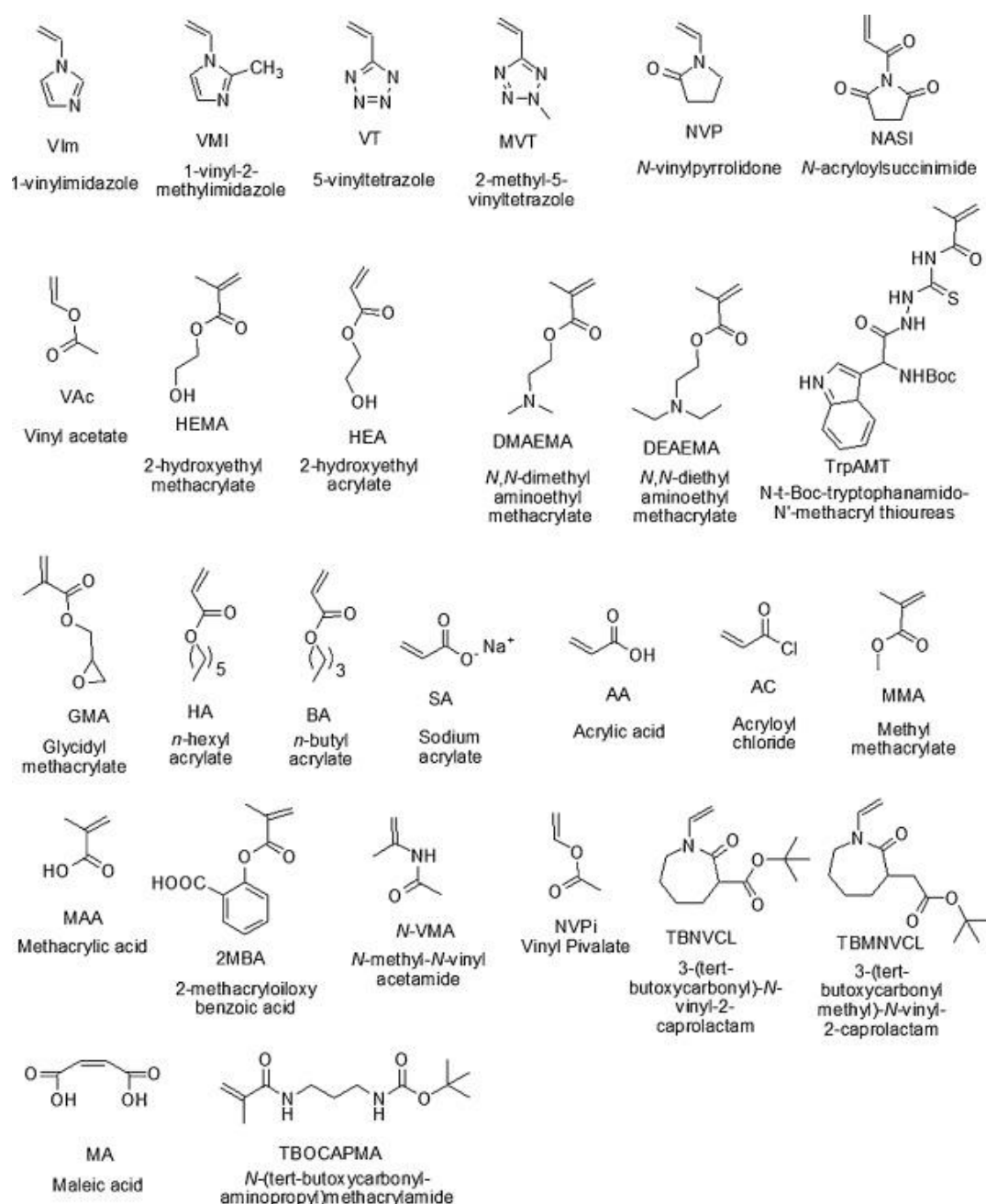

**Figure 1.** Hydrophilic and hydrophobic monomers forming copolymers with VCL (Cortez-Lemus and Licea-Claverie 2016)

Here, for the first time, vinyl caprolactam (VCL) and methyl acrylate (MA) monomer were polymerized together to produce a new temperature-responsive copolymer. Poly (vinyl-co-methyl acrylate) (P(VCL-co-MA)) produced by the free radical polymerization method was chemically characterized by Fourier-transform (FT-IR) spectroscopy. Its physical characterization was carried out by UV-visible spectroscopy, and polarized optical microscopy. Additionally, the LCST behavior of this copolymer was determined by turbidity analysis.

## Materials and Methods

### Materials

Vinyl caprolactam (VCL), methyl acrylate (MA), and 2,2'-azobis (2-methylpropionitrile) (AIBN) were all purchased from Sigma-Aldrich. Toluene and diethyl ether (Merck) were used as solvent.

### Synthesis of P(VCL-co-MA)

P(VCL-co-MA) was synthesized by free radical polymerization using toluene as a solvent (González and Frey 2017). A three-necked round-bottom flask equipped with a reflux condenser was used for the reaction which was carried out under N<sub>2</sub> flow. Firstly, VCL and MA (5%) monomers were dissolved in toluene then the temperature was adjusted at 70 °C. AIBN was added to the reaction medium as an initiator and dissolved in toluene before addition. Finally, the mixture was left to react at 70 °C for 5 hours. The reaction was concluded by bringing the medium to room temperature and adding diethyl ether to the medium to precipitate the copolymer. Isolation of the copolymer was achieved by vacuum filtration and dried at 40°C under vacuum overnight. The scheme of synthesis was given in Figure 2.

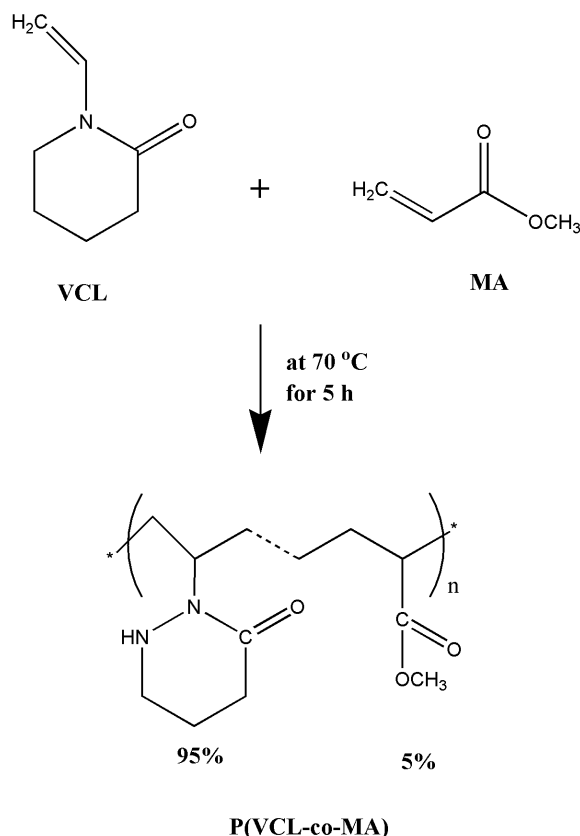

**Figure 2.** The scheme of synthesis P(VCL-co-MA)

### FT-IR Spectroscopy

The chemical characterization of P(VCL-co-MA) was performed by FT-IR spectroscopy (instrument model Jasco 430). P(VCL-co-MA) was scanned by FT-IR at a wavenumber range of 400-4000 cm<sup>-1</sup>.

### UV-Visible Spectroscopy

Determining the absorbance peak of the material at room temperature is an important assay for the LCST analysis. Firstly, P(VCL-co-MA) was dissolved in distilled water to prepare a 1% (v/v) solution. The absorbance peak of the P(VCL-co-MA) solution was measured by UV-visible spectroscopy in the wavelength range of 200-800 nm.

### Microscopy Investigation

Surface crystalline morphologies of vinyl caprolactam and P(VCL-co-MA) were observed using Leica Polarized Optical Microscopy DM EP (Germany, 2010).



### LCST by Turbidity Investigation

LCST of the P(VCL-co-MA) copolymer was measured by turbidity method using a Spectrofluorometer (Jasco FP-8300) instrument (Abdelaty 2022). After preparing 1% (v/v) P(VCL-co-MA) solution, the maximum emission and excitation peaks of the solution were measured as 200.8 nm and 283.8 nm, respectively. Then, the solution was heated at 2 °C /min and scanned in the 200-800 nm wavelength range to perform a graph of intensity versus temperature.

### Findings and Discussion

FTIR spectroscopy is a frequently used method to determine the structural determination of polymers (Riaz and Ashraf 2014). Polymer analyzes sometimes cannot be done with NMR Spectroscopy due to the solubility problem. Additionally, many unexplained peaks can be seen for polymers in NMR methods. Besides NMR techniques are not applicable for thermoset or highly crosslinked polymers (Cheng and English 2002). The FTIR Spectroscopy method was applied to prove polymerization of both monomers in this study. For this reason, both monomers: VCL and MA, and the produced copolymer were compiled in the same figure (Figure 3). In FTIR analyzes of copolymers, it is investigated whether the characteristic peaks of the co-monomers used are present together in the copolymer spectrum. In the present situation, VCL is the main element of the copolymer and the peaks from VCL persisted as the peaks from the methyl acrylate were weak. However, the characteristic peaks of both monomers were there in the copolymer. Some with minor changes better proved polymerization. As another point, it is examined whether the double bond peaks of vinyl monomers generally observed in the range of 1600-1650  $\text{cm}^{-1}$  is there or not (Sun and Wu 2011). Actually, double bond peaks of both monomers are not observable and therefore their disappearance cannot be proven.

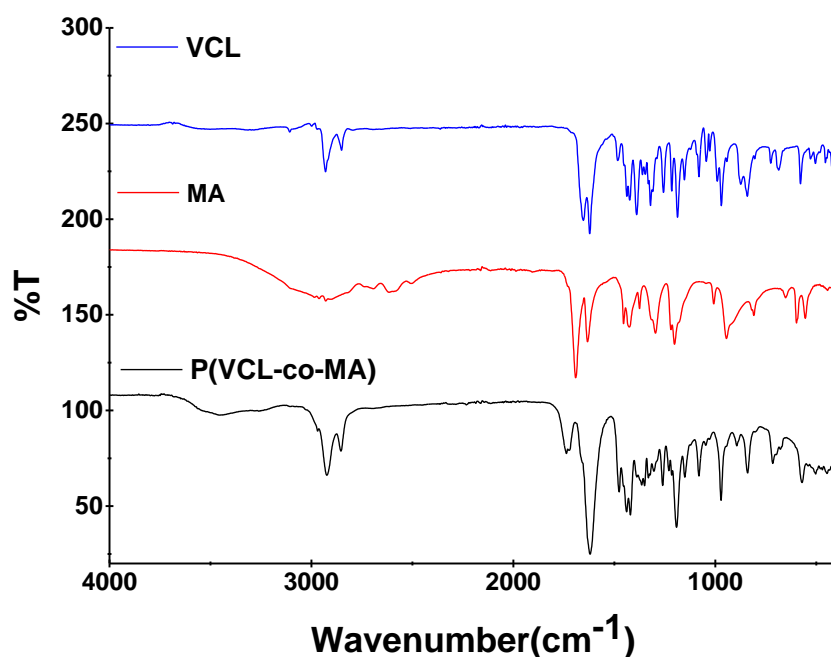

**Figure 3.** The FT-IR spectra of P(VCL-co-MA)

UV-Visible spectra are often used in polymer solutions to show whether polymers have functional groups like double bonds, nitrates, amines, chromophores, etc. (Mujahid and Dickert 2012). Figure 4 presents UV-Visible spectrum of P(VCL-co-MA). As shown in the Figure, the polymer, which is transparent in solution, does not have any peaks in the visible region. The only peak shown in the UV region at a very low wavelength is because of the other chemical groups generally not commented in UV-Visible investigations.

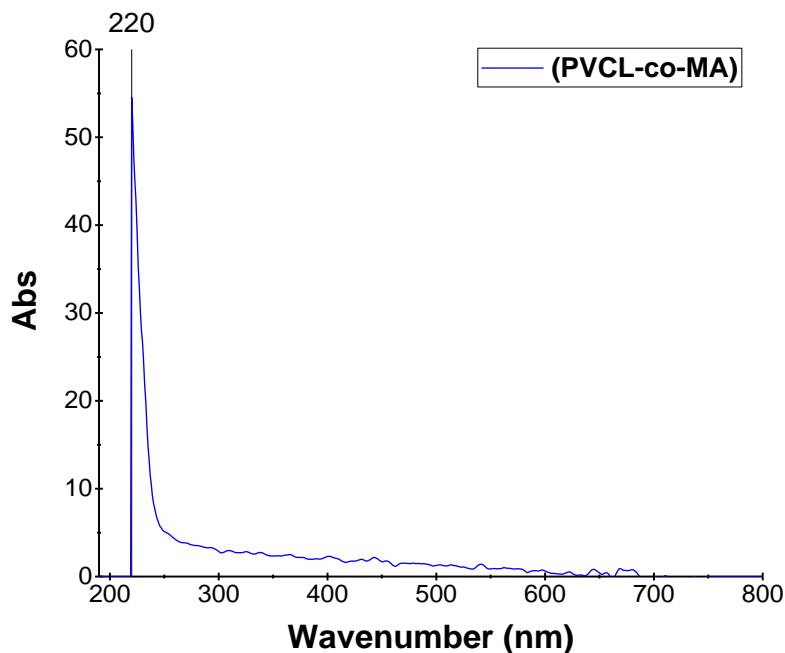

**Figure 4.** The UV-visible analysis of P(VCL-co-MA)

The LCST of 1% P(VCL-co-MA) copolymer solution was tested for the temperature-dependent absorbance change, that is, by the turbidity method. The turbidity curve drawn was shown in Figure 5. The LCST of P(VCL-co-MA) copolymer solution is lower than the LCST of PVCL homopolymer solution (around 34 °C), which is because that MA's hydrophobic structure made it easier for the chains of the copolymer to stretch. It is well-known that hydrophobic monomers decrease the thermotropic polymers response temperature (Xie, Li, and Chu 2007). The comonomer ratio determines the working temperature. The copolymer with 5/95 monomer ratio fitted perfectly for the building energy management application considered as potential application. Changes depending on the MA content in the copolymer is always in the same direction. To the best of our knowledge there is no threshold about these change in the literature.

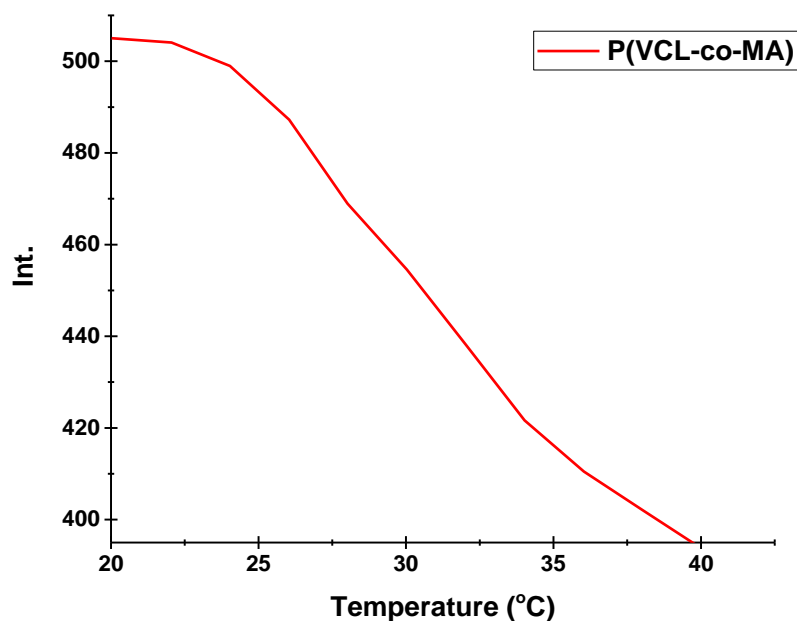

**Figure 5.** The turbidity analysis of P(VCL-co-MA)

Microscope analysis is known as an advanced form of image analysis performed on the polymers due to the light polarization and different illumination angles (Sawyer, Grubb, and Meyers 2008). These structures are often seen to track temperature-dependent spherulitic structures. However, in our study, it was evaluated that PVCL polymer has an amorphous structure. It is also more brittle than the P(VCL-co-MA) in bulk. Figure 6 shows general appearances from both, and it is clearly seen that the copolymer had a tough material form.

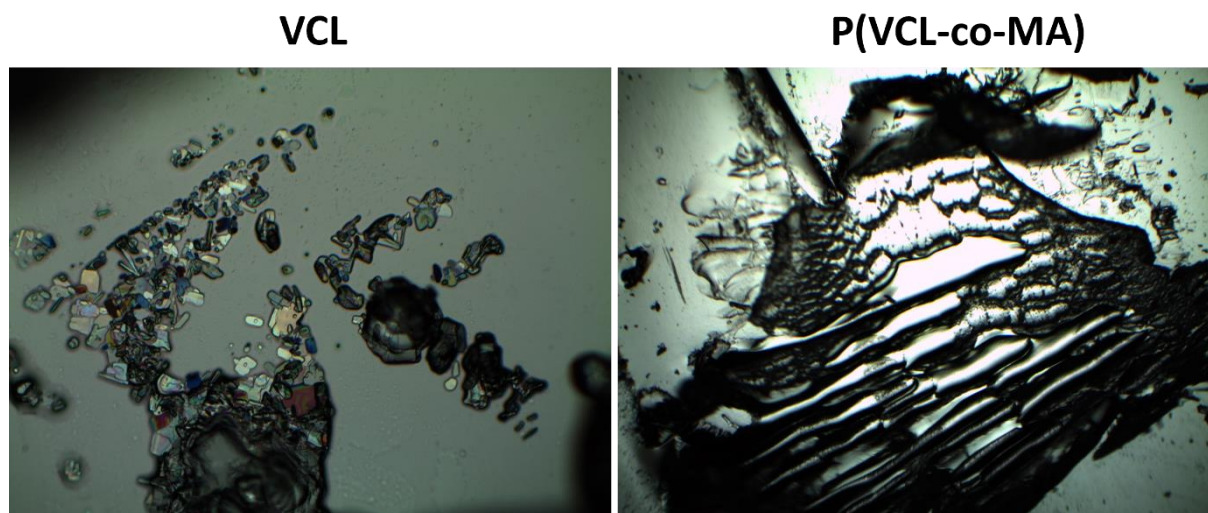

**Figure 6.** Microscopy images of VCL and P(VCL-co-MA)

### Conclusion and Recommendations

In this study, P(VCL-co-MA) copolymer was successfully synthesized and characterized for the first time as a new thermo-responsive material in solution. It was determined that the MA monomer used in copolymer

synthesis reduced the LCST of the polymer system. Thus, the new smart copolymer with reversible transformation property forms transparent to opaque during heating or opaque to transparent during cooling to adapt building energy management system.

FTIR spectroscopy was used to analyze the chemical structure of P(VCL-co-MA) copolymer, as functional property analysis was done by UV-vis spectroscopy and turbidimetry. Polarized optical microscopy was also operated to monitor physical appearance of PVCL and P(VCL-co-MA) copolymer. The unique properties offered by this new copolymer material may be shown as a promising candidate for thermo-responsive smart materials for building energy management systems.

### Thanks, and Information Note

The authors would like to thank the scientific and technological council of Türkiye (Project number: 5160100) and Royal Academy of Engineering (TSP2021/100194) for financial support for this work.

### References

- Abdelaty, Momen S A. 2022. "The Influence of PH/Salt Concentrations on Tuning Lower Critical Solution Temperature of Poly(NIPAAm-Co-DMAA-Co-DTBAVA) Multi-Environmentally Terpolymer." *Journal of Polymers and the Environment* 30 (10): 4130–45. <https://doi.org/10.1007/s10924-022-02502-5>.
- Cheng, H. N., and Alan D. English. 2002. "Advances in the NMR Spectroscopy of Polymers: An Overview." *ACS Symposium Series* 834: 3–20. <https://doi.org/10.1021/bk-2003-0834.ch001>.
- Cortez-Lemus, Norma A, and Angel Licea-Claverie. 2016. "Poly(N-Vinylcaprolactam), a Comprehensive Review on a Thermoresponsive Polymer Becoming Popular." *Progress in Polymer Science* 53: 1–51. <https://doi.org/https://doi.org/10.1016/j.progpolymsci.2015.08.001>.
- González, Eburne, and Margaret W Frey. 2017. "Synthesis, Characterization and Electrospinning of Poly(Vinyl Caprolactam-Co-Hydroxymethyl Acrylamide) to Create Stimuli-Responsive Nanofibers." *Polymer* 108: 154–62. <https://doi.org/https://doi.org/10.1016/j.polymer.2016.11.053>.
- Kieviet, Bernard D, Peter M Schön, and G Julius Vancso. 2014. "Stimulus-Responsive Polymers and Other Functional Polymer Surfaces as Components in Glass Microfluidic Channels." *Lab on a Chip* 14 (21): 4159–70. <https://doi.org/10.1039/C4LC00784K>.
- Mujahid, Adnan, and Franz L Dickert. 2012. "Chapter 6 - Molecularly Imprinted Polymers for Sensors: Comparison of Optical and Mass-Sensitive Detection." In , edited by Songjun Li, Yi Ge, Sergey A Piletsky, and Joseph B T - Molecularly Imprinted Sensors Lunec, 125–59. Amsterdam: Elsevier. <https://doi.org/https://doi.org/10.1016/B978-0-444-56331-6.00006-2>.
- Qiu, Yong, and Kinam Park. 2001. "Environment-Sensitive Hydrogels for Drug Delivery." *Advanced Drug Delivery Reviews* 53 (3): 321–39. [https://doi.org/https://doi.org/10.1016/S0169-409X\(01\)00203-4](https://doi.org/https://doi.org/10.1016/S0169-409X(01)00203-4).
- Rao, Kummara Madhusudana, Kummari Subba Venkata Krishna Rao, and Chang-Sik Ha. 2016. "Stimuli Responsive Poly(Vinyl Caprolactam) Gels for Biomedical Applications." *Gels (Basel, Switzerland)* 2 (1). <https://doi.org/10.3390/gels2010006>.
- Riaz, Ufana, and Syed Marghoob Ashraf. 2014. "Characterization of Polymer Blends with FTIR Spectroscopy." In *Characterization of Polymer Blends*, 625–78. <https://doi.org/https://doi.org/10.1002/9783527645602.ch20>.
- Roy, Ipsita, and Munishwar Nath Gupta. 2003. "Smart Polymeric Materials: Emerging Biochemical Applications." *Chemistry & Biology* 10 (12): 1161–71. <https://doi.org/https://doi.org/10.1016/j.chembiol.2003.12.004>.
- Sawyer, Linda C., David T. Grubb, and Gregorys F. Meyers. 2008. *Polymer Microscopy*. New York: Springer Nature.
- Sun, Shengtong, and Peiyi Wu. 2011. "Infrared Spectroscopic Insight into Hydration Behavior of Poly(N-

Vinylcaprolactam) in Water.” *The Journal of Physical Chemistry B* 115 (40): 11609–18.  
<https://doi.org/10.1021/jp2071056>.

Xie, Rui, Yan Li, and Liang-Yin Chu. 2007. “Preparation of Thermo-Responsive Gating Membranes with Controllable Response Temperature.” *Journal of Membrane Science* 289 (1): 76–85.  
<https://doi.org/https://doi.org/10.1016/j.memsci.2006.11.040>.



## 1,2-PHENYLENE DISTEARYLAMIDE AS A NOVEL PHASE CHANGE MATERIAL FOR THERMAL ENERGY STORAGE

**Nazan Gökşen Tosun**

Dr., Tokat Gaziosmanpaşa University, Tokat Vocational School of Health Services, Department of Medical Services and Techniques, Tokat-Türkiye, (Responsible Author) ORCID: 0000-0001-5269-1067

**Cemil Alkan**

Prof. Dr., Tokat Gaziosmanpaşa University, Faculty of Science and Letter, Department of Chemistry, Tokat-Türkiye, ORCID: 0000-0002-1509-4789

### ABSTRACT

New generation phase change materials for thermal energy storage applications is a hot topic due to the low application potential of the present materials and the benefits from the produced further functionality of new materials. Amine groups in these materials are especially important due to it donated metallic structure to impart energy-harvesting properties to their derivatives. For this reason, 1,2-phenylene distearyl amide has been prepared as a potential material to exploit at around its phase transition temperatures. In this study, 1,2-phenylene distearyl amide has been identified as an original phase change material for thermal energy storage applications. FTIR Spectroscopy analysis was used for characterization. POM was also operated to show the surface morphology difference between the synthesized material and precursor. Thermophysical investigations of 1,2-phenylene distearyl amide have been investigated using DSC analysis and interpreted using the data produced in the tests. As a result, it has been found that the working temperature of the material was also original to be exploited in specific investigations, in spite that it had low phase transformation enthalpy for energy storage applications. Besides, the material is a candidate for its thermal sensor properties.

**Keywords:** phase change material, thermal energy storage, fatty amide.

### Introduction

The increasing need for energy has recently made renewable energy sources more remarkable than existing ones. Thermal energy storage (TES) is an important strategy for effectively using renewable energy resources. Phase change materials (PCMs) are remarkable materials that enable thermal energy to be stored and used when needed. PCMs to be used in TES systems need to be developed to work effectively, functionally, and smoothly. The principle of using PCMs in TES systems is based on the absorption or release of heat, which is a reversible phase change.

Many different materials, such as organic, inorganic compounds, paraffins, and polymeric materials, are being evaluated and developed as PCM. Fatty acids are suitable candidates for systems that provide passive heating, especially with solar energy, because they remain chemically stable for a long time, are non-toxic, and have a suitable melting temperature compared to other PCMs. In addition to their advantages, fatty acids have disadvantages such as corrosive effects, bad odor, and high sublimation rates. Many derivatives of fatty acids have been produced to overcome these disadvantages in the literature by esterification reactions.

In this study, the chemicals stearoyl chloride and 1,2 phenylene diamine were reacted to produce a new PCM, 1,2-phenylene stearyl amide (PDSA). Stearic acid is a PCM known as a fatty acid used to store energy at suitable temperatures. Its various derivatives have been produced before. It is converted to stearoyl chloride to react at low temperatures. 1,2-phenylene diamine is used to have a hard centered molecules, phenylene can crystallize itself. PDSA was synthesized for the first time in this study, and characterized as a new PCM for physicochemical properties thermal energy storage characteristics.

## Materials and Methods

### Materials

#### Synthesis of PDSA

Synthesis of PDSA was performed in a 100 mL polytetrafluoroethylene double-necked valve bottle under nitrogen gas. Slightly more than the stoichiometric amount of 1,2-phenylene diamine was dissolved in toluene at 100 °C, then stearoyl chloride was added at a stoichiometric rate and allowed to react for approximately 4 hours. After the reaction was ended, PDSA was washed with acetone and then ethanol to remove impurities. The scheme of synthesis is given in Figure 1.

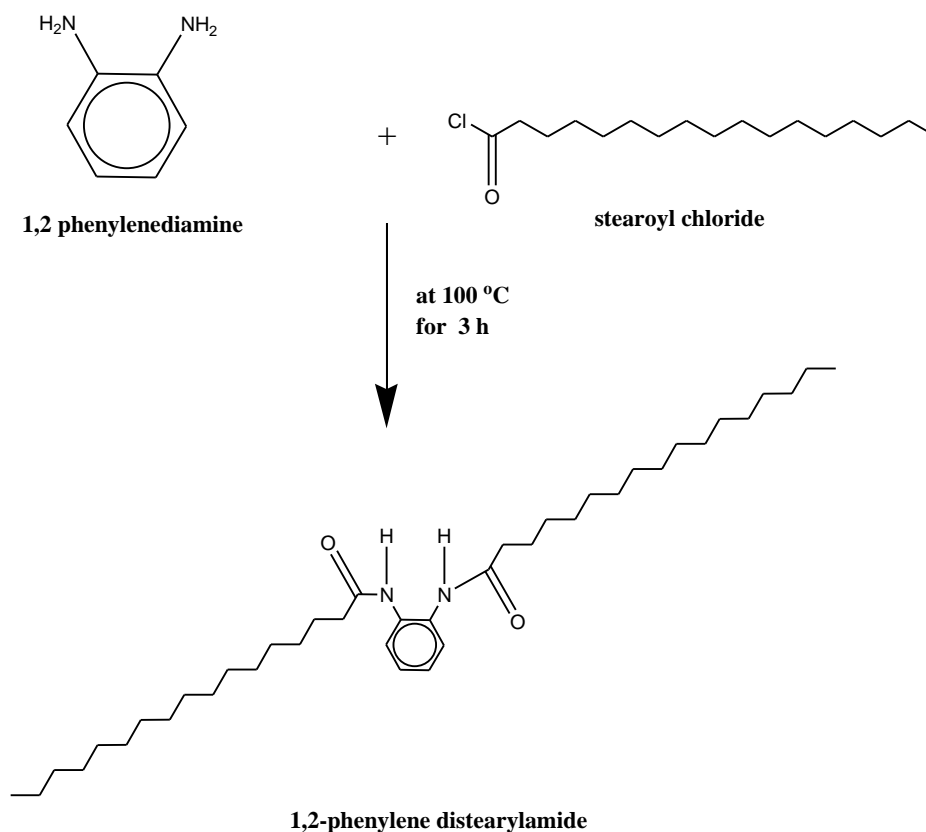

**Figure 1.** The scheme of synthesis PDSA

#### FT-IR Spectroscopy

The chemical characterization of PDSA was performed by FT-IR spectroscopy (instrument model Jasco 430). PDSA was scanned by FT-IR at a wavelength range of 400-4000 cm<sup>-1</sup>.

#### DSC Analysis

Values of thermal properties of PDSA (such as melting and crystallization points) were measured from DSC curves. Calibration of the DSC device (Netzsch DSC214 Polyma) was performed with the indium standard before use. Measurement ranges were set to 30 °C -110 °C as the heating and cooling rates were set at 5 °C min<sup>-1</sup> under an inert nitrogen flow of 60 mL/min.

#### Polarized Optical Microscopy Analyses

Surface crystalline morphologies of 1,2-phenylene diamine and PDSA were observed using Leica polarized optical microscopy DM EP (Germany, 2010).

### Thermal cycling test and thermal stability

The stability analysis was performed to prove the long-term usability of novel energy storage material. The storage properties were determined to evidence consistency. The stability of the synthesized compound PDSA was assayed by heating samples of the material to 110 °C and then cooling them to 30 °C using the BIDER-TC -25/H. The thermal cycling device was programmed to be heated and cooled from 30 °C to 110 °C 1000 times to test the long-term use of PDSA.

### Results and Discussion

FT-IR Spectroscopy method has been used to identify some of organic and inorganic materials' specific groups, and by the way materials, themselves. For this reason, the specific peak positions of expected groups are searched in the spectrum which were obtained by infrared light application and absorption/transition measurements several times. For a synthesized materials, precursors are measured for comparison to the synthesis product which enables the characterization and possible changes in the material structure. Figure 2 in this work is a good example which clearly showed that specific carbonyl group in the precursor stearoyl chloride shifted to 1738  $\text{cm}^{-1}$  from 1784  $\text{cm}^{-1}$ . 1,2-phenylene diamine do not have a carbonyl. Also the persisting  $\text{NH}_2$  groups coming from the 1,2-phenylene diamine turned to NH primer amines not so much characteristic in the produced PDSA. When the other groups from the precursors, except for the ones in the fingerprint region, were searched, they were all found in the spectrum of the synthesized material. Fingerprint region is not considered in general.

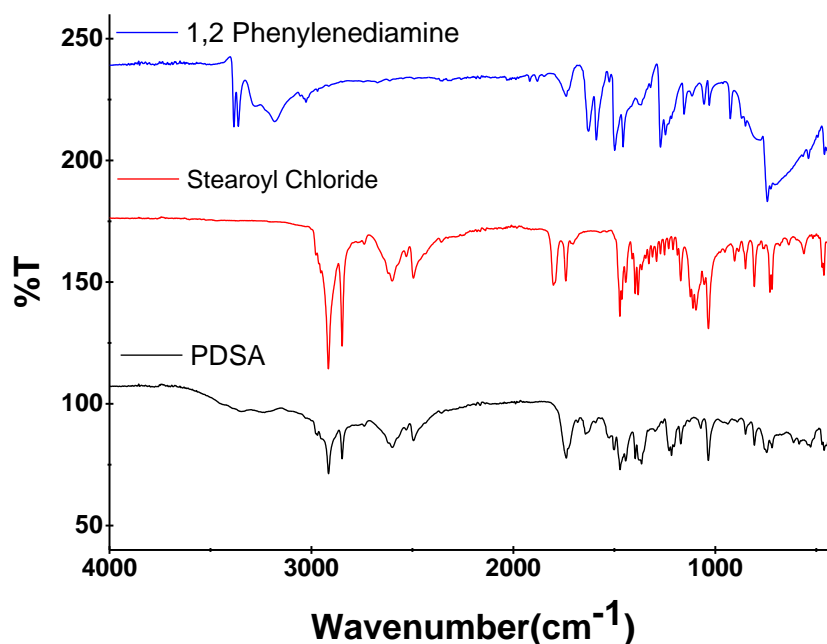
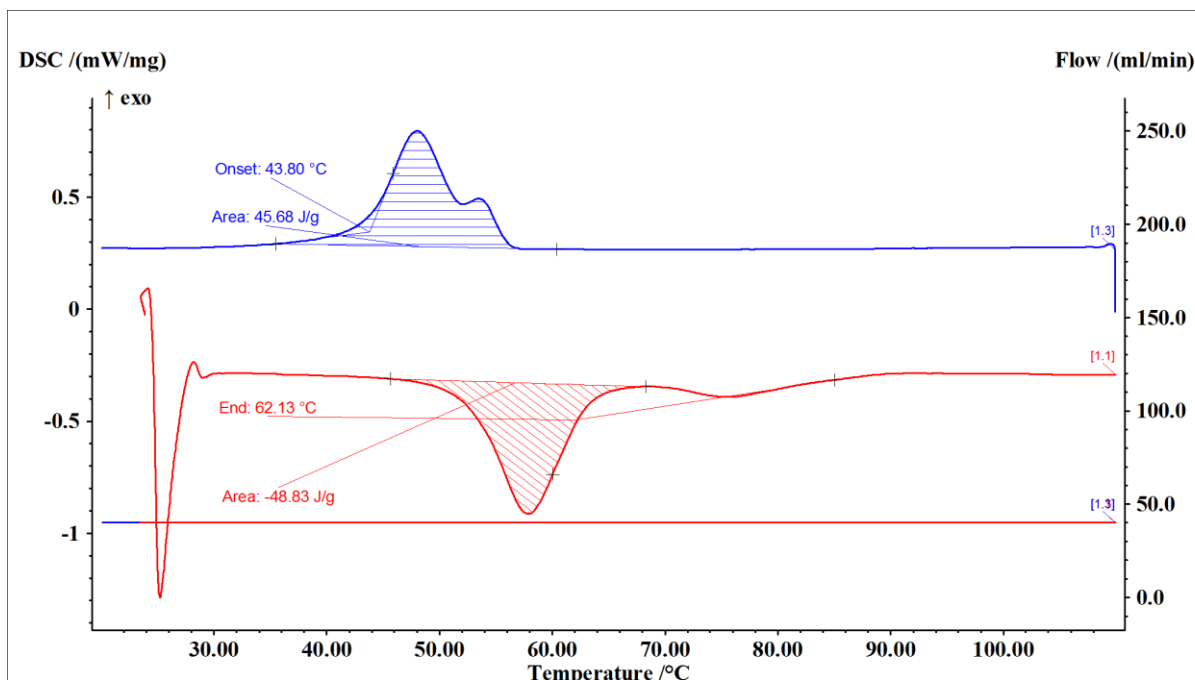

Figure 2. The FT-IR spectra of PDSA

DSC is a technique which is used to determine not only the physical characteristics of the materials but also some application performances like in this study. Figure 3 shows DSC curves during heating (in red color) and cooling (in blue color). The instrument is programmed stepwise and the peaks near the starting points are due to the material response to programming change. The curves include 2 physical changes; former of which is due to solid-solid phase change as the latter one is due to solid-liquid in heating period. In return, during cooling period first peak is due to liquid solid transition as the second one is due to solid-solid phase transition. In spite that the big enthalpy change occurs in solid-solid transitions, these materials should be thought as solid liquid because the phase transition peaks are not well distributed. On the other hand, the enthalpy values are not much for a good exploitation and the materials can then be better used in temperature sensory applications



or additives to thermal energy storage materials to modulate temperature in other materials like paraffins, fatty acids and fatty alcohols.



**Figure 3.** The DSC curve of PDSA

DSC instrument can also be operated to determine temperature dependent specific heat capacity ( $C_p$ ) which is primary indicator of sensible heat storage capacity.  $C_p$  can be determined by programming the DSC instrument in a different way and therefore can be measured and shown only for heating as a single curve (Figure 4). Actually, the value is theoretically the same for the measured material if measured for cooling period.  $C_p$  goes to infinity during phase transformations.  $C_p$  data are listed in Table 1 for below and above the phase transition temperature. The table shows that the  $C_p$  values well before and after phase transitions were considerable, which means that the materials could be successfully exploited in sensible heat storage applications. Total enthalpy curves is another evidence of that the materials could be used as sensible heat storage materials.

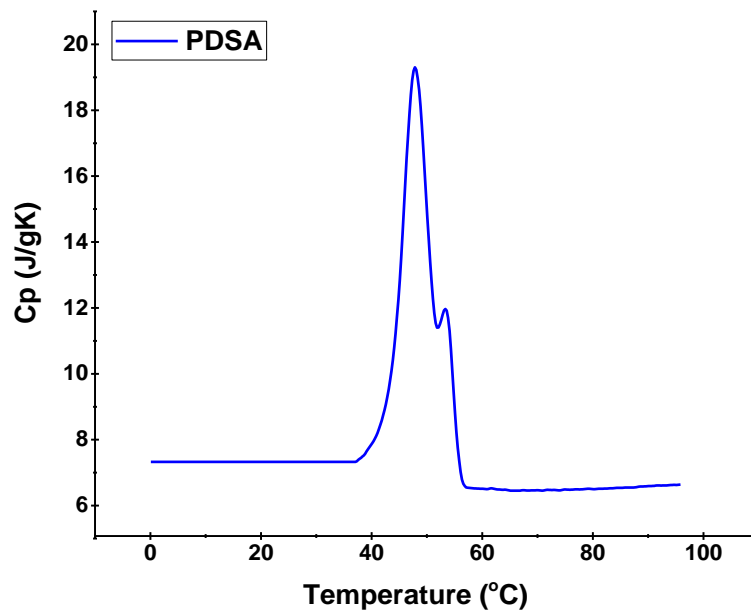
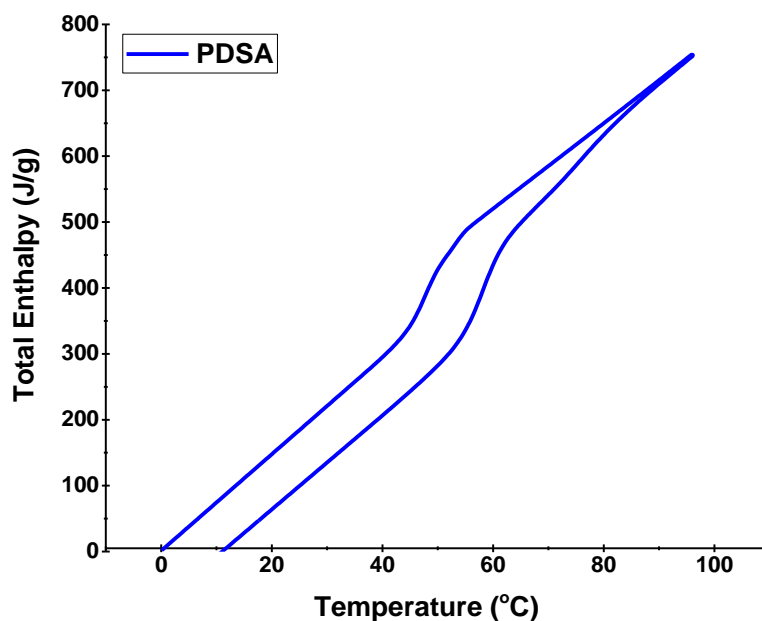

**Figure 4.** The Cp curve of PDSA

**Table 1.** Cp value of PDSA compound

Temperature °C	0	10	20	30	40	50	60	70	80	90	100
<b>Cp(J/g*K)</b>	7.32	7.32	7.32	7.32	7.88	14.74	6.50	6.45	6.49	6.59	6.63

To determine the total amount of stored heat energy, the total enthalpy graphs shown in Figure 5 were drawn using the data obtained from the DSC curves. The energy calculated by taking into account the sum of sensible and latent heat in a certain range determines the total heat energy storage ability of phase change materials.



**Figure 5.** Total enthalpy value of PDSA compound

Small detectable changes in surface micrographs can be evaluated by polarized optical microscopy. In this study, the solid structures of the produced PDSA material and the 1,2-phenylene diamine were compared using a polarized optical microscope. As photographed in Figure 6, it was shown that the crystal surface morphology of PDSA differs from 1,2-phenylenediamine with minor differences, crystalline size of the produced materials much less than 1,2-phenylene diamine.

### 1,2 Phenylene diamine

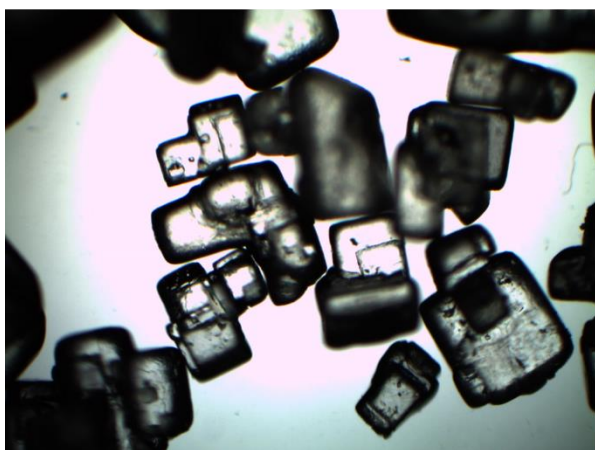

### PDSA

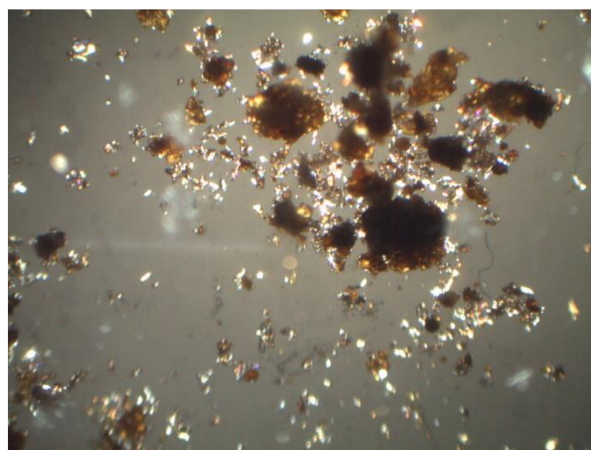

**Figure 6.** POM images of 1,2-phenylene diamine and PDSA

After PDSA was heated and cooled 1000 times with a thermal cycling device, its long-term usability was measured with a DSC instrument. Thermal stability is one of the most important properties of TES material. After repeated 1000 times heated and cooled, melting and crystallization temperatures of PDSA were measured as 49.0 °C and 44.8 °C, respectively.

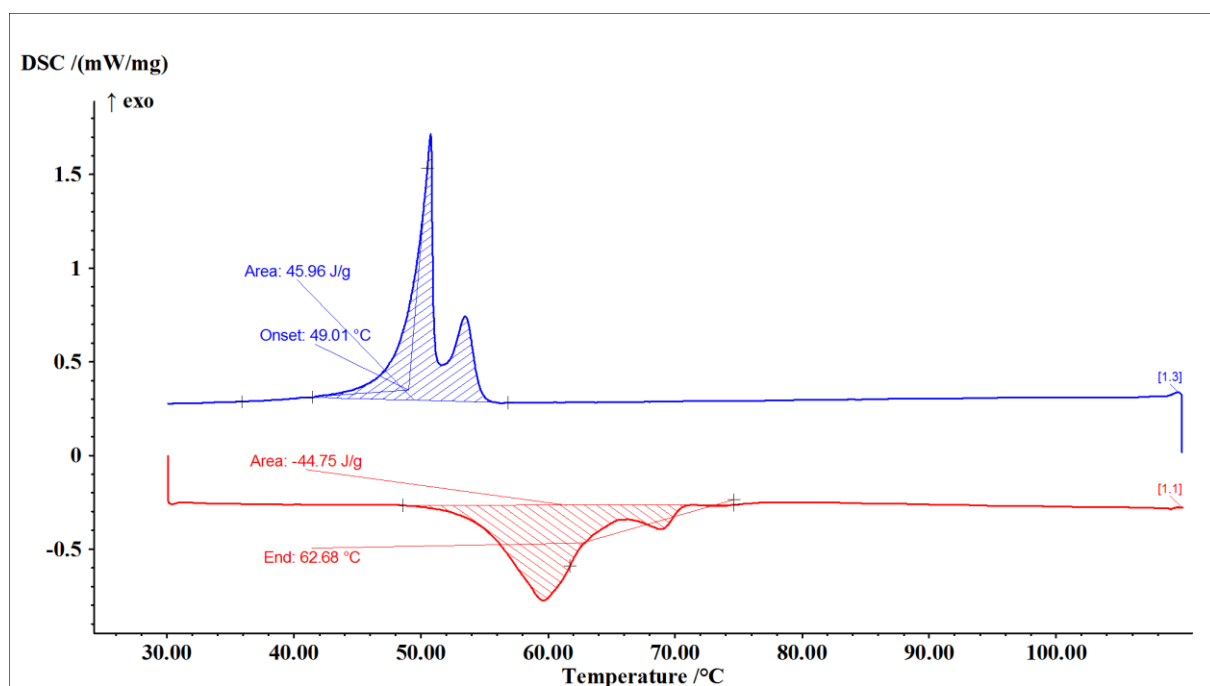

Figure 7. DSC curves of PDSA after thermal cycling process

Table 2. TES characteristics of PDSA in case of thermal cycling operations

Before thermal cycling	First phase transition temperature (Heating period) (°C)	Enthalpy (Heating period) (J/g)	First phase transition temperature (Cooling period) (°C)	Enthalpy (Cooling period) (J/g)
PDSA	53.8	48.8	57.3	-45.7
After thermal cycling	First phase transition temperature (Heating period) (°C)	Enthalpy (Heating period) (J/g)	First phase transition temperature (Cooling period) (°C)	Enthalpy (Cooling period) (J/g)
PDSA	49.0	44.8	62.7	-46.0

At the end of thermal cycling operations, it is clearly seen that the thermal property of the PDSA material is consistent. The only value of first transition temperature during heating is slightly high but at rest the temperature and enthalpy of the values are always regular. The first measurements sometimes slightly high and not dependable due to trace materials present in the system as impurity.

### Conclusion and Recommendations

Derivatives of fatty acids are widely investigated for thermal energy storage due to their potential for new operating temperatures. Since fatty acids may result in corrosion due to acid groups at the end of aliphatic chains.

In this study, PDSA synthesized using stearoyl chloride and 1,2-phenyl diamine was identified, and its capacity to be used as PCM for thermal energy storage was demonstrated. PDSA, a fatty acid derivative, was produced under reaction conditions in high yield and purity. PDSA was analyzed by FTIR spectroscopy in terms of chemical structure, and the success of the synthesis was proven. The new fatty acid derivative synthesized due

to physical characterizations made with DSC and polarized optical microscopy has been revealed as a new PCM candidate for evaluation in solar thermal energy storage areas. Evaluations performed after accelerated heating and cooling cycles for 1000 times have proven its long-term thermal durability.

### References

- [1] B. Zalba, J. Marin, L.F. Cabeza, H. Mehling, Review on thermal energy storage with phase change: materials, heat transfer analysis and applications, *Appl. Therm. Eng.* 23 (2003) 251–283.
- [2] S.D. Sharma, K. Sagara, Latent heat storage materials and systems: a review, *Int. J. Green Energy* 2 (2005) 1–56.
- [3] C. Alkan, Enthalpy of melting and solidification of sulfonated paraffins as phase change materials for thermal energy storage, *Thermochim. Acta* 451 (2006) 126–130.
- [4] Gökşen Tosun, N, Çetin, A, Alkan, C. Novel urea-based compounds as solid-solid phase change materials: 1,3-bisstearylurea and 1,1,3,3-tetrastearylurea for thermal energy storage applications. *Int J Energy Res.* 2022; 46(14): 20600-20610. doi:10.1002/er.7697
- [5] V.V. Tyagi, D. Buddhi, Thermal cycle testing of calcium chloride hexahydrate as a possible PCM for latent heat storage, *Sol. Energy Mater. Sol. Cells* 92 (2008) 891–899.
- [6] K. Pielichowski, K. Flejtuch, Differential scanning calorimetry study of blends of poly(ethylene glycol) with selected fatty acids, *Macromol. Mater. Eng.* 288 (2003) 259–264.
- [7] P. Singh, R.K. Sharma, A.K. Ansu, R. Goyal, A. Sarı, V.V. Tyagi A comprehensive review on development of eutectic organic phase change materials and their composites for low and medium range thermal energy storage applications, *Solar Energy Materials and Solar Cells*, 223, 2021, 110955, <https://doi.org/10.1016/j.solmat.2020.110955>.
- [8] W.D. Li, E.Y. Ding, Preparation and characterization of cross-linking PEG/MDI/ PE copolymer as solid–solid phase change heat storage material, *Sol. Energy Mater. Sol. Cells* 91 (2007) 764–768.
- [9] K. Pielichowski, K. Flejtuch, Recent developments in polymeric phase change materials for energy storage: poly(ethylene oxide)/stearic acid blends, *Polym. Adv. Technol.* 16 (2005) 127–132.
- [10] Alkan, C., Gökşen Tosun, N. and Kaplan, Ö. (2023), Synthesis and Characterization of Dicarboxylic Acid Esters of 1-Hexadecanol for a Thermal Energy Storage Application Range of 50–55 °C. *Energy Technol.*, 11: 2300104. <https://doi.org/10.1002/ente.202300104>.
- [11] D. Feldman, D. Banu, D.W. Hawes, Development and application of organic phase change mixtures in thermal storage gypsum wallboard, *Sol. Energy Mater. Sol. Cells* 36 (1995) 147–157.
- [12] Z. Zhang, X. Fang, Study on paraffin/expanded graphite composite phase change thermal energy storage material, *Energy Convers. Manage.* 47 (3) (2006) 303–310.
- [13] D. Rozana, T.G. Chuah, A. Salmiah, Thomas S.Y. Choong, M. Sa'ari, Fatty acids as phase change materials (PCMs) for thermal energy storage: a review, *Int. J. Green Energy* 1 (4) (2005) 495–513.
- [14] W. Li, E. Ding, Preparation and characterization of a series of diol di-stearates as phase change heat storage materials, *Mater. Lett.* 61 (7) (2007) 4325–4328.
- [15] W. Li, E. Ding, Preparation and characterization of a novel solid–liquid PCM: Butanediol di-stearate, *Mater. Lett.* 61 (2007) 1526–1528.
- [16] C. Alkan, K. Kaya, A. Sarı, Preparation and thermal properties of ethylene glycole distearate as a novel phase change material for energy storage, *Mater. Lett.* 62 (2008) 1122–1125.
- [17] G. Canik, C. Alkan, Hexamethylene dilauroyl, dimyristoyl, and dipalmytoyl amides as phase change materials for thermal energy storage, *Sol. Energy* 84 (2010) 666–672.
- [18] D. Feldman, D. Banu, D. Hawes, Low chain esters of stearic acid as phase change materials for thermal energy storage in buildings, *Sol. Energy Mater. Sol. Cells.* 36 (1995) 311–322.

[19] P.E. Arndt, J.G. Dunn, R.L.S. Willix, Organic compounds as candidate phase change materials in thermal energy storage, *Thermochim. Acta* 79 (1984) 55–68.



## EFFECT OF FINANCIAL INCENTIVE POLICIES ON RENEWABLE ELECTRIC ENERGY PRODUCTION: AN EVALUATION FROM TURKIYE'S PERSPECTIVE

**Mehmet TUNÇER**

Prof. Dr., Karadeniz Technical University, Faculty of Economics and Administrative Sciences, Department of Public Finance, Trabzon-Türkiye, (Responsible Author) ORCID: 0000-0002-7158-5398

**Hasret KAYA**

Research Assistant, Karadeniz Technical University, Faculty of Economics and Administrative Sciences, Department of Public Finance, Trabzon-Türkiye, ORCID: 0000-0001-9896-9204

### ABSTRACT

Climate change is one of the serious environmental problems in the contemporary world that needs to be resolved as soon as possible. In order to combat climate change, first of all, carbon emissions, which have the largest share in the occurrence of climate change, must be minimized. In order to accomplish this, it is necessary to abandon the use of fossil resources, which cause carbon emissions, and to use new, domestic and renewable resources. Renewable energy sources consist of sources that, unlike fossil fuels obtained from natural sources, are not likely to be exhausted in the near future and do not cause carbon emissions or emit very little carbon. Incentive policies implemented by the states play an important role in expanding the use of renewable energy resources. In the study, Sweden, Norway, Brazil, Spain and Canada, which have been following a stable trend for the last ten years and rank first in the world, were examined in order to have an idea about the effect of financial incentive policies, which have an important place in the fight against environmental problems, applied to promote renewable energy sources on renewable energy. In addition, the financial incentive policies of aforementioned countries and the policies implemented by Turkey will be compared and the circumstance of financial incentive policies of Turkey will be assessed, and some suggestions will be tried to make in order to resolve the shortcomings of Turkey's policies.

**Keywords:** Renewable Energy, Incentive Policies, Financial Incentive Policies, Energy Policies

### YENİLENEBİLİR ELEKTRİK ENERJİSİ ÜRETİMİNDE MALİ TEŞVİK POLİTİKALARININ ETKİSİ: TÜRKİYE AÇISINDAN BİR DEĞERLENDİRME

### ÖZET

İklim değişikliği, günümüzde hızlı bir şekilde çözüme kavuşturulması gereken ciddi bir çevre sorunudur. İklim değişikliğiyle mücadele edebilmek için öncelikle iklim değişikliğinin oluşmasında en büyük paya sahip olan karbon emisyonunun en aza indirilmesi gerekmektedir. Bunun için, karbon emisyonuna neden olan özellikle fosil kaynakların kullanımından vazgeçilerek yeni, yerli ve yenilenebilir kaynakların kullanılması gerekmektedir. Yenilenebilir enerji kaynakları, doğal kaynaklardan elde edilen fosil yakıtların aksine yakın gelecekte tükenme ihtimali olmayan ve karbon emisyonuna neden olmayan veya çok az miktarda karbon salan kaynaklardan oluşmaktadır. Yenilenebilir enerji kaynaklarının kullanımının yaygınlaştırılmasında devletler tarafından uygulanan teşvik politikaları önemli bir rol oynamaktadır. Bu bağlamda çalışmada, çevre sorunlarıyla mücadele konusunda önemli bir yere sahip olan yenilenebilir enerji kaynaklarını teşvik etmek üzere uygulanan mali teşvik politikalarının yenilenebilir enerji üzerindeki etkisi hakkında fikir sahibi olabilmek adına yenilenebilir enerji kaynaklarından elektrik enerjisi kullanımında son on yıldır istikrarlı bir trend izleyen ve dünya sıralamasında ilk sıralarda yer alan İsveç, Norveç, Brezilya, İspanya ve Kanada'ya yer verilmiştir. Ayrıca sayılan ülkelerin mali teşvik politikaları ile Türkiye'de uygulanan mali teşvik politikaları karşılaştırılarak Türkiye'de uygulanan mali teşvik politikalarının durumu tartışılarak mali teşvik politikalarının eksik yönlerine ilişkin öneride bulunulmaya çalışılacaktır.

**Anahtar Sözcükler:** Yenilenebilir Enerji, Teşvik Politikaları, Mali Teşvik Politikaları, Enerji Politikaları

## Giriş

Sanayileşme olgusunun gelişmesiyle birlikte üretim süreci yapısal bir dönüşüme uğramıştır. Üretim sürecinde daha fazla enerjiye ihtiyaç duyulurken kullanılan enerji kaynaklarının yapısı itibarıyla çevre kirliliğinde artış yaşanmıştır. Üretimde kömür, petrol ve doğalgaz gibi fosil kaynakların kullanımı oldukça yaygınlaşmıştır. Öte yandan sanayileşmiş ve sanayileşmekte olan ülkelerde yaşanan hızlı ekonomik büyüme kentleşmeyi hızlandırmıştır. Hızla büyüyen kentleşmeyle birlikte kent yaşamında enerji üretimi, ısıtma, soğutma ve pişirme gibi amaçlarla fosil kaynakların kullanımı artmıştır. Fosil kaynakların kullanılmasıyla başta karbondioksit olmak üzere birçok zararlı gaz çevreye salınmaktadır. Zararlı gazların oluşturduğu çevre kirliliği ise küresel ısınmaya, dolayısıyla iklim değişikliğine neden olmaktadır. İklim değişikliği, tüm dünyayı ilgilendiren ve süratle çözüm üretilmesi gereken küresel bir çevre problemidir. 1992 yılında, iklim değişikliği ile mücadele etmek için oluşturulan küresel politikaları desteklemek üzere Birleşmiş Milletler İklim Değişikliği Çerçeve Sözleşmesi imzalanmıştır. Ardından 1997 yılında, Kyoto Protokolü sera gazı emisyonlarını ulusal hedeflere uygun olarak azaltmak veya sınırlandırmak üzere kabul edilmiş ve 2015 yılında, küresel sera gazı emisyonlarını önemli ölçüde azaltmak üzere Paris Anlaşması imzalanmıştır. İklim değişikliğiyle mücadele etmek üzere imzalanan bu protokol ve anlaşmalar, sera gazı emisyonlarının azaltılmasına yönelik hedefler belirlemiştir. Sera gazı emisyonlarını azaltmanın en etkili yolu emisyonuna neden olan kaynak kullanımının azaltılmasıdır. Üretim ve tüketimde kömür, petrol ve doğalgaz gibi fosil enerji kaynaklarının kullanımını azaltıp yerine güneş, rüzgâr, jeotermal, hidroenerji, biyoenerji ve deniz enerjisi gibi yenilenebilir enerji kaynakları kullanılarak sera gazı emisyonları azaltılabilmektedir.

Yenilenebilir enerji kaynakları, kullanım esnasında çevreye herhangi bir sera gazı yaymayan doğal kaynaklardan sürekli olarak sağlanan temiz enerji kaynaklarıdır. Yenilenebilir enerji kaynaklarının önemli özelliklerinden bir tanesi yakın gelecekte tükenmesi muhtemel olan fosil yakıtların aksine kendini sürekli yenileyebilen, gelecekte tükenme ihtimali çok az olan, sürdürülebilir kaynaklar olmasıdır.

İklim değişikliğiyle mücadelede önemli bir role sahip olmasına rağmen yenilenebilir enerji kaynaklarının, ekonomik nedenlerle toplam enerji üretimindeki payı halen istenilen seviyede değildir. Özellikle yenilenebilir enerji üretim sürecinde kullanılan teknik malzemelerin pahalı olması nedeniyle ilk kurulum maliyetlerinin yüksek olması yatırımcıları caydırabilmektedir. Yenilenebilir enerji üretiminin cazip hale getirilmesinde devletlere önemli görevler düşmektedir. Buna göre devletler, yenilenebilir enerji kurumlarına ilişkin bürokratik süreçleri kolaylaştırarak enerji üretimini hızlandırabileceği gibi mali teşvikler sağlayarak da yatırımcıları yenilenebilir enerji yatırımlarına çekebilir. Mali teşvikler, yenilenebilir enerjiye ait kurulum ve üretim maliyetlerini yatırımcılar açısından katlanılabilir bir seviyeye çekmek için, maliyetlerin bir kısmının hükümetler tarafından yüklenilmesi ya da kurulum ve üretim sürecinin tamamen hükümetler tarafından gerçekleştirilmesiyle uygulanabilir. Ayrıca devletler, fosil kaynakları vergiler yoluyla daha maliyetli hale getirerek yenilenebilir enerji kaynaklarını fosil kaynaklar karşısında alternatif olarak tercih edilir hale getirebilir.

Çalışmada, yenilenebilir enerji kullanımının yaygınlaştırılmasında önemli bir yere sahip olan mali teşvik politikaları yenilenebilir enerji üretim seviyelerine bakılarak seçilmiş bazı ülkelere ait veriler ışığında irdelenmektedir. Bu doğrultuda öncelikle mali teşvik uygulamalarının neler olduğundan bahsedilecektir. Ardından çalışmada yenilenebilir enerji üretimleri ile uyguladıkları mali teşvik politikalarına ilişkin verilerinden yararlanan ülkelere bahsedilerek mali teşvik politikaları ile yenilenebilir enerji üretimi arasındaki ilişki tartışılacak ve konuya ilişkin öneride bulunulacaktır.

## 1. Elektrik Üretiminde Yenilenebilir Enerji Kaynaklarının Kullanımına Yönelik Mali Teşvikler

Günümüzde ciddi boyutlara ulaşmış olan iklim değişikliği, kamu politikaları yardımıyla çözülmesi gereken önemli bir sorundur. İklim değişikliğiyle mücadelede, iklim değişikliğinin birincil sorumlusu olan temiz olmayan enerji kullanımının azaltılarak, temiz, yeni ve yenilenebilir enerji kaynaklarının yaygınlaştırılması ve kullanımının teşvik edilmesi de kamu politikasının görevlerindedir. Bu bağlamda yenilenebilir enerji politikasına değinmek gerekirse, yenilenebilir enerji politikalarının amacı temel olarak yenilenebilir enerjinin geliştirilmesi, yaygınlaştırılması ve yenilenebilir olmayan diğer enerji kaynaklarıyla rekabet edebilir hale getirilmesidir. Bu politikalar yenilenebilir enerjinin üretimi, tüketimi ve geliştirilmesi gibi uygulamaları düzenlemek için gereken kanun ve kuralların uygulanmasının yanı sıra yenilenebilir enerji üretimini ve



tüketimini artırmayı hedefleyen teşvik politikalarını da içermektedir. Teşvik politikaları literatürdeki en yaygın kullanım şekliyle bir bütün olarak Tablo 1’de gösterilmektedir.

**Tablo 1: Yenilenebilir Enerjiye Yönelik Teşvik Politikaları**

Düzenleyici Politikalar	Mali Teşvikler
Tarife Garantisi (Sabit Fiyat Garantisi ve Prim Garantisi)	Vergi Muafiyetleri ve İstisnaları
Kota Yükümlülüğü (Yenilenebilir Portföy Standardı)	Vergi Kredileri (Yatırım Vergisi Kredisi ve Üretim Vergisi Kredisi)
İhale Yöntemi	Karbon Fiyatlandırması
Net Ölçüm Sistemi	Kamu Yatırımları, Krediler, Hibeler, Sermaye Sübvansiyonları veya İndirimleri
Biyoyakıt Kullanma Yükümlülüğü	
Yenilenebilir Isı Yükümlülüğü	

**Kaynak:** REN21, 2022

Çalışma sadece mali teşvik politikalarına yönelik olduğundan aşağıda mali teşvikler kısaca açıklanmaktadır. Mali teşvikler birçok ülke tarafından, belirli sektörlerdeki yatırımları artırmak için yatırımların kârlılık seviyesini yükseltme aracı olarak kullanılmaktadır. Enerji geçişini desteklemek için mali araçlar, fosil kaynaklı enerjiye ya da nükleer enerjiye ek bir vergi yükü yükleyerek ve karşılığında yenilenebilir enerji kaynaklarına vergi teşvikleri uygulayarak kullanılmaktadır. Böylelikle yenilenebilir enerji lehine bir kârlılık avantajı sağlamak amaçlanır (Büsching vd., 2020). Mali teşvikler; vergi yükünden muafiyet ve istisna, kamu yatırımları, krediler, hibeler ya da fosil veya nükleer kaynaklara ek vergi yükü yüklenerek negatif çevresel dışsallıkların fiyatlandırılması şeklinde uygulanabilmektedir.

Vergi muafiyeti ve istisnası dünyanın birçok yerinde yenilenebilir enerji üretimini artırmak için bir mali teşvik türü olarak uygulanmaktadır. Vergilendirilmesi gereken bir vergi ödeme gücünün varlığı durumunda mükellefler ile vergi konularının, vergi yasaları karşısında adil bir şekilde vergilendirilmeleri bakımından vergi kapsamına alınması gerekmektedir. Ancak sosyal, kültürel, ekonomik, mali ve idari nedenlerle bazı kişi ya da kişi grupları ile bir kısım vergi konularının vergilendirilmemesi yoluna gidilmektedir. Vergi kanunlarına göre vergilendirilmesi gereken kişi ya da kişi gruplarının aynı veya başka kanunlarla vergi dışı bırakılmasına vergi muafiyeti denilmektedir. Vergi istisnası ise vergi kanunlarına göre vergilendirilmesi gereken vergi konularının aynı veya başka kanunlarla kısmen ya da tamamen vergi dışı bırakılmasıdır (Akdoğan, 2011:156). Yenilenebilir kaynaklardan enerji üretimini artırmak için çeşitli ülkelerde gelir vergisi, kurumlar vergisi, katma değer vergisi, özel tüketim vergisi ve emlak vergisi üzerinde vergi muafiyeti ve istisnası uygulamaları mevcuttur. Vergi muafiyeti ve istisnası yenilenebilir enerjinin üretim, dağıtım ve tüketim gibi farklı aşamalarında uygulanabilir. Örneğin, yenilenebilir enerji kaynaklarından üretilen elektriğin yatırım, üretim veya tüketim bölümleri için vergi indirimi uygulanabilir. Yenilenebilir enerji tüketimini teşvik etmeyi amaçlayan politikalar, yenilenebilir enerji dağıtımının piyasaya girmesini kolaylaştırmak için yenilenebilir ekipmanın satın alınması ve kurulumuna vergi kredileri uygulayabilmektedir (Abolhosseini ve Heshmati, 2014:880).

Yenilenebilir kaynaklara uygulanan bir diğer teşvik yöntemi hızlandırılmış amortismandır. Hızlandırılmış amortisman, firmaların yatırımlarını aktif ettikleri dönemden itibaren yüksek kârlılıklar oluşması durumunda normal amortisman yöntemine göre daha fazla amortisman gideri yazılmasını sağlayarak firmalara vergi avantajı getirmektedir. Böylelikle bahsi geçen dönem için daha az vergi ödendiğinden nakit akışına pozitif katkı sağlanmış olmaktadır (Şen ve Sağbaş, 2016:400). Hızlandırılmış amortisman, vergilendirilebilir geliri ve dolayısıyla vergi yükümlülüğünü azaltarak proje sahibine fayda sağlarken, vergilerin yükseldiği sonraki yıllarda, hükümetin sübvansiyonun bir kısmını geri almasını sağlamaktadır (Shrimali vd., 2017:546).

Vergi kredileri, genellikle ekonomiye ya da çevreye faydalı olduğu düşünülen belirli eylemleri teşvik etmek, ödüllendirmek ya da hükümet tarafından faydalı görülen bu eylemlerin devamlılığını sağlamak üzere tasarlanmıştır. Vergi kredisinin esas çalışma prensibi vergi mükellefinin ödeyeceği vergi miktarını

azaltmasıdır. Uygulamaya yenilenebilir enerji açısından bakılacak olursa vergi kredileri, bireylerin ve işletmelerin yenilenebilir enerji kaynaklarını kullanması için maliyetlerin azalmasına yardımcı olan devlet destekli bir teşviktir (Liberto, 2022). Birçok ülkede yenilenebilir enerji kaynaklarından üretilen elektriğin yatırım, üretim veya tüketim bölümleri için vergi kredisi uygulanmaktadır. Yenilenebilir enerjiyi teşvik eden politikalar, yenilenebilir enerji üretiminin enerji piyasasına kolayca girebilmesini sağlamak için yenilenebilir santral kurulumu ve ekipman satın alınması aşamalarına vergi kredileri uygulayabilmektedir (Abolhosseini ve Heshmati, 2014:880).

Vergi kredileri, yatırım vergisi kredileri ve üretim vergisi kredileri olarak iki şekilde uygulanmaktadır. Yatırım vergisi kredisi, yenilenebilir enerjiye yapılan yatırımların, bir proje geliştiricisinin, endüstrinin, bina sahibinin vergi yükümlülüklerine veya gelirlerine karşı tamamen veya kısmen kredilendirilmesine izin veren bir mali teşviktir. Üretim vergisi kredisi, nitelikli bir mülkün veya tesisin yatırımcısına veya sahibine, o tesis tarafından üretilen yenilenebilir enerji (elektrik, ısı veya biyoyakıt) miktarına dayalı bir vergi kredisi sağlayan bir mali teşviktir (Doran, 2023). Yatırım vergisi kredisi, yenilenebilir enerji yatırımcılarının büyük miktarlardaki ilk kurulum maliyetleriyle baş edebilmesi için uygulanmaktayken, üretim vergisi kredisi enerji üretimini ödüllendirerek işletme performansını teşvik etmeyi amaçlamaktadır (Beck ve Martinot, 2004:11).

Vergi kredilerinin bir diğer uygulaması gelir vergisi kredisidir. Bu uygulama, uygun yenilenebilir enerji sistemlerinin ve yenilenebilir yakıtların satın alınması ya da dönüştürülmesi için kullanılmaktadır (Beck ve Martinot, 2004:11). Ülkelerin nihai enerji kullanımı ve sera gazı emisyonlarında konut ve işyeri gibi binaların ağırlığı göz önüne alındığında, mevcut binalarda enerji verimliliğini sağlayacak girişimlerin teşvik edilmesi enerji politikasının önemli bir parçasıdır. Bu amaçla, bireyleri binaların enerji verimli şekilde dönüştürmesi için yatırım yaptırmak üzere birçok ülke gelir vergisi kredileri kullanmaktadır.

Karbon fiyatlandırması, fosil enerji kullanımını azaltmak ve daha temiz yakıt kullanımına geçmek için kapsamlı teşvikler sunmaktadır. Karbon fiyatlandırması, fosil yakıtların karbon içeriğine veya karbon emisyonlarına uygulanan bir karbon vergisi şeklinde olabileceği gibi emisyon ticareti şeklinde de uygulanabilmektedir (Parry vd., 2021:10). Karbon vergisi, karbon bazlı yakıtların yakılması üzerine uygulanan bir ücrettir. Yüksek karbonlu yakıtların ekonomi genelinde kullanımını azaltmak ve çevreyi aşırı karbondioksit emisyonlarının zararlı etkilerinden korumak için bir teşvik olarak kullanılmaktadır. Kömür, petrol ve doğalgaz gibi fosil yakıtlar yakıldığında karbondioksit salarak iklim değişikliğine neden olur. Firmalar, karbondioksit emisyonları yoluyla çevreye verdiği zararlar nedeniyle toplum üzerinde maliyet olarak adlandırılan negatif bir dışsallık üretmiş olur. İşte karbon vergisi de firmaların neden olduğu bu maliyeti içselleştirmenin bir yolu olarak görülmektedir. Firmalar, karbon vergisi yoluyla neden oldukları maliyetin bir kısmını ödemek zorunda bırakılarak karbon salımına neden olan üretim şekline caydırılmaya çalışılır (Sarigül ve Topçu, 2021:44). Emisyon ticareti, firmaların belirli bir miktarda karbondioksit veya diğer sera gazlarını salmasına izin veren kredilerin alım satımı şeklinde tanımlanabilir. Emisyon ticaretinde, emisyonlar için bir üst tavan belirlenmekte ve bu tavan miktarını geçene önceden belirlenen caydırıcı bir ceza uygulanmaktadır. Emisyon ticareti uygulaması, kirliliği azaltmak için belirli önlemleri zorunlu kılmak yerine, emisyonlarını azaltan firmaları ödüllendirip, azaltmayanlara mali yükler yüklemektedir (Schmalensee ve Stavins, 2017:3).

Emisyon ticareti ile karbon vergisi arasındaki temel fark emisyonun fiyatından ve toplam emisyon azaltım miktarından kaynaklanmaktadır. Toplam emisyon azaltım miktarı emisyon ticareti uygulaması ile önceden belirlenirken emisyon fiyatı belirlenemez. Aksine, emisyon fiyatı karbon vergisiyle önceden belirlenirken toplam emisyon azaltım miktarı önceden belirlenemez. Emisyon ticareti uygulamasıyla, karbon emisyonları üzerindeki üst sınır keskin bir şekilde belirlenmekte, kullanılmayan krediler diğer firmalarla takas edilebilmekte ve firmalar daha yeşil teknolojilere yatırım yapılması konusunda teşvik edilmektedir. Karbon vergileri ise bir yandan hükümetlere temiz enerji geliştirebilmeleri için gelir sağlarken bir yandan da sosyal, ekonomik ve çevresel faydalar sağlamaktadır. Ayrıca karbon vergileri farklı fosil yakıtlarına farklı oranlarda uygulanabilme açısından da avantaj sağlamaktadır (Smoot, 2022).

Öte yandan kamu sektörü, politika önlemleri ve programları aracılığıyla yenilenebilir enerjiye yatırım yapılması için elverişli bir ortamın oluşturulmasında kritik bir rol oynamaktadır. Kamu sektörünün bu yönde uyguladığı politikalar, yenilenebilir projelerin risk-getiri profillerini iyileştirerek sektörü özel yatırımcılar için cazip hale getirebilir. Hükümetler, özellikle çok taraflı ve iki taraflı kalkınma finansmanı kurumları, ulusal fonlar ve yeşil yatırım bankaları gibi diğer ulusal finans kurumları aracılığıyla kamu fonlarını yenilenebilir enerji kaynaklarına aktararak özel yatırımları harekete geçirebilir. Kamu kesimine ait finans mekanizmalarının

yenilenebilir projelere yatırım yapmasıyla, yenilenebilir enerji sektörüne ve nispeten yeni teknolojilere ilk finansmanın enjekte edilmesine, özel kesim sermaye sağlayıcılarıyla karma finans işlemlerine girilmesine, özel yatırımcıların güvenini artırmak için yatırım risklerinin üstlenilmesine ve finansman maliyetlerinin düşürülmesine katkı sağlanmış olur (Irena.org, 2023).

Kamu kesimi doğrudan yenilenebilir projelere yatırım yapılması dışında krediler ve hibeler yoluyla da yenilenebilir enerji teknolojilerinin geliştirilmesini ve yayılmasını desteklemektedir. Hibeler genellikle, bir yenilenebilir enerji projesinin rekabet gücünü artırarak, üreticilere üretilen enerjiyi satın alma garantisi verebilmek ya da nihai tüketicilerin katlanacağı fiyatları düşürebilmek için proje yatırım maliyetlerinin bir kısmını finanse ederler. Koşulsuz şekilde verilen hibeler, projenin kendisi üzerinde herhangi bir kontrol gücüne sahip olmadığından proje yatırımcısını uygulanabilir bir proje sunmaya teşvik etmese de bir projenin maliyetlerini karşılanabilecek seviyeye indirebilecek finansman yollarından birisi olarak görülmektedir. Hibeler, uygulama ve yönetilme bakımından basit olması nedeniyle avantaj sağlamaktadır. Ancak, hibe verilen projelerin, proje hedeflerini karşılayabilecek şekilde tasarlanıp tasarlanmadığının kontrol edilememesi bakımından dezavantajlıdır. Hibeler genellikle verilirken, belirlenen hedefe ulaşılması koşuluyla geri ödenmez. Bazı durumlarda, hibe verilen proje ticari başarıya ulaştığında, hibeler krediye ya da öz sermayeye dönüştürülebilir (Kalamova vd., 2011:14). Kredi ve özsermaye arasındaki temel fark bu iki finansman yönteminin hangi yenilenebilir projede kullanıldığıyla ilgilidir. Krediler genellikle alışlagelmiş ve daha önceden denenmiş teknolojilere sahip projelere uygulanırken, özsermaye, daha çok yeni ve yenilikçi teknolojilere sahip projelere uygulanmaktadır. Finansman krediler yoluyla gerçekleştiğinde, bankalar proje çıktısı yerine borcun geri ödenmesine odaklandığından proje getirisi diğer finansman yöntemlerine göre daha az olmaktadır (Donastorg vd., 2017:4).

Ayrıca, yenilenebilir enerji santrallerine ait maliyetlerin büyük kısmını ilk yatırım maliyetleri oluşturmaktadır. Proje yatırımcıları, bu ilk yatırım maliyetlerini finanse edebilmek için sermaye sübvansiyonlarından faydalanmaktadırlar. Sermaye sübvansiyonu, bir projenin peşin sermaye maliyetini kapsayan bir sübvansiyondur. Bir devlet kurumu ya da devlet bankası tarafından yapılan tek seferlik ödemeler, indirimler ve tüketici hibeleri sermaye sübvansiyonlarına örnek verilebilir (REN21, 2022:230).

## 2. Seçilmiş Ülkelerde Elektrik Üretiminde Yenilenebilir Enerji Kaynaklarının Kullanımına Yönelik Mali Teşvikler

Yenilenebilir enerji kaynaklarının küresel enerji karışımındaki payı 2010'dan bu yana %10 artarak neredeyse %30'a yükselmiştir. Bu artış bir yandan üretilen elektriğin 2/3'ünün karşılandığı büyük hidroelektrik kaynaklara sahip ülkelere kaynaklanırken diğer yandan iddialı yenilenebilir enerji politikaları sayesinde güneş ve rüzgâr teknolojilerinin elektrik üretim maliyetlerini düşürerek, enerji karışımında yenilenebilir enerjinin payını önemli ölçüde artıran ülkelere kaynaklanmaktadır. Son 10 yıllık süreçte bu artış düzenli olarak belli başlı ülkelere sağlanmaktadır. Tablo 2'de yenilenebilir enerjinin küresel elektrik enerjisi karışımındaki payının artmasına katkısı olan ilk sıradaki ülkelere bazılarının yer verilmiştir.

**Tablo 2:** Yenilenebilir Enerji Kaynaklarının Küresel Elektrik Enerjisi Karışımındaki Payı 2013-2022 Dönemi (%)

	2013	2014	2015	2016	2017	2018	2019	2020	2021	2022
<b>Norveç</b>	97,7	97,7	97,7	97,8	97,8	97,8	97,7	98,4	99,1	98,5
<b>Brezilya</b>	76,8	73,3	74,1	80,5	79,2	82,4	82,3	84,2	77,4	89,2
<b>İsveç</b>	54,1	55,9	63,3	57,2	57,9	55,8	58,7	68,5	67,4	68,5
<b>Kanada</b>	64,1	63,3	64	64,9	66,6	66	65,9	67,1	67,1	68,8
<b>İspanya</b>	40,5	40,9	35,7	39,3	32,9	38,8	37,8	44,5	47	43,1
<b>Türkiye</b>	28,8	20,9	32	32,9	29,3	32,1	43,5	41,8	35,4	41,9

**Kaynak:** Enerdata

Tablo 2’de ele alınan ülkeler genel itibariyle yenilenebilir enerji kaynaklarından elektrik enerjisi kullanımında istikrarlı bir trend izlemekte ve dünya sıralamasında ilk sıralarda yer almaktadırlar. Seçilen ülkelerin yenilenebilir kaynaklardan elektrik üretimine ilişkin mali teşvik politikası kısaca aşağıdaki gibidir.

Norveç, Avrupa’nın kuzeyinde yer alan, 384.486 km<sup>2</sup> yüzölçümüne sahip bir İskandinav ülkesidir. Güneybatı ve orta kesimlerinde geniş plato bölgeleri olmakla beraber dağlık bir arazi yapısına sahiptir. Yüksek drenajlı nehirleri ve 65.000 gölünün yaklaşık 1.650’sinin deniz seviyesinden 500 m yüksekte yer alması sayesinde muazzam bir hidroelektrik potansiyeline sahiptir (Christensen, 2022). Norveç, Avrupa nüfusunun yalnızca %1’ine sahip olmasına karşılık Avrupa’daki hidroelektrik kaynaklarının %20’sine, su rezervlerinin %50’sine (hidroelektrik üretimi için depolanan su), doğalgaz kaynaklarının %40’ına ve petrol kaynaklarının %60’ına sahiptir. Elektrik üretiminin %95’i ülke geneline yayılmış 1600 hidroelektrik santralinden, %3,5’i ise rüzgâr enerjisinden kaynaklanmaktadır (Fornbybarnorge, 2022). Norveç’in elektrik enerji üretiminin yaklaşık %95’ini karşılayan hidroelektrik, 1990 tarihli Enerji Yasası’nın enerji sektörünü serbestleştirmesiyle artış trendini yakalamış, son yıllarda küçük ölçekli hidroelektrik santrallerin kapasiteye eklenmesiyle daha da büyümüştür. Norveç’in enerji üretiminde çok küçük bir paya sahip olan güneş ve rüzgâr enerjisi, son yıllardaki kapasite artışı ve verilen hibeler sayesinde özellikle 2018 yılından sonra artış eğilimi göstermiştir. Norveç esasen düzenleyici bir politika olan kota uygulamasıyla yenilenebilir enerji kaynaklarını desteklemekle beraber bunun dışınca hibe ve vergiler yoluyla teşvik uygulamaktadır. Norveç satış vergisi ve emlak vergisi muafiyeti olmak üzere güneş enerjisi üzerinden vergi muafiyeti uygulamaktadır. Emlak vergisi hesaplanırken kurulu güneş enerjisi panelinin eve kattığı değer hesaplamadan düşülmektedir. Ayrıca 2006 yılından itibaren Federal Güneş Enerjisi Yatırım Vergi Kredisi (ITC) olarak uygulanan ve 2022 yılında Temiz Enerji Kredisi olarak güncellenen vergi kredisi uygulaması, vergi borcundan güneş enerjisi sistemine ait maliyetin önceden belirlenmiş bir yüzdesine eşit bir kredi sağlamaktadır. Ayrıca, 2021’de Norveç hükümeti, elektrikli araç sahiplerinin katma değer vergisi ödemekten muaf tutulduğunu duyurmuştur (Hivepower, 2021a).

Yenilenebilir enerji üretme kapasitesi %84 ile dünya ortalaması olan %38’in üzerinde olan Brezilya, dünyanın en büyük sekizinci elektrik üreticisidir (Cosimo vd., 2021:1286). Brezilya’da yenilenebilir enerji üretimi bakımından hidroelektrik, rüzgâr ve güneş enerjisi ilk üç sırada yer almaktadır. Brezilya, ülkenin elektrik altyapısını genişletebilmek için öncelikli olarak hidroelektrikten yararlanmaktadır. 1990’ların sonlarına kadar ülkedeki elektrik enerjisi potansiyelinin %90’ını karşılayan hidroelektrik enerji yerini 2000 ve 2002 yılları arasında yaşanan su kriziyle birlikte farklı kaynaklara bırakmıştır (Lima vd., 2020:7). Brezilya hidroelektrik enerjiye alternatif olarak rüzgâr endüstrisini teşvik etmek için kamu politikaları düzenlemiş ve 2014’ten itibaren rüzgâr enerjisi yatırımları ve üretiminde artışlar yaşanmıştır. Brezilya’nın uyguladığı mali teşvik politikası, güç, teknoloji ve enerji kaynağından bağımsız olarak tüketicilerin yakınında yapılan elektrik üretimi olarak adlandırılan dağıtılmış üretim (distributed generation) uygulamasının teşvik edilmesidir. Bunun için, güneş ve rüzgâr enerjisi üretiminde kullanılacak ekipman ve bileşenlerle yapılan işlemler için mal vergisinden muafiyet tanınmıştır (Neves, 2022). Ayrıca güneş ve rüzgâr enerjisi kurulumlarında kurulum ekipmanları katma değer vergisinden muaf tutulurken kurumlar vergisine ilişkin indirim uygulanmaktadır.

Fosil yakıtlar bakımından dışarıya bağımlı olan İsveç, nükleer enerji ve yenilenebilir kaynaklardan enerji ihtiyacını karşılamaktadır. İsveç, zengin bir akarsu ve biyokütle kaynağına sahip olması sebebiyle çoğunlukla elektrik üretiminde hidroelektrik ve ısıtma için biyoenerji olmak üzere temel iki yenilenebilir enerji kaynağı kullanmaktadır. Son yıllarda bu iki enerji kaynağına ek olarak rüzgâr enerjisine olan eğilim artmakla birlikte, elektriğin yaklaşık %45’i hidroelektrik ve %17’sinden fazlası rüzgâr enerjisinden elde edilirken, %8’i biyoyakıttan elde edilmektedir (Sweden.se, 2022). İsveç’te yalnızca kendi kullanımları için elektrik üreten bireyleri kapsayan bir vergi indirimi bulunmaktadır. Bu vergi indirimi, güneş panelleri, enerji depolama ve elektrikli araç şarj noktaları için alınabilmekte olup güneş panelleri için malzeme ve kurulum maliyetlerinde %20, piller ve şarj noktaları için ise %50 indirim sağlamaktadır (Hermansson ve Khill, 2022). Emlak vergisinde rüzgâr enerjisi santralleri için indirim uygulanırken diğer yenilenebilir kaynaklar fosil kaynaklarla aynı vergi oranına tabi olmaktadır. Ayrıca belli bir üretim kapasitesinin altında üretim yapan jeneratörlere vergi indirimi uygulanmakta olup bu oran yenilenebilir kaynaklı jeneratörler için daha yüksek bir üretim kapasitesini kapsamaktadır (Res-Legal, 2019). Bunlar dışında yenilenebilir enerji, temel olarak yatırım sübvansiyonları, Ar-Ge sübvansiyonları ve emisyon vergileri ile de desteklenmektedir.

Kanada, geniş kara kütlesi ve verimli coğrafi yapısıyla enerji üretmek için kullanılacak önemli yenilenebilir kaynaklara sahip olup bunlar hidroelektrik, rüzgâr, biyokütle, güneş, jeotermal ve okyanus enerjisinden oluşmaktadır. Kanada’da, yenilenebilir enerji kaynakları, toplam birincil enerji arzının yaklaşık %19’unu

karşılıklıdır. yenilenebilir enerji kullanan veya enerji tasarrufu sağlayan temiz enerji üretim ekipmanlarına yapılan ticari yatırımları teşvik etmek için iki vergisel teşvik uygulanmaktadır. Bunlardan birincisi “Sermaye Maliyeti Ödeneği” olup nitelikli yatırımlar için %30 ve %50 oranlarında sermaye maliyeti ödeneği sağlamaktadır. Bir diğer vergi teşviki olan “Kanada Yenilenebilir ve Koruma Harcamaları” ise sermaye maliyeti ödeneğine uygun projelerle ilgili bazı maddi olmayan başlangıç giderlerinin gerçekleştiği yılda tamamen düşülmesine, gelecek yıllarda kullanılmak üzere süresiz olarak devredilmesine veya hisseler yoluyla yatırımcılara aktarılmasına izin vermektedir (IEA, 2022a:119). Güneş enerjisi özelinde sağlanan ve konut sahiplerine evlerini daha enerji verimli hale getirmeleri için hibe veren Kanada Daha Yeşil Evler Hibesi (The Canada Greener Homes Grant) bir diğer teşvik uygulamasıdır. Güneş enerjisi için ayrıca faizsiz krediler sağlanmaktadır. İklim Eylem Teşvik Fonu (The Climate Action Incentive Fund) uygulaması yenilenebilir enerjiye yatırım yapan küçük ve orta ölçekli işletmeler için proje maliyetinin %25’ine varan indirimler sağlamaktadır. Bu programın finansmanı, federal hükümet tarafından toplanan karbon vergisi gelirinden karşılanmakta olup, toplanan tüm karbon vergisi geliri, çeşitli sübvansiyonlar şeklinde yenilenebilir enerjiye aktarılmaktadır (Solacity, 2022).

İspanya’da yenilenebilir enerji üretiminde en büyük rol rüzgâr enerjisine ait olup ardından sırasıyla hidroelektrik, güneş ve biyokütle gibi diğer yenilenebilir enerji kaynakları gelmektedir (IEA, 2022b:93). İspanya’nın yenilenebilir enerjisinin büyümesinin teşviki konusunda daha fazla önlem alması için Covid-19 salgınının, ihtiyaç duyduğu itici güç olduğunu söylemek yanlış olmayacaktır. Çünkü pandemi, İspanya’da yenilenebilir enerji sektörünün özelliklerini ele alan elektrik yasası, iklim değişikliği ve enerji geçişiyle ilgili yasa, ulusal enerji ve iklim planı, ulusal geri kazanım ve dayanıklılık planı gibi özel yasaları ve planları içeren genel bir yasanın oluşturulmasını sağlamıştır (Hivepower, 2021b). Bu yasalarla beraber yenilenebilir enerjiye yönelik sübvansiyonlar tanıtılırken kömür, doğalgaz ve petrol aramalarının yasaklanması yoluyla karbon emisyonunun azaltılmasının teşvik edilmesi ve enerji verimli binalara ve akıllı otomobil ve şarj istasyonlarına yapılan yatırımlar yoluyla temiz enerji geçişinin desteklenmesi hedeflenmiştir. İspanya vergi indirimi ve hibeler yoluyla teşvik uygulamaktadır. 2011’den itibaren evde yapılan yenilenebilir enerji uygulamaları (elektrik, su, gaz veya diğer tedarik tesisatlarının yenilenebilir enerji ile değiştirilmesi) için kişisel gelir vergisinde %20’lik bir gelir vergisi indirimi uygulanmaktadır. Hibeler ise yerel yönetimler aracılığıyla enerji tasarrufu ve verimlilik strateji planlarında belirlenen usul ve miktarlarda verilmektedir. Hibeler güneş enerjisi özelinde verilmekte olup maliyetin %37’sine kadar yararlanılabilmektedir. Ayrıca, zorunlu olmayan güneş enerjisi tesisatlarının teşvik edilmesi için yerel düzeyde sübvansiyon ve vergi avantajları da oluşturulmuştur. Yerel yönetimler kamu binaları başta olmak üzere maliyetin %50’sini aşmamak koşuluyla yerel bütçelerinden güneş enerjisi kurulumlarını teşvik edebilmektedir (Romero vd., 2013:204).

Türkiye önemli kömür yataklarına sahip olup petrol ve doğalgaz bakımından dışarıya bağımlıdır. Elektrik üretiminde kömür ve petrol kullanılmakla beraber, çok sayıda göl ve nehirleri sayesinde hidroelektrik kaynakları da yoğun şekilde kullanılmaktadır (Yapp, 2022). Son yirmi yılda, hızlı ekonomik büyüme ve nüfus artışı, yalnızca Türkiye’nin enerji talebindeki güçlü büyümeyi değil, aynı zamanda özellikle petrol ve doğalgazda dışarıya bağımlılığını arttırmıştır. Enerjide dışa bağımlılığı en aza indirmek için yerli ve yenilenebilir enerji üretimi, Türkiye’nin enerji politikasının temel hedefi olmuştur. Türkiye, yenilenebilir enerji kaynaklarının teşvik edilmesi konusunda daha çok düzenleyici politikalara yer vermekte olup bunlara ek olarak, yenilenebilir enerji yatırımlarını katma değer vergisi muafiyeti ve bazı gümrük vergilerinden muafiyetler de dahil olmak üzere genel bir teşvik sisteminden de yararlandırmaktadır.

Çalışmada ele alınan ülkelerin enerji tüketim miktarı, enerji tüketim neticesinde oluşan karbon salımı miktarı ve karbon salımına neden olan enerji tüketiminin yenilenebilir kaynaklarla ne ölçüde karşılanabileceğini incelemek üzere Tablo 3’te ilgili ülkelere ilişkin yüzölçümü, nüfus, kişi başına düşen GSYH, CO2 emisyonu, yenilenebilir enerji kaynaklarından üretilen toplam elektrik üretimi, toplam elektrik tüketimi ve yenilenebilir elektrik üretiminin toplam elektrik tüketimini karşılama yüzdesi 2021 yılı için verilmiştir.

**Tablo 3:** Seçilmiş Ülkelerin Enerji Görünümünün Açıklanmasına İlişkin Veriler (2021)

	Nüfus (Milyon)	Kişi Başı GSYH (Dolar)	Coğrafi Büyüklük (km <sup>2</sup> )	Toplam CO <sub>2</sub> Emisyonu (Mt)	Toplam Yenilenebilir Elektrik Üretimi (TWh)	Toplam Elektrik Tüketimi (TWh)	Yenilenebilir Elektrik Üretiminin Toplam Elektrik Tüketimini Karşılama Oranı (%)
Norveç	5,5	89.154	384.486	39,6	156,3	131,5	118,8
Brezilya	214,9	7.518	8.502.728	388,8*	464,1*	540,2*	85,9
İsveç	10,5	60.239	447.425	33,6	99,7	134,4	74,2
Kanada	37,42	52.051	9.984.670	528,9	421,7	562,8	74,9
İspanya	47,3	30.115	505.983	210,8	121,9	249,4	48,8
Türkiye	85,2	9.586	769.604	391,2	110,9	300,3	36,9

**Kaynak:** IEA ve Dünya Bankası verilerine dayanarak yazar tarafından oluşturulmuştur.

**Not:** \* işaretli sayılar, 2021 yılı verilerinin olmaması nedeniyle 2020 verileri belirtmektedir.

Tablo 3'e bakıldığında, özellikle İsveç, Norveç, Kanada ve Brezilya'nın toplam yenilenebilir elektrik üretiminin toplam elektrik tüketimini karşılayabilme oranının oldukça yüksek olduğu görülmektedir. Sırasıyla, Norveç %118, Brezilya %85, İsveç %74 ve Kanada %74 oranında elektrik tüketimini yenilenebilir elektrikten karşılayabilme gücüne sahiptir. Elbette bu durumda sayılan ülkelerin nüfusuna bağlı olarak elektrik tüketim miktarının az olmasının etkisi oldukça fazladır. Öte yandan bu oranlar gerçek üretim tüketim dengesini göstermemektedir. Zira, yukarıda sayılan ülkeler, enerji ihraç edilmesine bağlı olarak üretilen elektriğin tamamını kendi tüketimlerine harcamamaktadır. Ülkelerin tamamına bakıldığında nüfus miktarına bağlı olarak CO<sub>2</sub> emisyonu miktarı da değişmektedir. Diğer değişkenlerin sabit olduğu varsayıldığında her bir ülke için CO<sub>2</sub> emisyon miktarı azaldıkça elektrik tüketiminin yenilenebilir elektrikten karşılanma oranının da arttığı söylenebilir. Ancak bu konuda kesin bir yargıda bulunmak imkansızdır. Çünkü her bir ülkenin üretim yapısı, gelişmişlik düzeyi, nüfus yoğunluğu ile kirlilik arasındaki ilişkisi, elektrik enerjisinin yenilenebilir enerji dışındaki hangi kaynaklardan hangi oranda elde edildiği gibi birçok değişkene bağlı olarak yukarıdaki değişkenler arasındaki ilişki de değişebilmektedir.

**Tablo 4:** Seçilmiş Ülkelerin Net Sıfır Emisyon Hedefleri ve Yenilenebilir Kaynaklardan Üretilen Elektriğin Toplam Elektrik Üretimi İçerisindeki Payları (%)

	Net Sıfır Emisyon Hedefi	2005	2015	2022
Norveç	2050*	99,5	97,7	98,5
Brezilya	2050	87,1	74,1	89,2
İsveç	2045	51,3	63,3	68,5
Kanada	2050	59,8	64	68,8
İspanya	2050	15,9	35,7	43,1
Türkiye	2053	24,5	32	41,9

**Kaynak:** IEA ve Enerdata verilerine dayanarak yazar tarafından oluşturulmuştur.

**Not:** \* ile gösterilen hücre Norveç'in net sıfır emisyon hedefini göstermek üzere hazırlanmış olup Norveç, net sıfır emisyon hedefi belirtmemiştir. Norveç'in 2050 hedefi, emisyon salımını 1990 seviyelerinin %90-95 altına düşürmektir.

Tablo 4'te seçilmiş ülkelere ait net sıfır emisyon hedefleri ile bazı yıllarda yenilenebilir enerji kaynaklarından üretilen elektrik enerjisinin toplam elektrik enerjisi içerisindeki payları verilmiştir. Kyoto Protokolü ve Paris Anlaşması içerik olarak iklim değişikliği ile mücadele etmek üzere karbon emisyonunu sınırlamak üzere

ulusları çaba sarfetmeye teşvik eden yapılarıdır. Bu nedenle Tablo 4'te, Kyoto Protokolü'nün kabul edildiği 2005 yılı, Paris Anlaşmasının kabul edildiği 2015 yılı ve son olarak tüm ülkeler için en güncel verilere ulaşılabilen 2022 yılı itibarıyla ülkelerin yenilenebilir enerji kaynaklarından ürettikleri elektriğin toplam elektrik üretimi içerisindeki payları gösterilmiştir. Tablo 4'teki verilere bakıldığında, özellikle İspanya ve Türkiye'nin net sıfır emisyon hedefinden oldukça uzak olduğu görülmektedir. Sayılan ülkeler, Paris Anlaşması'ndan hareketle net sıfır emisyon hedefleri belirlemişlerdir. Covid-19 pandemisi, 2020 yılında CO2 emisyonunda benzeri görülmemiş bir düşüş sağlamıştır. Ancak Aralık 2020 itibarıyla CO2 emisyonları yeniden artmaya başlamıştır. Covid-19 pandemisinin neden olduğu azalma net sıfır emisyon hedeflerine ulaşılması konusunda pozitif etki yaratırken Uluslararası Enerji Ajansı (IEA), temel piyasa eğilimlerine bakıldığında, net sıfır emisyon hedefine ulaşmak için 2050'ye kadar gereken emisyon tasarruflarının neredeyse yarısının henüz ticari olarak mevcut olmayan teknolojilere dayandığını öne sürmektedir (IEA, 2021:30-33).

Bu durum göstermektedir ki, net sıfır emisyon hedefine ulaşılmasında her ne kadar teşvik politikaları uygulansa da hala kat edilmesi gereken mesafe fazladır. Çalışmada yalnızca mali teşvik politikaları ele alındığından duruma bu yönde bakılacak olursa sayılan ülkeler içinde özellikle Türkiye, mali teşvikler konusunda oldukça zayıftır. İsveç, Norveç gibi ülkeler, coğrafi yapısı gereği yenilenebilir enerji kaynakları bakımında avantajlı konumda olmakla beraber bu durumu uygulanan politikalarla daha da avantajlı hale getirmektedir. Örneğin Norveç ve İsveç, diğer ülkelerle kıyaslandığında güneşlenme süresi oldukça az olmasına rağmen güneş enerjisi konusunda mali teşviklere ağırlık vererek güneş enerjisi üretimini arttırmaya çalışmaktadır. Aynı şekilde rüzgâr enerjisi kurulumları için coğrafyası elverişli olmamasına rağmen deniz üstü rüzgâr santralleri kurulumlarını destekleyerek rüzgâr enerjisi üretimini arttırmaya çalışmaktadır. Ya da Brezilya hidroelektrik bakımından zengin konumdayken yaşanan su krizleri nedeniyle yenilenebilir enerji üretiminin azalmaması için rüzgâr ve güneş enerjisi üretimlerine özel mali teşvik uygulamalarıyla yenilenebilir enerji üretimini arttırmaya çalışmaktadır.

Türkiye'deki duruma bakıldığında ise 2053 yılına kadar net sıfır emisyon hedefinin oldukça gerisinde olduğu görülmektedir. Zira Türkiye 2021 sonunda, üretilen tüm yenilenebilir elektrik enerjisinin yine ülke içerisinde kullanıldığı varsayıldığında toplam elektrik tüketiminin yalnızca %37'sini karşılayabilecek durumdadır. Türkiye de diğer ülkeler gibi teşvik politikaları uygulamaktadır. Ancak bu uygulamalar daha çok düzenleyici teşvik politikaları olmakla birlikte mali teşvik politikaları ile ilgili yeni düzenlemelerin yapılması gerektiği ortadadır. Mevcut politikalar dahilinde (bu politikalar 2005 yılı itibarıyla uygulanmaya başlanmıştır) 2021 yılı sonunda net sıfır emisyon hedefinin yalnızca %35.2'si karşılandığına göre 2053 yılında net sıfır emisyon salımının gerçekleştirilmesi imkânsız görünmektedir. Bu durumda politika uygulayıcıların ya düzenleyici politikaları gözden geçirmesi gerekmekte ya da mali teşvik politikaları konusunda yeni düzenlemeler yaparak özellikle yenilenebilir enerji kaynaklarına yönelik vergisel teşvikler oluşturması gerekmektedir. Böylelikle, mevcut yenilenebilir enerji potansiyeli kullanılabilir hale getirilerek 2053 yılına kadar net sıfır emisyon hedefi daha gerçekçi bir hedef olabilecektir.

### Sonuç ve Değerlendirme

Yenilenebilir enerji kaynaklarının iklim değişikliği ile mücadele konusunda önemli bir yere sahip olduğu görülmektedir. Bu nedenle yenilenebilir enerji kaynaklarının teşvik edilmesi önem arz etmekte olup devletler tarafından düzenleyici ve mali politikalarla teşvik edilmektedir. Böylelikle emisyon salımının azaltılması sağlanarak iklim değişikliğiyle mücadele edilebilir. Ancak özellikle uluslararası çevre anlaşmalarından hareketle belirlenen net sıfır emisyon hedeflerine ulaşılması konusunda birçok ülke hedeflerin oldukça gerisinde bir yenilenebilir enerji üretimine sahiptir.

Bu çalışmada, yenilenebilir enerji kaynaklarından elektrik enerjisi üretimi konusunda son on yıllık süreçte dünya sıralamasında ilk sıralarda yer alan İsveç, Norveç, Brezilya, Kanada, İspanya ve Türkiye örnek ülke olarak alınmıştır. Bu örnek ülkelerde uygulanan mali teşvik politikaları, güncel yenilenebilir elektrik enerjisi üretimleri ile net sıfır emisyon hedefleri üzerinden mali teşvik politikalarının etkisi ve yeterliliği konusunda fikir sahibi olunmaya çalışılmıştır. Sayılan ülkeler içerisinde özellikle Türkiye net sıfır emisyon hedefinin oldukça gerisindedir. Çalışmada ele alınan diğer ülkelere bakıldığında yenilenebilir enerji kaynaklarından elektrik enerjisi üretimine yönelik birden fazla vergisel teşvik uygulaması ve hibe programı uygulaması olduğu görülürken, Türkiye'de yalnızca diğer yatırımlarında faydalandırıldığı genel bir vergisel teşvik

uygulanmasından bahsedilmektedir. Yani Türkiye, yenilenebilir elektrik enerjisi üretiminde yalnızca katma değer vergisi ile gümrük vergisine ilişkin teşvikler uygulamaktadır. Böylesi bir tabloda, mali teşvik politikalarını daha geniş tutan ülkelerin net sıfır emisyon hedeflerine daha yakın olmaları karşısında Türkiye'nin bu hedeften uzak olması beklenen bir durumdur.

Türkiye de diğer ülkeler gibi yenilenebilir enerji kaynaklarına yönelik mali teşvik politikaları konusunda genişlemeye giderek net sıfır emisyon hedefini daha gerçekçi bir zemine oturtmalıdır. Bunun için genel teşvik politikası kapsamı dışında yenilenebilir enerji kaynakları özelinde vergisel teşvik politikaları hatta hibe programları oluşturulması yerinde olacaktır. Aksi halde 2053 yılına kadar net sıfır emisyon hedefinin, kâğıt üzerinde yazılı bir hedef olmaktan öteye gitmesi beklenemez.

### Kaynakça

- Abolhosseini, S. & Heshmati, A. (2014). The Main Support Mechanisms to Finance Renewable Energy Development. *Renewable and Sustainable Energy Reviews*, 40(1), 876-885.
- Akdoğan, A. (2011). Kamu Maliyesi. 14. Baskı., *Gazi Kitabevi*, Ankara.
- Beck, F. & Martinot, E. (2004), Renewable Energy Policies and Barriers. *Encyclopedia of Energy*, 365-383.
- Büsching, H., Diego, M., Céline, C. & Carlo, G. (2020). Tax Incentives and Measures. 23.072023. <https://cms.law/en/int/expert-guides/cms-expert-guide-to-renewable-energy/tax-incentives-and-measures>
- Christensen, J. (2022). Norway. 01112023. <https://www.britannica.com/place/Norway>
- Cosimo, M., Marco, M. & Giovanna, M. (2021). The Relationship between Renewable Energy and Economic Growth in a Time of Covid-19: A Machine Learning Experiment on the Brazilian Economy. *Sustainability*. 13(3), 1285-1297.
- Donastorg, A. & Suresh, R. (2017). Financing Renewable Energy Projects in Developing Countries: A Critical Review. *Earth and Environmental Science*. 83(1), 1-9.
- Doran, K. (2023). Investment Tax Credit Vs. Production Tax Credit. 08092023. <https://smallbusiness.chron.com/small-business-grants-solar-energy-3625.html>
- Enerdata, (2023). World Energy & Climate Statistics – Yearbook 2023. <https://yearbook.enerdata.net/renewables/renewable-in-electricity-productionshare.html#text=>
- Fornybar Norge (2022). Energy Norway. 18072022. <https://www.fornybarnorge.no/om-oss/in-english/>
- Hermansson, N. & Omar, K. (2023). Recent developments in energy taxation in Sweden. 08092023. <https://setterwalls.se/en/article/recent-developments-in-energy-taxation-in-sweden/>
- Hivepower (2021a). Renewable Energy in Sweden: What You Should Know. 28092022. <https://www.hivepower.tech/blog/renewable-energy-in-sweden-what-you-should-know>
- Hivepower (2021b). Renewable Energy in Spain: What You Should know. 20092022. <https://www.hivepower.tech/blog/renewable-energy-in-spain-what-you-should-know>
- IEA (2021). Net Zero by 2050: A Roadmap For The Global Energy Sector. *International Energy Agency*, Paris.
- IEA (2022a). Canada 2020: Energy Policy Review. *International Energy Agency*, Paris.
- IEA (2022b). Spain 2021 Energy policy Review. *International Energy Agency*, Paris.
- IRENA (2023). Trends. 04012023. <https://www.irena.org/Energy-Transition/Finance-and-investment/Investment>
- Kalamova, M., Christopher, K. & Nick, J. (2011). Sources of Finance, Investment Policies and Plant Entry in the Renewable Energy Sector. *OECD Environment Working Papers*. 1-45.
- Liberto, D. (2022). Energy Tax Credit. 18082022. <https://www.investopedia.com/terms/e/energy-tax-credit.asp>



- Lima, M., Mendes, L., Mothé, G., Linhares, F. & Sthel, M. (2020). Renewable Energy in Reducing Greenhouse Gas Emissions: Reaching the Goals of the Paris Agreement in Brazil. *Environmental Development*. 33(1), 1-13.
- Neves, L. (2022) Brazil Introduces New Rules for Distributed Generation, Net Metering. 01102022. <https://www.pv-magazine.com/2022/01/10/brazil-introduces-new-rules-for-distributed-genera>
- Parry, I., Simon, B. & Karlygash, Z. (2022). Carbon Taxes or Emissions Trading Systems? Instrument Choice and Design. *International Monetary Fund*. Washington.
- REN21 (2022). Renewables 2022 Global Status Report. *Renewables Now*. Paris
- Res-Legal (2022). Sweden: Overall Summary. 04012023. <http://www.res-legal.eu/search-by-country/sweden/> (28.09.2022).
- Romero, M., Sánchez-Braza, A. & Pérez, M. (2013). Incentives to Promote Solar Thermal Energy in Spain. *Renewable and Sustainable Energy Reviews*. 22(3), 198-208.
- Sarıgül, S. & Topçu, B. (2021). The Impact of Environmental Taxes on Carbon Dioxide Emissions in Turkey. *International Journal of Business & Economic Studies*. 3(1), 43-54.
- Schmalensee, R. & Stavins, R. (2017). Lessons Learned from Three Decades of Experience with Cap and Trade. *Review of Environmental Economics and Policy*. 11(1), 1-26.
- Shrimali, G., Sandhya, S., Shobhit, G. & David, N. (2017), The Effectiveness of Federal Renewable Policies in India. *Renewable and Sustainable Energy Reviews*. 70(1), 538-550.
- Smoot, G. (2022). Carbon Emissions Trading vs Carbon Taxes: What's the Difference?. 25082022. <https://impactful.ninja/carbon-emissions-trading-vs-carbon-taxes-differences/#:~t>
- Solacity (2022). Solar Incentives and Rebates in Canada. 30092022. <https://www.solacity.com/solar-rebates-and-incentives-incanada/#:~:text=The%20Climate%>
- Sweden.se (2022). Energy Use in Sweden. 28092022. <https://sweden.se/climate/sustainability/energy-use-in-sweden>
- Şen, H. & Sağbaş, İ. (2016). Vergi Teorisi ve Politikası. *Barış Arıkan Yayınları*. Ankara.
- Yapp, E. M. (2022), Türkiye. 15112022. <https://data.worldbank.org/country/TR>



### CONSUMER PREFERENCES ON ELECTRIC VEHICLES: A COMPARISON STUDY APPLYING TOPSIS AND VIKOR METHODS AS MULTI CRITERIA DECISION ANALYSES

**Metin CANCI**

Prof. Dr., Yalova University, Faculty of Economics and Administrative Sciences, Department of International Trade and Finance, Yalova-Türkiye, (Responsible Author) ORCID: 0000-0002-2152-0975

**Gizem ALKAN KABAKCI**

Industrial Engineer, Stellantis N.V., Bursa-Türkiye, ORCID: 0000-0002-3676-0760

#### ABSTRACT

Nowadays, it is obvious that electric vehicles become more popular comparing to recent 10 years and all around the world electric vehicles will be the one most important widespread technology in automotive industry. Referring to consumer behaviours, this study provides insight into motivational reasons of consumers' preferences for electrical vehicles applying Vikor and Topsis methods as multi criteria decision analyse. As a starting point of this study, thanks to the international literature review, the main intentions by choosing and compensating the electric vehicles were deeply investigated. Related to literature review, twenty various criteria was arranged in order to establish a multi criteria decision analyse. In terms of defining alternatives, five different electrical vehicle models from Japan, Vietnam, South Korea, China and Turkey were allocated entire the several options and they were respectively evaluated per each criteria by surveys. Best alternatives according to Topsis and Vikor methods were calculated as an exact result of the study. During the study, defined weights of the each criteria was the most important bridge between numerical consistency of study and results reliability of calculations. As a conclusion, this study contributes to an important comparison of five different electric vehicle model according to consumer preferences and behaviours while this will provide the one of important example for Topsis and Vikor methods applications in electric vehicle as an advancing and growing area of automotive industry.

**Keywords:** Consumer Preference, Electric Vehicles, Topsis, Vikor



### YENİLENEBİLİR ENERJİ ve DOĞALGAZ TÜKETİMİNİN İNSANİ GELİŞMEYE ETKİSİ: RALS FADL YAKLAŞIMI

**Funda DURGUN**

Öğr. Gör. Dr., Dicle Üniversitesi İktisadi ve İdari Bilimler Fakültesi İktisat Bölümü, Diyarbakır-Türkiye,  
ORCID: 0000-0001-7254-227X

**Şener İLTER**

Arş. Gör. Dr., Dicle Üniversitesi İktisadi ve İdari Bilimler Fakültesi İktisat Bölümü, Diyarbakır-Türkiye, (Sorumlu Yazar)  
ORCID: 0000-0002-0255-2656

#### ÖZET

Enerji tüketiminin ekonomik büyüme ile ilişkisinin analiz edilmesi büyüme sürecinde enerji politikaları dizayn edilirken faydalı bilgiler verebilmektedir. Büyümeyle ilişkisi birçok çalışmada kanıtlanmış olan enerji tüketiminin büyümeden farklı olarak bireylerin bilgi, yetenek ve sağlık durumlarını göz önüne alan kalkınma göstergelerini de etkilemesi muhtemeldir. Enerji tüketiminin kalkınma üzerindeki rolünün belirlenmesi, toplumun eğitim ve sağlık düzeyinin yükseltilmesinde enerjinin araç olarak kullanılmasını sağlayabilmektedir. Bu çalışmada, 1990-2020 döneminde Türkiye’de birincil enerji yoğunluğu, yenilenebilir enerji tüketimi ve doğalgaz tüketiminin insani gelişmeye etkisi analiz edilmiştir. Kalıntıların normal dağılmadığı varsayımı altında çalışan ve esnek kırılmalara izin veren RALS-FADL eşbütünleşme testi sonuçları değişkenler arasında uzun dönemli bir ilişki olduğunu ortaya koymuştur. Uzun dönem esnekliklerine göre doğalgaz tüketimi ve yenilenebilir enerji tüketimi insani gelişmeyi artırırken birincil enerji yoğunluğu insani gelişmeyi azaltmaktadır. Ancak birincil enerji yoğunluğunun insani gelişme üzerindeki olumsuz etkisi daha güçlüdür. Değişkenler arasındaki nedensel bağlantılar zamanla değişen nedensellik testi ile tahmin edilmiştir. İnsani gelişmeden yenilenebilir enerji tüketimine, doğalgaz tüketiminden insani gelişmeye ve enerji yoğunluğundan insani gelişmeye doğru tek yönlü nedensellik ilişkisi bulunmuştur. Bu sonuçlara göre, birincil enerji yoğunluğunun azaltılması bireylerin seçimlerinin genişletilmesinde önemli rol oynamaktadır. Enerji yoğunluğu azaltılırken, tasarruf edilen enerjinin karbon salınımı yapan petrol ve kömürden yapılması insani gelişme üzerindeki olumlu etkinin güçlenmesini sağlayabilecektir. Son olarak üretim sürecinde çevre üzerindeki baskının azaltılması için yenilenebilir enerji yatırımlarının artırılması gerekmektedir.

**Anahtar Kelimeler:** Yenilenebilir enerji tüketimi, doğalgaz tüketimi, enerji yoğunluğu, insani gelişme, RALS-FADL eşbütünleşme testi.

#### THE IMPACT OF RENEWABLE ENERGY AND NATURAL GAS CONSUMPTION ON HUMAN DEVELOPMENT: RALS FADL APPROACH

#### ABSTRACT

Analyzing the relationship between energy consumption and economic growth can provide useful information for designing energy policies in the growth process. Energy consumption, whose relationship with growth has been proven in many studies, is likely to affect development indicators that take into account the knowledge, skills and health status of individuals in addition to growth. Determining the role of energy consumption in development can enable energy to be used as a tool for improving society's education and health levels. This study analyzes the impact of primary energy intensity, renewable energy consumption and natural gas consumption on human development in Türkiye for the period 1990-2020. The results of the RALS-FADL cointegration test, which works under the assumption that the residuals are not normally distributed and allows for flexible breaks, reveal that there is a long-run relationship between the variables. According to the long-run elasticities, natural gas consumption and renewable energy consumption increase human development, while primary energy intensity decreases human development. However, the negative impact of primary

energy intensity on human development is stronger. The causal linkages between the variables are estimated with the time-varying causality test. Unidirectional causality was found from human development to renewable energy consumption, from natural gas consumption to human development and from energy intensity to human development. According to these results, reducing primary energy intensity plays an important role in enlarging people's choices. While reducing energy intensity, the positive impact on human development will be strengthened if the energy saved is provided by carbon emitting oil and coal. Finally, investments in renewable energy need to be increased in order to mitigate the pressure on the environment in the production process.

**Keywords:** Renewable energy consumption, natural gas consumption, energy intensity, human development, RALS-FADL cointegration test.



## FORECASTING SOLAR PANEL ELECTRICITY PRODUCTION AND ANALYZING ECONOMIC VIABILITY CONSIDERING CARBON PRICES

**Umut ERCAN**

Asst. Prof. Dr. Batman University, Besiri Vocational School, Batman -Türkiye, (Responsible Author)  
ORCID: 0000-0003-1063-4480

**Muzaffer ALIM**

Asst. Prof. Dr. Batman University, Besiri Vocational School, Batman -Türkiye  
ORCID: 0000-0002-4420-7391

### Abstract

To mitigate carbon emissions, identified as a key contributor to the climate crisis and global warming, transitioning to sustainable energy sources is imperative. In this direction, investments in solar energy is getting increasingly significant in the transition towards sustainable energy systems. Due to some seasonal and geographical limitations, accurate forecasting of solar panel electricity generation is vital for effective energy planning, grid integration, and policy formulation. In this study, we apply various mathematical techniques for forecasting solar panel electricity production, integrating radiation data from the target area. Employing advanced forecasting models and machine learning algorithms, we extrapolate electricity generation patterns based on historical radiation data. The resulting forecasts serve as a foundational tool for stakeholders in making informed decisions regarding solar energy integration. Furthermore, this paper evaluates the economic aspect of solar energy investment by considering the prevalent carbon prices. Given the imperative to reduce carbon emissions, carbon pricing is a pivotal mechanism influencing the economics of renewable energy investments. Our analysis evaluates the financial viability of solar panel investments by incorporating carbon prices into the cash flow. The study provides insights into the potential returns and cost-effectiveness, enabling stakeholders to optimize investment strategies and contribute to a greener, more sustainable future.

**Keywords:** Solar energy, Electricity production forecasting, Carbon prices, Sustainable energy, Energy economics

### 1. Giriş

Günümüzde enerji talebinde görülen sürekli artış ve iklim değişikliği, küresel ısınma gibi çevresel endişeler, temiz, sürdürülebilir ve verimli enerji kaynaklarına olan yönelimi giderek daha da arttırmaktadır. Bu bağlamda, güneş ışınımının ve fotovoltaik (Güneş) enerji teknolojilerinin gelecekteki önemi de giderek artmaktadır. Güneş enerjisi, fosil yakıtlara dayalı enerji üretimine göre daha düşük karbon salınımı ile çok daha temiz ve çevre dostu bir seçenektir.

Güneş enerjisi, dünya için yenilenebilir, temiz, güvenilir, sınırsız, sürdürülebilir bir enerji kaynağıdır. Aynı zamanda dünyanın enerji ihtiyacını karşılama konusunda da büyük bir potansiyele sahiptir. Bir bölgenin güneş enerjisi potansiyelinin belirlenebilmesi için o bölgenin öncelikle global güneş radyasyon verilerinin bilinmesi gereklidir. Güneş enerjisi alanındaki çalışmaların ve yatırımların doğru planlanması, amacına ulaşması, yönetilmesi ve uygulanması için global güneş radyasyon miktarının başarılı ve doğru bir şekilde ölçülmesi ya da geçmiş yıllara dayalı veriler üzerinden gelecek için tahmin edilmesi en dikkat edilecek hususların başında gelmektedir. Enerji ihtiyacı olan ve bu enerjiyi güneş enerjisinden karşılaması istenen yatırımların sağlam temeller üzerinde durması için güneş radyasyon değerlerinin tahmininin doğru yapılması önemlidir. Doğru global güneş radyasyon değeri tahmininde bulunmak, enerji ihtiyacı bulunan bütün kesimlerin kâr marjını doğrudan doğruya etkilemektedir.

Bu çalışma, geçmiş dönem ışınım değerlerine göre gelecekteki tahminleri ile bu tahminlere bağlı olarak üretilecek elektrik enerjisinin hesaplanması konusuna odaklanmaktadır. Güneş ışınımının gelecekteki değişimlerini öngörmek ve bu değişimleri kullanarak güneş enerjisi üretimini tahmin etmek, enerji planlaması

ve yatırım kararları süreçlerinde oldukça büyük bir öneme sahiptir. Ayrıca, ekonomik analizde bugün pek çok ülke tarafından uygulanan karbon fiyatlarını dikkate alarak, güneş enerjisinin ekonomik sürdürülebilirliği ve fosil kaynaklarla rekabetçiliği üzerindeki etkileri değerlendirilecektir. Ülkelerin hedefledikleri sıfır emisyon hedeflerine ulaşmaları için karbon fiyatlamasını ve kotasının giderek daha sıkı bir şekilde takip edileceği ve bu nedenle de bunun enerji yatırımlarında gözetilmesinin daha doğru bir analiz imkânı sunacağı öngörülmektedir.

## 2. Literatür Araştırması

Global güneş radyasyonunun tahmini, kısa, orta ve uzun vadeli ortalama meteorolojik verilere ihtiyaç duymaktadır. Sonuçların güvenilirliği ve hata payının az olması için uzun süreli veriler kullanılmalıdır. Araştırmacılar tahmin modelleri geliştirmek için farklı parametreler ve farklı modeller kullanmaktadırlar. Bu çalışmalardan bazıları aşağıda kısaca özetlenmiştir.

Acet (2023), yaptığı çalışmada farklı iklim kuşaklarında yer alan üç farklı şehir için 2015-2020 yılları arasındaki global ışınım değerlerini kullanarak, ARIMA ve yapay sinir ağı yöntemleri ile 2021-2022 yılları için güneş potansiyeli tahmini yapmıştır. Elde edilen sonuçlara göre kullanılan iki modelde de en uyumlu çıkan şehir İstanbul olduğu görülmüştür. Kisi ve ark. (2019), yaptıkları çalışmada Devlet Meteoroloji Genel Müdürlüğünden alınan Adana ve Antakya konumları (istasyonları) için minimum ve maksimum sıcaklık ve global radiation verilerinden yararlanılarak dynamic evolving neural-fuzzy inference system (DENFIS) modelinin uygulanabilirliği araştırılmıştır. Sonuçlara bakıldığında Antakya istasyonu DENFIS modeli kullanılarak diğer modellere daha iyi tahmin sonuçları olduğu görülmüştür. Yao ve ark. (2018), yaptıkları bu çalışmada, hava kalitesi indeksini (AQI) ek bir girdi parametresi olarak alınmış ve global güneş ışınımını yatay bir düzlemde tahmin etmek için bir destek vektör makinesine (SVM) dayalı bazı yeni modeller önermişlerdir. Yapılan analiz ve hesaplamalar sonucunda SVM-1 ve SVM-2 modellerinin hata payları karşılaştırılmış, R değerinin sırasıyla 0,848'den 0,876'ya gösterilmiştir. NSE değeri 0,682 ve 0,740'a, RMSE değeri 0,114 ve 0,102 MAPE değeri ise 9,257 ve 8,214 olarak hesaplanmıştır. Lazzús ve ark. (2011), Şili'deki La Serena için saatlik küresel güneş radyasyonunu tahmin etmek amacıyla Yapay Sinir Ağları modeli kullanmışlardır. Sisteme 5 yıllık (2001–2005) yılları ışın değerleri ile rüzgâr hızı, bağıl nem, hava sıcaklığı ve toprak sıcaklığı içeren bir model kullanmışlardır ve *R2 değerini* %94 olduğu bulmuşlardır.

Yapılan çalışmada Nijerya'daki farklı iklim koşullarında seçilen 7 lokasyon için aylık olarak Şubat 2004 ile Nisan 2018 yılları arasındaki global güneş radyasyon verileri The Copernicus Atmosphere Monitoring Service Information'dan elde edilmiştir (Ozoegwu, 2019). Alınan verileri NARX ANN zaman serisi tahmini için MATLAB GUI kullanılmış, hibrit ANN için özel bir MATLAB kodu geliştirilmiştir. Önerilen hibrit yöntemin, %5,67'lik tipik ortalama yüzde tahmin hatası dahilinde iki yıla kadar daha uzun vadeli tahmin yapma kapasitesi olduğu gösterilmiştir. Ouammi ve ark. (2012), Fas'taki 41 bölgenin aylık güneş ışınımını tahmin etmek için yapay sinir ağları modeli kullanmışlardır. 1998'den 2010 yılına kadar olan veriler kullanılmıştır. Tahmin edilen güneş ışınımı 5030 ile 6230 Wh/m<sup>2</sup>-gün arasında değişmektedir. Wang ve ark. (2021), fotovoltaik bir serada fotovoltaik enerji üretimi ve tarımsal üretim için yıllık ekonomik faydaların maksimum düzeye çıkarılmasına dayanan bir güneş radyasyonu dağıtım yöntemi önermektedir. Çalışmaları, genel ekonomik faydaları en üst düzeye çıkarmak için fotovoltaik enerji üretimi ile tarımsal üretim arasındaki güneş radyasyonu dağılımını optimize etme zorluğunu ele alıyor. Doğru güneş radyasyonu tahmini, bu tür optimizasyon stratejilerinin uygulanmasında çok önemli bir rol oynar. Ayrıca Jain ve ark. (2012), güneş radyasyonundaki belirsizliğin proje ekonomisi ve performansı üzerindeki etkisini ölçmek için bir duyarlılık analizi sunmaktadır.

Asirin ve ark. (2023) ise güneş enerjisinin fayda maliyet analizine ilişkin kapsamlı bir literatür taraması sunmaktadır. Güneş enerjisi yatırımlarının doğru analizi için tüm yaşam ömrünün dikkate alınması gerektiğini ve doğru bir güneş radyasyon tahmini ihtiyacı olduğunu vurgulamaktadırlar. Lu ve Davison (2013) ise farklı çevresel koşullar altında güneş enerjisi yatırımlarının geri ödeme sürelerini analiz etmektedir.

Güneş ışınımının belirlenmesi, güneş sistemi tasarımı, enerji üretimi ve güneş enerjisi araştırmaları için öncelikli olarak gerekli olduğu görülmüştür. Bu bağlamda yapılan literatür araştırmasında da yatay ve eğimli yüzeylerdeki güneş ışınımını tahmin etmek için farklı makine öğrenmesi teknikleri kullanılmakta olduğu görülmüştür. Fakat birçok çalışma karbon fiyatlamasının etkisini göz ardı etmektedir. Bu nedenle bu çalışma yapılan tahmine bağlı olarak ekonomik analizde karbon fiyatını da dikkate almaktadır.

### 3. Güneş Enerjisinden Elektrik Üretimi

Güneşten yayılan ısı ve ışık kaynağına güneş enerjisi denir. Güneş enerjisi dünya ve insan yaşamı ve her türlü canlı için hayati öneme sahip bir enerji kaynağıdır. Dünya'ya gelen Güneş ışınlarında doğal ve yapay dönüşümler olmak üzere iki şekilde faydalanılır.

Ülkemizde Güney Doğu Anadolu bölgesi güneş enerji potansiyeli bakımında ilk sırada yer almaktadır. Güneş enerji potansiyeli en düşük olan bölge ise Karadeniz Bölgesidir.



Şekil 1. Türkiye Güneş Potansiyeli Haritası (GEPA, 2023)

Şekil 2'de Türkiye geneli Global Radyasyon değerleri verilmiştir. Türkiye'de güneşlenme saatinin en çok olduğu ay haziran ayı, aralık ayı ise güneşlenme saatinin en az olduğu aydır.

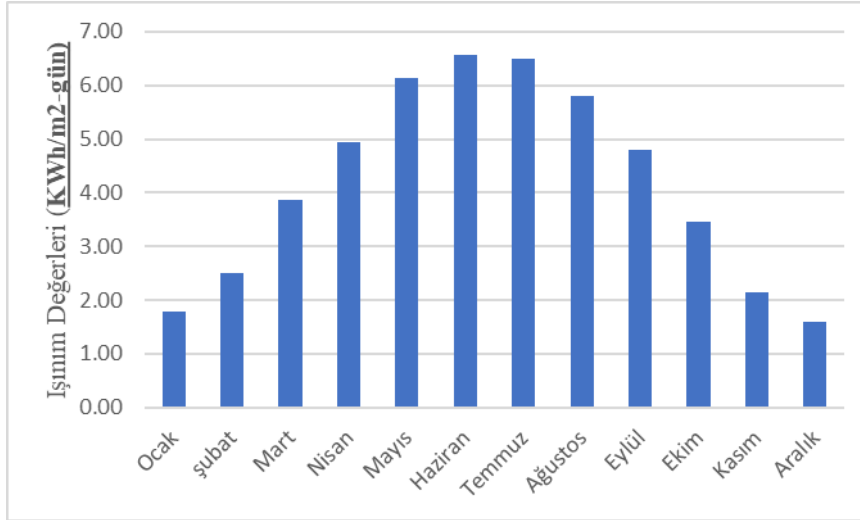

Şekil 2. Türkiye Global Radyasyon Değerleri (KWh/m2-gün) (GEPA, 2023)

Şekil 3'te TÜRKİYE geneli güneşlenme süreleri (saat) aylık olarak verilmiştir. Ülkemiz günlük olarak bakıldığında güneşlenme zamanı yaklaşık 7,49 saat/gündür. Bir yıllık güneşlenme saatinin toplamı yaklaşık 2736,89 saat-yıl (7,49x365) dır. Bu değerler göz önüne alındığında Türkiye'nin güneşlenme süresine göre yüksek bir potansiyeli vardır.

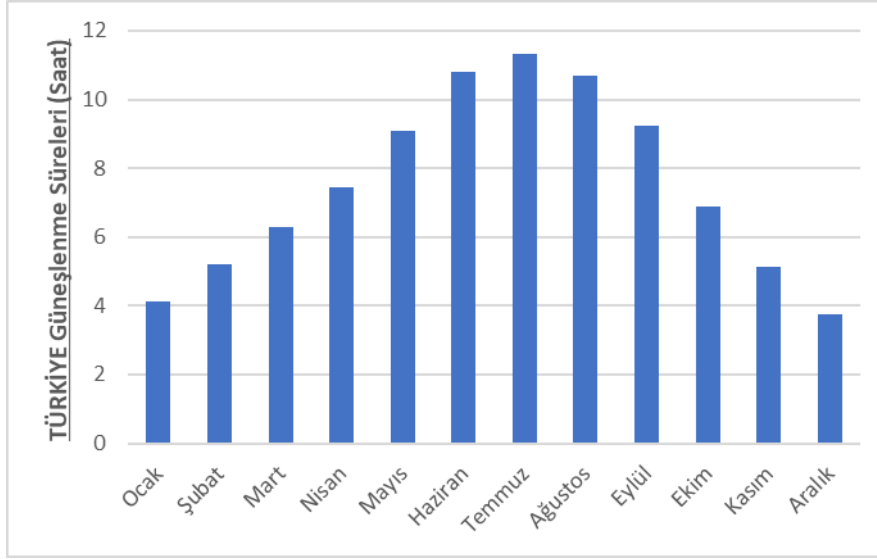

Şekil 3. Türkiye Güneşlenme Süreleri (Saat) (GEPA, 2023)

#### 4. Güneş Enerjisi Tahmini

Güneş radyasyon değerlerinin tahmin edilmesi, belirli bir yer ve zaman aralığındaki güneş radyasyon miktarını tahmin etme işlemi olarak tanımlanabilir. Fotovoltaik paneller gibi güneş enerjisi sistemleri elektrik üretmek için güneşe ihtiyaç duymaları nedeniyle ürettikleri enerji miktarı günün saati, bulut örtüsü ve güneşin açısı gibi faktörlere bağlı olarak değişebilir. Bu da bir yatırım planı yapılırken enerji potansiyelinin tahmin edilmesinin ne kadar önemli olduğunu göstermektedir.

Doğru güneş enerjisi tahmini, kamu hizmetlerinin, işletmelerin ve bireylerin güneş enerjisindeki potansiyel değişiklikleri planlamasına ve bunlara uyum sağlamasına olanak tanıyarak güneş enerjisi kullanımının optimize edilmesine yardımcı olur. Ayrıca yedek güç kaynaklarına olan ihtiyacın azaltılmasına ve güneş enerjisi sistemlerine güvenilirliğin artırılmasına katkı sağlar. Genel olarak, güneş enerjisinin kullanımı ve doğru güneş enerjisi tahmini, yenilenemeyen enerji kaynaklarına bağımlılığı azaltarak, sera gazı emisyonlarını düşürerek ve enerji güvenliğini iyileştirerek sürdürülebilirliğin desteklenmesine yardımcı olabilir.

Mevsimsel ARIMA modeli, bir zaman serisi veri setindeki gelecek değerleri tahmin etmek için kullanılan istatistiksel bir yöntemdir. ARIMA, Otoregresif Entegre Hareketli Ortalama anlamına gelmektedir ve gelecek dönem tahminleri için geçmiş dönem verileri kullanan bir tür matematiksel yaklaşımdır. Verilerde mevsimsellik gözlemlendiği durumlarda ARIMA modelin mevsimsel bileşenleri de belirlenir. Modelin mevsimsel bileşeni, yılın belirli bir zamanında meydana gelen verilerde yinelenen kalıpları veya eğilimleri hesaba katabileceğini ifade etmektedir. Klasik bir ARIMA modelinde (p,d,q) olmak üzere üç parametre varken mevsimsel modelde bu parametrelere ek olarak (P,D,Q) mevsimsel bileşenleri dâhil edilir. Seçilen mevsimsellik periyoduna göre modelin gerçek veriye en çok uyum sağlayacağı şekilde bu parametreler belirlenir ve modelin hata değerleri ölçülür. Genel olarak, mevsimsel ARIMA modeli, bir zaman serisi veri setinde gelecekteki değerleri tahmin etmek için güçlü bir araçtır. Çünkü yinelenen kalıpları veya eğilimleri hesaba katara daha doğru tahminler yapılmasını sağlar.

Bu çalışmada, Meteoroloji Batman Müdürlüğünden alınan Batman ilindeki 2018-2022 global güneş radyasyon verileri baz alınarak aylık ışınım değerlerine göre gelecek dönem ışınım değerleri tahmin edilmiştir. Bu tahmini yapmak için ARIMA zaman serisi yöntemi kullanılmıştır. Güneş ışınım değerleri mevsimsellik gösterdiği için 12 periyotlu bir mevsimsel ARIMA yöntemi tercih edilmiştir. Bu metodun yanında mevsimsel olmayan ARIMA yöntemi de çalıştırılarak sonuçları karşılaştırılmıştır.



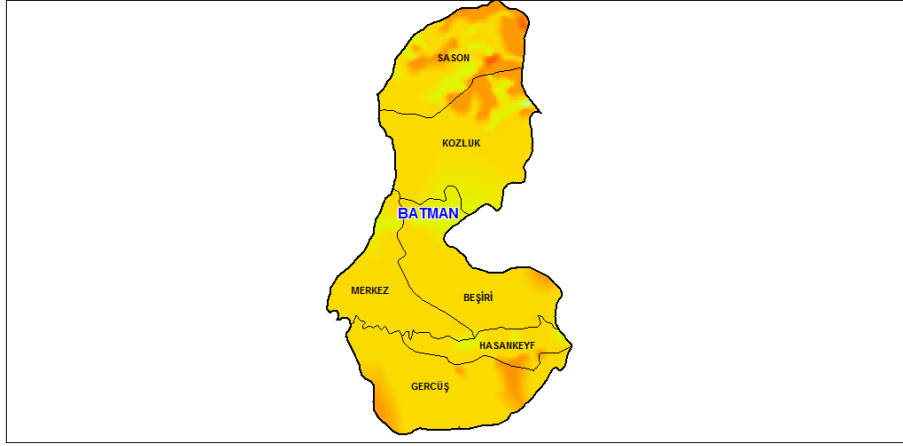

Şekil 4. Batman İli Güneş Enerji Potansiyeli Haritası

Tablo 1. Tahmin Yöntemleri Hata Değerleri

Yöntem	Model	Ortalama Mutlak Hata	Ortalama Hata Karesi
ARIMA	ARIMA(2,0,1)	12.573	15.421
ARIMA mevsimsel	ARIMA(0,0,0(0,1,0)[12]	3.556	7.697

Hata değerleri mevsimsel ARIMA modeli için çok daha küçük çıkmaktadır. Bu nedenle mevsimsel ARIMA modelini ışınım değerlerini tahmin için kullanılmasının daha uygun olduğu görülmüştür. Gerçek değerler ile mevsimler ARIMA değerlerinin karşılaştırması ise Şekil 5'te verilmiştir. Şekil 5'te mavi ile gösterilen değerler gerçek değerleri temsil ederken kırmızı mevsimsel ARIMA modelinin sonuçlarını göstermektedir. ARIMA modeli pek çok noktada gerçek veriye oldukça uyumlu hareket etmekte ve dip-tepe noktaları yakalamada oldukça başarılı bir performans sergilemektedir.

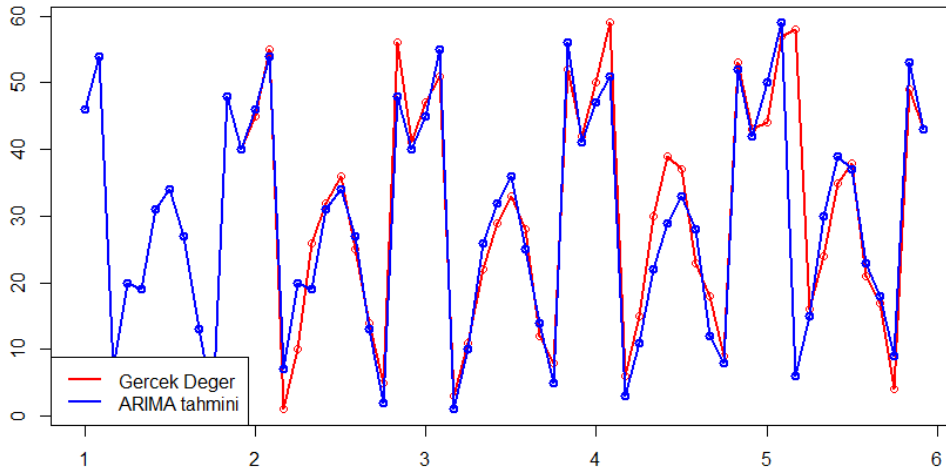

Şekil 5. ARIMA tahmini ve Gerçek Değerlerin Karşılaştırılması

## 5. Ekonomik Analiz

Batman ili için kurulması planlanan 1 m<sup>2</sup>'lik bir güneş paneli için ekonomik analiz yapılmıştır. Yapılan analize göre bu alana kurulacak panelin kurulum maliyeti 700 \$, panel verimi %22 ve panelin ortalama ömrü 20 yıl

olarak ele alınmıştır. Enerji ve Tabii Kaynaklar Bakanlığı verilerine göre Türkiye’de ortalama 1MWh elektrik üretimi karşılığında 0.440 ton CO<sub>2</sub> açığa çıkmaktadır. Burada ele alınan panel, 20 yılda yaklaşık olarak 7.6 MWh elektrik üretimi yapmaktadır. Güneş temiz bir enerji kaynağı olduğu için bu miktardaki üretim de Türkiye’deki karbon salınımını yaklaşık olarak 3.33 ton azaltacaktır. Farklı karbon fiyatları göz önüne alındığında bunun birim elektrik üretim maliyetine etkisi Tablo 2’de özetlenmiştir.

Tablo 2. Karbon Fiyatlarına Göre Birim Enerji Maliyet

Karbon fiyatı	C=0	C=10	C=25	C=50	C=100
Birim maliyet (\$/kwh)	0.095	0.088	0.082	0.071	0.049

Tablo 2’den de açıkça görüleceği üzere Avrupa Birliği ve gelişmiş bazı ülkelerde uygulanan karbon fiyatlandırmasının ülkemizde de uygulanması halinde güneş enerjisi yatırımları daha cazip hale gelecektir. Böylelikle de güneşten üretilen elektrikte birim maliyet daha da düşecektir. Türkiye’nin Paris iklim anlaşması dahil olması ve sürdürülebilirlik hedefleri doğrultusunda karbon fiyatlamasının da ileriki dönemde ülkemizde de uygulanabileceği öngörülmektedir.

## 6. Sonuç ve Öneriler

Batman ilindeki 2018-2022 verilerine dayalı olarak aylık ışıınım değerlerine göre gelecek dönemler için ışıınım değerleri tahmini yapılmıştır. Bunun için ARIMA zaman serisi yöntemi kullanılmıştır. Güneş ışıınım değerleri 12 periyotlu bir mevsimsel ARIMA yöntemi tercih edilmiştir. Bunun yanında mevsimsel olmayan ARIMA metodu da çalıştırılarak ortaya çıkan sonuçlar karşılaştırılmıştır.

ışıınım değerlerine bağlı olarak olası güneş enerji yatırımlarının geri ödeme süreleri ve fizibilite çalışmaları yapmak doğru bir yatırım için oldukça faydalı analitik destek sağlayacaktır. Sadece zaman zaman daha iyi ışıınım değerlerine sahip olmak yatırım için yeterli olmayabilir. Çünkü tüm dönem boyunca yapılacak üretim kısa süreli yapılacak enerji üretiminden daha ekonomik olabilir. Ülkemizin de dahil olduğu Paris Antlaşması ile küresel ısınma ve iklim değişikliği ile mücadelede karbon salınım miktarı önemli hale gelecektir. Güneş enerjisinden elektrik üretiminin fiyatlandırılmasında CO<sub>2</sub>’nin ton başına düşen fiyatı arttıkça, bu yöntemin maliyeti düşmektedir.

ışıınım değerleri tek başına yeterli bir ölçü olmayıp sadece genel bir potansiyel göstermektedir. Buna ek olarak havanın kapalılık durumu, panelin açısı gibi farklı mevsimsel ve operasyonel parametrelerin de dikkate alınması daha doğru, daha hassas bir analiz yapmak için gereklidir.

## 7. Kaynaklar

Acet, N. (2023). Farklı iklim koşulları için ışıınım değerlerine dayalı güneş enerjisi potansiyelinin tahmini. Master's thesis, Batman Üniversitesi Lisansüstü Eğitim Enstitüsü.

Asirin, N., Siregar, H., Juanda, B., & Indraprahasta, G. (2023). Cost-benefit analysis framework for utility-scale solar energy development: a life cycle approach. *Iop Conference Series Earth and Environmental Science*, 1220(1), 012040. <https://doi.org/10.1088/1755-1315/1220/1/012040>

Jain, A., Vu, T., Mehta, R., & Mittal, S. (2012). Optimizing the cost and performance of parabolic trough solar plants with thermal energy storage in india. *Environmental Progress & Sustainable Energy*, 32(3), 824-829. <https://doi.org/10.1002/ep.11660>

Kisi, O., Heddami, S., & Yaseen, Z. M. (2019). The implementation of univariable scheme-based air temperature for solar radiation prediction: New development of dynamic evolving neural-fuzzy inference system model. *Applied Energy*, 241, 184-195.

Lazzús, J. A., Pérez Ponce, A. A., & Marín, J. (2011). Estimation of global solar radiation over the city of La Serena (Chile) using a neural network. *Applied Solar Energy*, 47(1), 66-73.

Lu, B. and Davison, M. (2013). Analyzing the impact of environmental variables on the repayment time for solar farms under feed-in tariff. *Environmental Systems Research*, 2(1), 5. <https://doi.org/10.1186/2193-2697-2-5>

Ouammi, A., Zejli, D., Dagdougui, H., & Benchrifa, R. (2012). Artificial neural network analysis of Moroccan solar potential. *Renewable and Sustainable Energy Reviews*, 16(7), 4876-4889.

Ozoegwu, C. G. (2019). Artificial neural network forecast of monthly mean daily global solar radiation of selected locations based on time series and month number. *Journal of Cleaner Production*, 216, 1-13.

Yao, W., Zhang, C., Hao, H., Wang, X., & Li, X. (2018). A support vector machine approach to estimate global solar radiation with the influence of fog and haze. *Renewable Energy*, 128, 155-162.

Wang, Y., Zhou, T., & Zhou, W. (2021). Solar radiation distribution method for a photovoltaic greenhouse based on the maximization of annual economic benefits.. <https://doi.org/10.21203/rs.3.rs-289402/v1>

<https://gepa.enerji.gov.tr/MyCalculator/>

<https://www.enerji.gov.tr/anasayfa>

## II. International Energy Days

September 27<sup>th</sup>, 2023 / Sivas-Türkiye

Sivas Cumhuriyet University



### DIGITAL DIPLOMACY AND ITS IMPACT ON INTERNATIONAL RELATIONS: THE POWER OF DIGITAL TRANSFORMATION TO DIRECT CLIMATE AND ENVIRONMENTAL POLICIES

**Pınar Buket Kılınc Pala**

Dr. Öğretim Üyesi Dumlupınar Üniversitesi, Siyaset Bilimi ve Uluslararası İlişkiler Bölümü, Kütahya- Türkiye  
ORCID: 0000-0002-7434-4098

#### ABSTRACT

The act of planning in international relations is a global security priority in a close-knit world. Finally, popular distribution digital diplomacy makes it possible for public diplomacy departments to be in direct and constant communication with various representatives. The adoption of social media for diplomatic activities is not limited to just those being hosted but also includes communication. The first part of this article involves exploring the disruption of digital diplomacy and analyzing the personalities on international relations and examining the general trend of global actors. The other touches upon the distinction between digital diplomacy and other related concepts, public diplomacy and media diplomacy, through a critical review in general terms. Evolving operational operations has the potential to fundamentally change the way states and their day-to-day operations operate. Providing connections between individuals to enable developments of cooperation, trade and information sharing. Its second purpose is to discuss and distribute the contribution of all these developments to climate diplomacy and energy diplomacy efforts. The potential of digital diplomacy to combat climate conditions, increase range and support the determination of sustainable development is examined. The research method is to report and examine active policies that spread the digital diplomacy on climate and environment. Additionally, the study system includes a literature review. As a result of the study, the power to actively shape a fair and sustainable global future through climate diplomacy from the digital environment is limited, but it is possible to make progress in this field in the future.

**Keywords:** Digital diplomacy, energy policy, climate policy, diplomacy



### EFFECT OF COVID-19 AND GLOBAL ENERGY CRISIS ON ELECTRICITY PRICES

**Başak İrem Öztürk**

Bahcesehir University, Faculty of Economics Administrative and Social Sciences, Department of International Finance, Istanbul-Türkiye, (Responsible Author) ORCID: 0009-0000-8264-8094

**Umut Uğurlu**

Dr. Öğr. Üyesi, Bahcesehir University, Faculty of Economics Administrative and Social Sciences, Department of International Finance, Istanbul-Türkiye, ORCID: 0000-0002-6183-969X

#### ABSTRACT

Electricity is an asset that shows seasonality behaviour, but this behaviour undergone a change by series of significant events which occurred globally such as Covid-19 Pandemic and Global Energy Crisis. An example of the highlighted change might be that regarding monthly seasonality behaviour of the prices, a decrease in spring especially in March is expected as it is observed in our preliminary study between 2016 to 2021, however in 2022 this behaviour changed by a continuous increase from February to March. Although lockdowns reduced electricity prices early on Covid-19 periods it caused price hikes in 2021 and 2022 together with ongoing Global Energy Crisis. In this regard, preliminary results showed that prices decreased by 70.78% from March 2020 to April 2020. On the other hand, we observed 172.24% increase in April 2021 compared to the same month of 2020. Economically speaking, increases in annual inflation observed from CPI and PPI indexes of Turkey, depreciation of Turkish Lira against foreign currencies, especially Euro and Dollar, in recent periods and increasing trading price of Brent crude oil supported highlighted electricity price increases. Moreover, energy production from imports of fossil fuels such as petroleum and natural gas have left their place to energy production from renewable energy between 2021-2023 to decrease the current account deficit share originated from energy production of importing fossil fuel. In that sense, remarkable investments of renewable energy are observed especially in Turkey. Consequently, electricity prices are influenced by many events that occurred in different industries such as health and energy from past to today, specifically latest events played an important role in sharp rises of electricity prices in years between 2020-2023.

**Keywords:** Electricity Prices, Covid-19 Pandemic, Global Energy Crisis, Renewable Energy, Energy Production



### SERA GAZI EMİSYONUNUN KALKINMA EKONOMİSİ AÇISINDAN, NEDENSELLİK ANALİZİ İLE İNCELENMESİ: TÜRKİYE ÖRNEĞİ

**Serdar ERDOĞAN**

Dr.Öğr.Üyesi, Trakya Üniversitesi Uzunköprü Uygulamalı Bilimler Yüksekokulu, İktisat Anabilim Dalı, Edirne-Türkiye,  
ORCID:0000-0001-8594-3929

#### ÖZET

Doğa ve çevre koşullarının kaliteli hale gelmesi yaşam standartlarını da yükseltmekte ve insan odaklı kalkınma açısından büyük önem arz etmektedir. Bu çalışmada sera gazı emisyonunun Türkiye'deki bazı seçilmiş kalkınma ekonomisine yönelik değişkenlerle arasındaki korelasyon ve nedensellik ilişkisine yönelik bir inceleme yapılmaktadır. Bu çalışmada 1990-2021 yılları arası için Türkiye'ye yönelik Sera gazı emisyonu, beklenen yaşam süresi, ekonomik büyüme, yenilenebilir enerji tüketimi ve doğrudan yabancı yatırımlar verileri ile korelasyon ve nedensellik analizi yöntemleri uygulanmıştır.

Sera gazı emisyonu ile beklenen yaşam süresi ve yenilenebilir enerji tüketim arasında güçlü bir ilişki bulunduğu tespit edilmiştir. Söz konusu ilişkinin beklenen yaşam süresi ile pozitif yönlü olduğu fakat yenilenebilir enerji ile negatif yönlü olduğu görülmüştür. Bunun dışında sera gazı emisyonuyla doğrudan yabancı yatırımlar arasında pozitif yönlü ve orta düzeyde bir ilişki bulunmuştur.

Nedensellik analizi testlerinden Granger nedensellik testi sonuçlarına göre sera gazı emisyonu ile beklenen yaşam süresi arasında karşılıklı nedensellik ilişkisinin anlamlı olduğu tespit edilmiştir. Ayrıca Sera gazı emisyonundan doğrudan yabancı yatırımların nedeni olduğu bulunmuştur. Wald testi itibarıyla ise Yenilenebilir enerji tüketimi ile sera gazı emisyonu arasında karşılıklı nedensellik ilişkisi tespit edilmiştir. Ayrıca Doğrudan yabancı yatırımlar ve beklenen yaşam süresi değişkenlerinden sera gazı emisyonuna doğru tek yönlü nedensellik ilişkisinin anlamlı olduğu bulunmuştur.

**Anahtar Kelimeler:** Sera Gazı Emisyonu, Kalkınma Ekonomisi, Nedensellik, Türkiye

#### INVESTIGATION OF GREENHOUSE GAS EMISSION WITH CAUSALITY ANALYSIS IN TERMS OF DEVELOPMENT ECONOMICS: THE CASE OF TURKEY

#### ABSTRACT

Improving the quality of nature and environmental conditions raises living standards and is of great importance in terms of human-oriented development. This study analyses the correlation and causality relationship between GHG emissions and some selected development economics variables in Türkiye. In this study, correlation and causality analysis methods were applied with the data on GHG emissions, life expectancy, economic growth, renewable energy consumption and foreign direct investments for Türkiye with the period 1990-2021.

It is found that there is a strong relationship between greenhouse gas emissions and life expectancy and renewable energy consumption. This relationship is positively correlated with life expectancy but negatively correlated with renewable energy. In addition, a positive and moderate relationship was found between greenhouse gas emissions and foreign direct investments.

According to the results of the Granger causality test, which is one of the causality analysis tests, it was found that the mutual causality relationship between greenhouse gas emission and life expectancy is significant. In addition, it was found that greenhouse gas emission is the cause of foreign direct investment. According to the Wald test, a mutual causality relationship was found between renewable energy consumption and greenhouse

gas emissions. In addition, FDI and life expectancy variables are found to be the cause of greenhouse gas emissions.

**Keywords:** Greenhouse Gas Emissions, Development Economics, Causality, Türkiye

## Giriş

Doğal çevrenin yaşanabilir nitelikte olması insan hayatının sürdürülebilirliğini sağlamakla birlikte gelecek nesillerin kaliteli bir hayat standardını yakalamasında büyük önem taşımaktadır. Artan nüfusla birlikte insan ihtiyaçlarının giderek çoğalmasına karşılık doğadaki kıt kaynakların giderek azalması insanoğlunu yeni arayışlara itmektedir. Bu arayışlar sırasında insanoğlunun bazı faaliyetleri özellikle çevre koşullarına ciddi zararlar verebilmektedir. Bu da söz konusu ülkelerin kalkınma problemini beraberinde getirmektedir. Çünkü ekonomik kalkınma ekonomik büyümeden farklı olarak sosyoekonomik ve çevresel şartların bir ülkede nitelik bakımından değişimini de içinde barındırmaktadır.

Sera gazları, ormanların tahrip edilmesi, fosil yakıtların yanması, tarımsal faaliyetler ve enerji kullanımının yol açtığı karbondioksit vs. gazlarının atmosferde çoğalması sonucu küresel ısınma ve iklimsel değişimlere yol açan bir sürecin temel kaynağıdır. Enerji tüketiminin artması sera gazı emisyonunu arttırırken, bu noktada yenilenebilir enerji kaynaklarının bulunmasıyla artan enerji üretimi sera gazı emisyonunun düşmesinde büyük rol oynamıştır (Erdoğan, 2020).

Küresel ısınma sonucu meydana gelen iklim değişikliklerini ortaya çıkaran sera gazlarını düşürmek amacıyla Kyoto Protokolü tarafından 3 temel mekanizma geliştirilmiştir. Bunlar; Temiz kalkınma mekanizması, ortak yürütme mekanizması ve emisyon ticaretidir. Bu mekanizmaların ilki olan kalkınma temelli mekanizmaya göre, az gelişmiş ülkelere yönelik söz konusu protokol çerçevesinde düşük emisyon hedefine yönelik proje bazlı yatırımlar teşvik edilecektir. Bu yatırımlar sayesinde söz konusu ülkeler gelişen teknolojiye ve ciddi oranda yabancı yatırımı da ülkesine kazandırmış olacaklardır (Mercan ve Karakaya, 2013). Burada özellikle çalışmada kullanılan kalkınma değişkenlerinden yenilenebilir enerji tüketimi ve yabancı yatırımlar ile sera gazı emisyonu arasında korelasyon ve nedensellik ilişkisinin ne yönde olacağı ve iktisadi olarak beklentileri ne ölçüde sağlayacağı merak konusudur.

Bu çalışmada sera gazı emisyonu ile bazı gelişmişlik göstergeleri olan sosyoekonomik değişkenler ile arasındaki ilişkilerin incelenmesi amaçlanmaktadır. Burada kalkınmayı temsilen, ekonomik büyüme, yabancı yatırımlar, beklenen yaşam süresi ve yenilenebilir enerji tüketimi değişkenleri kullanılmaktadır. Söz konusu çalışmada 1990-2021 arası dönem için Türkiye'ye yönelik veriler kullanılmış olup, korelasyon ve nedensellik analizleri ile çalışmanın ampirik kısmı yapılmaktadır. Aşağıdaki tabloda sera gazı emisyonunun ekonomik değişkenler ile arasındaki ilişkiyi açıklamaya yönelik literatür özeti verilmektedir.

**Tablo.1:** Literatür Özeti

Yazar/Yazarlar	Ülke ve Dönem	Yöntem	Sonuç
Halıcıoğlu, 2009	Türkiye, 1960-2005	Granger Nedensellik analizi ve Bounds Testi	Tüketim, gelir ve yabancı yatırımların uzun dönemde karbon emisyonunun önemli belirleyicileri olduğu tespit edilmiştir.
Çınar, 2011	OECD Ülkeleri, 1971-2007	Panel Birim Kök ve Eş-bütünleşme	Gelir ve Sera Gazı arasında uzun dönemli anlamlı ve pozitif yönlü ilişki bulunmuştur.
Tutulmaz vd., 2012	45 Ülke, 1971-2011	Panel Veri Uygulaması	Çevresel Kuznets eğrisi hipotezinin kısa dönemde geçerli olduğu tespit edilmiştir.
Dam, 2014	OECD Ülkeleri, 1971-2011	Panel Veri Analizi	Enerji tüketimi, ekonomik büyüme, ihracat, ithalat ve kişi başı gelir değişkenlerinin sera gazı üzerinde etkili olduğu sonuçları elde edilmiştir.
Kapusuzoğlu, 2014	OECD Ülkeleri, 1960-2008	Granger Nedensellik ve VAR modeli	Karbon emisyonundan milli gelire doğru tek yönlü nedensellik ilişkisinin Türkiye ve dünya

				genelinde geçerli olduğu bulunmuştur.
<b>Atay Polat, 2015</b>	Türkiye, 1980-2013	Yapısal Kırılmalı eşbütünleşme Testleri		Enerji tüketimi, GSYH ve yabancı yatırımlar ile karbon emisyonu arasında uzun dönemli anlamlı ilişkiler tespit edilmiştir.
<b>Ceylan ve Karaağaç, 2020</b>	Türkiye, 1960-2014	Kırılmalı eş-bütünleşme ve Hata Düzeltme Modeli		Ekonomik büyümenin çevresel kirlilik üzerinde etkili olduğu fakat Çevresel Kuznets eğrisinin Türkiye için geçerli olmadığı tespit edilmiştir.
<b>Sumerli Sarıgül ve Altay Topçu, 2021</b>	Türkiye, 1994-2015	Johansen Analizi	Ko-entegrasyon	Vergilerin uzun dönemde karbon emisyonunu düşürücü etkisi tespit edilmiştir.
<b>Doğanlar vd., 2021</b>	Türkiye, 1965-2018	RALS-EG yöntemi	Eş-bütünleşme	Uzun dönemde ekonomik büyüme, enerji tüketimi ve finansal kalkınma ile karbon emisyonu arasında anlamlı ilişkiler bulunmuştur.

Yukarıdaki tabloda sera gazının çeşitli ekonomik değişkenler ile arasındaki ilişkiyi açıklamaya yönelik gerek Türkiye'ye gerekse çeşitli ülke gruplarına yönelik çalışmalara yer verilmiştir.

### Materyaller ve Yöntem

Çalışmada öncelikli olarak kullanılan değişkenlere ait açıklama yapılacaktır. Sonrasında ise çalışmada uygulanacak olan yönteme geçilecektir. Burada öncelikli olarak korelasyon ilişkisine bakılıp ardında 2 farklı nedensellik testi ile sera gazı emisyonu ile seçili ekonomik kalkınma göstergeleri ile olan ilişkiye bakılacaktır.

İktisadi uygulamalara yönelik yapılmış olan çalışmalarda değişkenler arasındaki ilişkinin yönü ve büyüklüğü hakkında bilgi vermek için standart ölçü birimi olmayan kovaryanstan sağlanan standart ölçü birimi halini alan korelasyon katsayısının yorumlanmasına yönelik analizdir (Gürüş ve Çağlayan, 2000).

Ekonometri temelli iktisadi analizli çalışmalarda çeşitli iktisadi değişkenler arasındaki neden sonuç ilişkisinin yönünün bulunmasında Granger (1969) öncülüğünde geliştirilmiş olan nedensellik testleri kullanılmaktadır.

Bu analiz aşağıdaki denklemler ile gösterilirse;

$$B_t = \sum_{i=1}^n \alpha_i B_{t-i} + \sum_{i=1}^n \partial_i YB_{t-i} + e_{1t} \quad (1)$$

$$YB_t = \sum_{i=1}^n \alpha_i YB_{t-i} + \sum_{i=1}^n \partial_i B_{t-i} + e_{2t} \quad (2)$$

Yukardaki matematiksel denklemlere göre, tek yönlü nedensellik ilişkisinde katsayılarından sadece denklemdaki  $\partial_i$  katsayısı anlamlı iken, karşılıklı iki yönlü nedensellik ilişkisinin tespitinde ise denklemlerdeki  $\alpha_i$  ve  $\partial_i$  katsayıların her ikisinin de anlamlılığı söz konusudur (Kutlar, 2009).

Aşağıda tablo 2'de bu çalışmada kullanılan değişkenler açıklamalarına yer verilmiş olup elde edildikleri kaynaklar hakkında bilgi sunulmaktadır.

**Tablo 2: Değişkenlerin Açıklanması**

Dönem Aralığı: 1990 – 2021		Kaynak
Değişkenler	Açıklama	
<b><i>SGE<sub>t</sub></i></b>	Sera Gazı Emisyonu	Worldbank (2023a)
<b><i>DYYG<sub>t</sub></i></b>	Doğrudan Yabancı Yatırım Milli Gelir Oranı	Worldbank (2023b)
<b><i>MGB<sub>t</sub></i></b>	Ekonomik Büyüme	Worldbank (2023c)
<b><i>BYS<sub>t</sub></i></b>	Beklenen Yaşam Süresi	Worldbank (2023d)
<b><i>YET<sub>t</sub></i></b>	Yenilenebilir Enerji Tüketimi	Worldbank (2023e)



Yukarıdaki tabloda çalışmada yer alan değişkenlerin açıklamaları yapılmıştır. Burada ise söz konusu değişkenlerin kullanılmış olduğu korelasyon ve nedensellik analizi yöntemleri sonucunda elde edilen bulgular değerlendirilecektir.

### Bulgular ve Tartışma

Sera gazı emisyonunun kalkınma ekonomisi çerçevesinde ele alınmasına yönelik yapılan bu çalışmada sırasıyla korelasyon ve nedensellik analizi uygulanmaktadır.

Aşağıdaki korelasyon matrisi tablosunda çalışmada bulunan değişkenler arasındaki korelasyon ilişkisinden elde edilen sonuçlar verilmiştir.

**Tablo 3: Korelasyon Matrisi**

Korelasyon	$DYYG_t$	$MGB_t$	$BYS_t$	$YET_t$
$SGE_t$	0.518	0.118	0.945	-0.852

Yukarıdaki korelasyon matrisi sonuçlarına göre, sera gazı emisyonu ile en güçlü ilişkiye sahip olan değişken doğru yönlü olup beklenen yaşam süresidir. Ayrıca yenilenebilir enerji tüketimi ile sera gazı arasındaki ilişki ise güçlü ve ter yönlüdür. Bunun yanında doğrudan yabancı yatırımlar ile sera gazı emisyonu arasındaki ilişki ise doğru yönlü ve orta düzeydedir. Milli gelir ve sera gazı emisyonu arasındaki ilişkinin ise düşük düzeyde olduğu görülmüştür.

Aşağıdaki tabloda öncelikli olarak nedensellik testlerinin gecikme katsayısının belirlenmesine yönelik bilgi kriterleri verilmiştir.

**Tablo 4: Gecikme Katsayısının Belirlenmesi**

İçsel Değişkenler: $SGE_t$ , $DYYG_t$ , $MGB_t$ , $BYS_t$ , $YET_t$				Dışsal Değişken: C		
Gözlem Sayısı: 30				Gecikme: 2		
Lag	LogL	LR	FPE	AIC	SC	HQ
0	-386.6113	NA	149965.4	26.10742	26.34095	26.18213
1	-263.7946	196.5068	226.8400	19.58630	20.98750*	20.03456
2	-231.0774	41.44171*	157.8179*	19.07183*	21.64069	19.89363*

\*Nedensellik Testleri Gecikme Kriterleri; HQ:Hannan-Quinn Bilgi Kriteri, SC: Schwarz Bilgi Kriteri, AIC: Akaike Bilgi Kriteri, FPE: Final prediction error, LR: sequential modified LR test statistic (each test at 5% level)

Yukarıdaki tabloya göre nedensellik testlerindeki gecikme katsayısının 2 olduğu tespit edilmiştir. Aşağıda ise nedensellik testleri sonuçları verilmiştir.

**Tablo 5: Nedensellik Testi Sonuçları**

Pairwise Granger Nedensellik Testi			
Dönem: 1990 – 2021	Gözlem Sayısı: 30	Gecikme: 2	
Hipotez	Sonuç	F-İstatistik	Olasılık
Sera Gazı Emisyonu Doğrudan Yabancı Yatırımların	Nedenidir	4.26377	0.0255
Doğrudan Yabancı Yatırımlar Sera Gazı Emisyonunun	Nedeni Değildir	0.69298	0.5094
Sera Gazı Emisyonu Ekonomik Büyümenin	Nedeni Değildir	0.40782	0.6694
Ekonomik Büyüme Sera Gazı Emisyonunun	Nedeni Değildir	0.31811	0.7304
Sera Gazı Emisyonu Beklenen Yaşam Süresinin	Nedenidir	2.76031	0.0826
Beklenen Yaşam Süresi Sera Gazı Emisyonunun	Nedenidir	13.9961	8.E-05
Sera Gazı Emisyonu Yenilenebilir Enerji Tüketiminin	Nedeni Değildir	0.64358	0.5339

Yenilenebilir Enerji Tüketimi Sera Gazı Emisyonunun		Nedeni Değildir	0.82450	0.4500
VAR Granger Causality/Block Exogeneity Wald Tests				
Dönem: 1990 – 2021		Gözlem Sayısı: 30	Gecikme: 2	
Hipotez	Sonuç	F-İstatistik	Olasılık	
Sera Gazı Emisyonu Doğrudan Yabancı Yatırımların	Nedeni Değildir	1,756	0,415	
<b>Doğrudan Yabancı Yatırımlar Sera Gazı Emisyonunun</b>	<b>Nedenidir</b>	<b>5,437</b>	<b>0,065</b>	
Sera Gazı Emisyonu Ekonomik Büyümenin	Nedeni Değildir	3,890	0,142	
Ekonomik Büyüme Sera Gazı Emisyonunun	Nedeni Değildir	3,064	0,216	
Sera Gazı Emisyonu Beklenen Yaşam Süresinin	Nedeni Değildir	0,987	0,614	
<b>Beklenen Yaşam Süresi Sera Gazı Emisyonunun</b>	<b>Nedenidir</b>	<b>32,875</b>	<b>0,000</b>	
<b>Sera Gazı Emisyonu Yenilenebilir Enerji Tüketiminin</b>	<b>Nedenidir</b>	<b>8,191</b>	<b>0,016</b>	
<b>Yenilenebilir Enerji Tüketimi Sera Gazı Emisyonunun</b>	<b>Nedenidir</b>	<b>8,347</b>	<b>0,015</b>	

Yukardaki nedensellik testleri sonuçlarına göre, Granger nedensellik testi bağlamında beklenen yaşam süresi ile sera gazı emisyonu arasında karşılıklı iki yönlü nedenselliğin anlamlı olduğu tespit edilmiştir. Ayrıca sera gazı emisyonundan doğrudan yabancı yatırımlara doğru tek yönlü nedensellik ilişkisinin anlamlı olduğu bulunmuştur.

VAR nedensellik testine göre ise, yenilenebilir enerji tüketimi ile sera gazı emisyonu arasında karşılıklı çift yönlü nedenselliğin anlamlı olduğu görülmüştür. Ayrıca doğrudan yabancı yatırımlardan ve beklenen yaşam süresinden sera gazı emisyonuna doğru tek yönlü nedensellik ilişkisinin anlamlı olduğu sonucuna ulaşılmıştır. Bu da söz konusu çalışmada beklenen yaşam süresi ve yenilenebilir enerji tüketimi sera gazı emisyonu ile istatistiksel açıdan en anlamlı ilişkiye sahip olduğu değişkenler olduğunu ortaya koymuştur.

### Sonuç ve Öneriler

İnsanoğlunun temiz çevre koşullarında hayatını sürdürmeye sahip olması en önemli kalkınmışlık göstergelerinden birisidir. Çünkü doğal çevredeki kötü koşullar insan hayatının yaşam süresini kısaltmakla birlikte yaşadığı süreç boyunca da sağlık problemlerinin ortaya çıkması kaçınılmazdır. Bu noktada kimi devletler kendi ülke sınırları içinde yaşayan halkının hayat standartlarını geliştirmek için başka ülke kaynaklarını kendi çıkarları doğrultusunda kullanarak diğer ülkelerin yaşam koşullarını kötüleştirmeden gerçekleştirebilmeleri büyük önem taşımaktadır. İşte tüm problem bu minvalde gerçekleşmekte olup yabancı yatırımcılar yatırım yaptıkları ülkenin kaynaklarını o bölge insanlarını olumsuz etkilemeyecek şekilde kullanmaları çok büyük önem taşımaktadır.

Bu çalışmada elde edilen sonuçlara bakıldığında korelasyon analizi açısından sera gazı emisyonu ile beklenen yaşam süresi ve yenilenebilir enerji tüketimi arasında güçlü bir ilişki bulunduğu tespit edilmiştir. Bu ilişkinin yönünün beklenen yaşam süresi ile pozitif yönlü fakat yenilenebilir enerji tüketimi ile negatif yönlü olduğu tespit edilmiştir. Nedensellik testi açısından bakıldığında ise, kullanılan iki testten birinde beklenen yaşam süresi ve yenilenebilir enerji tüketimi ile sera gazı emisyonunun çift yönlü nedensellik ilişkisine sahip olduğu görülmüştür. Ayrıca doğrudan yabancı yatırımlar ile sera gazı emisyonu arasında tek yönlü nedensellik ilişkisine sahip oldukları görülmüştür. Fakat ekonomik büyüme ile sera gazı emisyonu arasında nedensellik ilişkisine yönelik anlamlı bir sonuç bulunamamıştır.

Çalışmada elde edilen sonuçlar bağlamında sera gazı emisyonunun düşürülerek ülke halklarının daha sağlıklı ve gelişmiş bir yaşam sürdürmelerinde devletlerin izleyeceği kalkınma ve çevre politikaları büyük önem taşımaktadır. Halkın gelir düzeyinin ve sağlıklı yaşam süresinin artırılmasında doğrudan yabancı yatırımların teşvik edilmesinin ve yenilenebilir enerji kaynaklarının kullanımının etkisi göz ardı edilmemelidir. Sonuç olarak sera gazı emisyonunun düşürülmesinde firmaların üretim koşullarının iyileştirilmesi ve söz konusu üretim yöntemlerinin Kyoto Protokolü çerçevesinde çevre politikalarıyla uyumlu ve uluslararası standartlardan sapmadan koordine şekilde sürdürülebilirliği büyük önem arz etmektedir.

**Teşekkürler ve Bilgi Notu**

Cumhuriyetimizin 100. Yılında 26-27 Eylül 2023 tarihlerinde düzenlenen bu kongrede başta Sivas Cumhuriyet Üniversitesi'nin tüm çalışanlarına, meslektaşlarıma ve sayın hocalarıma göstermiş oldukları ilgiye ve kongrede emeği geçen herkese teşekkürlerimi sunarım. Bir başka kongrede görüşmek dileğiyle saygılarımla, iyi çalışmalar dilerim.

**Kaynaklar**

Ceylan, R., & Karaağaç, G. E. (2020). Türkiye'de Çevresel Kuznets Eğrisi hipotezinin test edilmesi: Yapısal kırılmalı eşbütünleşme testi ile hata düzeltme modelinden kanıtlar. *Pamukkale Journal of Eurasian Socioeconomic Studies*, 7(2), 75-85.

Çınar, S. (2011). Gelir ve CO2 emisyonu ilişkisi: panel birim kök ve eşbütünleşme testi. *Uludağ Üniversitesi İktisadi ve İdari Bilimler Fakültesi Dergisi*, 30(2), 71-83.

Dam, M. M. (2014). *Sera gazı emisyonlarının makroekonomik değişkenlerle ilişkisi: OECD ülkeleri için panel veri analizi*, Doktora Tezi, Adnan Menderes Üniversitesi, Aydın.

Doğanlar, M., Mike, F., Kızılkaya, O., & Karlılar, S. (2021). Testing the long-run effects of economic growth, financial development and energy consumption on CO2 emissions in Turkey: new evidence from RALS cointegration test. *Environmental Science and Pollution Research*, 28(25), 32554-32563.

Erdoğan, S. (2020). Enerji, çevre ve sera gazları. *Çankırı Karatekin Üniversitesi İİBF Dergisi*, 10 (1), 277-303.

Granger, C. W. J., (1969). Investigating causal relations by econometric models and cross-spectral methods, *Econometrica*, 37, 424-438.

Güriş, S. & Çağlayan, E. (2000). *Ekonometri Temel Kavramlar*. 1.B., Der Yayınevi, İstanbul.

Halıcıoğlu, F. (2009). An econometric study of CO2 emissions, energy consumption, income and foreign trade in Turkey. *Energy policy*, 37(3), 1156-1164.

Kapusuzoğlu, A. (2014). Causality Relationships between Carbon Dioxide Emissions and Economic Growth: Results from a Multi-Country Study. *International Journal of Economic Perspectives*, 8(2), 5-15.

Kutlar, A. (2009). *Uygulamalı Ekonometri*. Nobel Yayın Dağıtım: Ankara.

Mercan, M., & Karakaya, E. (2013). Sera Gazı Salımının Azaltımında Alternatif Politikaların Ekonomik Maliyetlerinin İncelenmesi: Türkiye İçin Genel Denge Analizi. *Erciyes Üniversitesi İktisadi ve İdari Bilimler Fakültesi Dergisi*, (42), 123-159.

Polat, M. A. (2015). Türkiye'de Yabancı Sermaye Yatırımları ile CO2 Emisyonu Arasındaki İlişkinin Yapısal Kırılmalı Testler ile Analizi. *Journal of International Social Research*, 8(41). 1127-1135.

Sarıgül, S. S., & Topcu, B. A. (2021). The impact of environmental taxes on carbon dioxide emissions in Turkey. *International Journal of Business and Economic Studies*, 3(1), 43-54.

Tutulmaz, O., Şahinöz, A., & Çağatay, S. (2012). Karbondioksit emisyonu üzerinden çevre baskısı değerlendirilmesi: Çevresel Kuznets eğrisine panel veri uygulaması. *İktisat İşletme ve Finans*, 27(314), 35-72.

Worldbank,(2023a). <https://data.worldbank.org.cn/indicator/EN.ATM.GHGT.ZG?view=chart>, Erişim Tarihi: 10.06.2023

Worldbank,(2023b).<https://data.worldbank.org/indicator/BX.KLT.DINV.CD.WD?view=chart>, Erişim Tarihi: 10.06.2023

Worldbank,(2023c).<https://data.worldbank.org/indicator/NY.GDP.MKTP.KD.ZG?view=chart>, Erişim Tarihi: 10.06.2023

Worldbank, (2023d). <https://data.worldbank.org.cn/indicator/SP.DYN.LE00.IN?view=chart>, Erişim Tarihi: 10.06.2023

Worldbank, (2023e). <https://data.worldbank.org/indicator/EG.FEC.RNEW.ZS?view=chart>, Eriřim Tarihi: 10.06.2023



**IMPACT OF DYNAMIC COD LOADING PROFILES ON BIOENERGY GENERATION AND  
SIMULTANEOUS WASTEWATER TREATMENT IN MICROBIAL FUEL CELLS**

**Aliyu Ishaq<sup>1,2</sup>, Mohd Ismid Mohd Said<sup>1</sup>, Shamila. Binti Azman<sup>1</sup>, Shamsudeen Mohammed Jumande<sup>2</sup>,  
Al-Amin Danladi Bello<sup>2</sup>.**

<sup>1</sup>Department of Water and Environmental Engineering, School of Civil Engineering, Faculty of Engineering, Universiti Teknologi Malaysia, 81300 Johr Bohr, Malaysia.

<sup>2</sup>Department of Water Resources and Environmental Engineering, Ahmadu Bello University, 1045, Zaria, Kaduna Nigeria.

**ABSTRACT**

Sustainable energy generation and environmental remediation are both possible through the synergistic interaction of microbial fuel cells (MFCs), bioenergy recovery, and concurrent wastewater treatment. Environmental and economic sustainability should be considered to find an effective treatment technique for low- to middle-income countries. This research examines the complex interplay between chemical oxygen demand (COD) concentrations and the performance of dual-chamber microbial fuel cells (DMFCs) for the generation of bioenergy and leachate wastewater treatment. The microbial activity was identified by calculating how long it would take for bacterial populations to stabilize using the optical density (OD) 600nm technique of growth kinetics analysis. The structural adaptations of the microbial population to varying COD levels were also elucidated by analyzing biofilm growth on the anode using field emission scanning electron microscopy (FE-SEM). Treatment effectiveness was measured for both NH<sub>4</sub>-N and COD removal.

Seven various concentrations of COD, from 1325 mg L<sup>-1</sup> to 500 mg L<sup>-1</sup>, were studied. The complicated relationship between COD levels and energy recovery potential is reflected in the wide range of power densities corresponding to these COD concentrations, from 161.45 mW/m<sup>3</sup> to 339.41 mW/m<sup>3</sup>. Throughout the experiments, the temperature was kept at 30 degrees Celsius, the pH was kept at 6.88, and the NH<sub>4</sub>-N concentration was kept at 800 mg L<sup>-1</sup>. At 3325 mg L<sup>-1</sup> (339.41 mW/m<sup>3</sup>), the highest power density was recorded. Microbial growth and activity increased throughout time, reaching a peak at an OD value of 0.8 after the ensuing 6-hour period. This is evidence of a dramatic increase in the number of microorganisms in the environment. This elucidates their potential as bioenergy sources and wastewater treatment systems by demonstrating the complex dynamics of MFCs under varying COD concentrations.

**Keywords:** Microbial fuel cells, COD, microbial growth kinetics.



---

EVALUATION OF GARLIC EXTRACT AS A NATURAL ANTIOXIDANT FOR J. CURCAS  
BIODIESEL STABILITY

---

M. Mamuda<sup>1</sup>, I. A. Khalil<sup>2</sup> and A. M. Sokoto<sup>3</sup>

<sup>1</sup>Department of Mechanical Engineering, Usmanu Danfodiyo University Sokoto, Nigeria

<sup>2</sup>Department of Pure and Applied Chemistry, Usmanu Danfodiyo University Sokoto, Nigeria

<sup>3</sup>Sultan Muhammadu Maccido Institute for Qur'an and General Studies Sokoto, Nigeria

### ABSTRACT

Environmentally friendly source of energy gives biodiesel lead over fossil fuels, Oxidation is one of the impediments to the biodiesel quality, the greater the oxidation the lesser the quality of the biodiesel and vice versa. Synthetic antioxidants are commonly used to improve biodiesel stability regrettably they have damaging effect on the environment. This study explores the effectiveness of garlic extract as natural antioxidants for *Jatropha curcas* biodiesel stability. The garlic extract was characterized using FTIR and GC-MS and the fuel parameters of the produced biodiesel were determined. The garlic extracts were added were added in 1%, 3% and 5% respectively to the biodiesel samples and the oxidation stability test of the biodiesel samples were carried out using Rancimat method. The FTIR and GC-MS result of the extract confirmed the existence of phenolic and sulphur compounds. The fuel parameters of the biodiesel produced were in agreement with ASTM standard values. A rise in Induction period of the biodiesel was observed in samples BG3 and BG5 having 3% and 5% antioxidants respectively. The results demonstrates that the antioxidant (garlic extract) can improve induction period of the biodiesel hence can act as natural antioxidant on biodiesel samples.

**Keywords:** *Jatropha curcas*, Oxidation stability, Biodiesel, Fossil fuel, FTIR and GC-MS.



## CATALYTIC ESTERIFICATION OF BIODIESEL USING MESOPOROUS MATERIAL

**Boughedir nadia<sup>1,2</sup>, Bailliche Zohra<sup>1,2</sup>**

<sup>1</sup> Université de Tlemcen BP 119 Laboratoire de Catalyse et Synthèse en Chimie Organique, Algérie

<sup>2</sup> université de Ain t émouchent laboratoire de chimie ;Algérie

### ABSTRACT

The biodiesel or diester sector uses the constituents of fatty substances present in vegetable oils as fuel. Vegetable oils are treated to provide vegetable oil methyl esters (VOME) whose combustion characteristics are close to fuel oil. The vegetable oils mainly used as raw materials are in Europe: sunflower soy rapeseed oil. Biofuels are incorporated from 5% to 30% in fuel oil for use in diesel engines.

Esters formed by esyerification of fatty acids are used in cosmetics, in pharmaceuticals, in industrial lubricants This type of reaction corresponds to an equilibrium: reaction occurring in both directions and limiting each other .

Ag/SBA-15 is a hybrid material composed of silver nanoparticles (Ag) supported on SBA-15, a mesoporous silica with a high surface area and tunable pore size. This catalyst has been widely studied for its potential applications in various fields, including catalysis, sensing, and drug delivery

We synthesized our catalyst by diffrent methodes ( direct synthesis and post synthesis)

we tested our synthesized materials as catalysts in esterification reactions of fatty acids which is a natural molecule. and characterize by DRX ; FTIR

**key words:** Ag/SBA15; esterification ;fatty acids ;biodiesel;



**HYDROTHERMAL GASIFICATION OF SELECTED FOODS FOR SUSTAINABLE ENERGY GENERATION USING ASPEN PLUS**

**Isaac Jato<sup>1,2</sup>, Kabir Garba<sup>2</sup>, Maryam Ibrahim<sup>2</sup>, Ahmed Mohammed Inuwa<sup>2</sup>, Faizah Idris Sallau<sup>2</sup>, Sagir Umar<sup>2</sup>, Habibu Abubakar Waniyo<sup>2,3</sup>**

<sup>1</sup>Department of Science Laboratory Technology, Federal Polytechnic N'yak Shendam 940103, Plateau, Nigeria

<sup>2</sup>Department of Chemical Engineering, Abubakar Tafawa Balewa University 740272, Bauchi, Nigeria

<sup>3</sup>Department of Chemical Engineering, Federal Polytechnic Kaltungo P.M.B 009, Gombe, Nigeria

**ABSTRACT**

Fossil fuels are becoming scarce and depleting at an alarming rate. To address the ever-increasing energy demand and the worrying deterioration of the climatic condition, researchers are obligated to pursue alternate feedstock for sustainable energy generation that promotes carbon neutrality. The search leads to lignocellulosic materials like unprocessed food wastes. These are sizing quantities of agro-waste that seem promising for the production of bioenergy, especially in tropical and subtropical countries. This study has harness the chunk of food wastes accrued in the food markets and industries basically banana, orange, water melon and mango endocarp biomass. This has been achieved by sourcing the food wastes data to obtain their proximate and ultimate analyses values. The sensitivity analysis was carried out around the gasifier via checking the effect of the reactors temperature on the syngas yield and power generation, the total of 100 kg/h of waste fruit biomass was feed to each system combining 25 % each for banana peel, water melon, orange peel and mango endocarp. The yield of CH<sub>4</sub> maintains at a relatively low level when gasification temperature is above 800 °C. When gasification temperature is around 1000 °C, the volume fraction of H<sub>2</sub> reaches the maximum. Finally, it was detected that temperature has effect on power generation.

**Keywords:** Hydrothermal Gasification, Pyrolysis, Food Waste, Energy and Treatment.





A REVIEW ON BIO-OIL PRODUCTION AND UPGRADING USING ZEOLITE CATALYST

Isaac JATO<sup>1,2</sup>, Ahmed Mohammed INUWA<sup>2</sup>, Habibu Abubakar WANIYO<sup>2,3</sup> Faizah Idris Sallau<sup>2</sup>

<sup>1</sup>Department of Science Laboratory Technology, Federal Polytechnic N'yak Shendam, Plateau, Nigeria

<sup>2</sup>Department of Chemical Engineering, Abubakar Tafawa Balewa University P.M.B 0247, Bauchi, Nigeria

<sup>3</sup>Department of Chemical Engineering, Federal Polytechnic Kaltungo P.M.B 009, Gombe, Nigeria

**ABSTRACT**

Due to concerns about energy security in the near future and environmental issues related to the usage of petroleum-based fuels, the development of an alternative fuel that would lessen dependence on fossil fuels has gained interest recently. One source of renewable energy that may be converted into liquid fuel is biomass, which contains carbon in its structural components. There are many thermochemical processes in converting raw biomass to fuels but the process of pyrolysis is still a popular way to turn biomass into bio-oil, a complex combination primarily made up of oxygenated organic molecules and light hydrocarbons with traces of nitrogen and sulfur. The high level of oxygen content in the oil rendered it unbecoming for direct application as fuel or refinery-ready feedstock. This review paper elucidates the various bio-oil production processes and upgrading methods using zeolite catalyst. More so it also focuses on the utilization of catalytic pyrolysis to produce high-quality bio-oil and cutting-edge methods for characterizing bio-oil. Lewis and Brønsted acid sites, the number of structurally arranged acid sites, and the amount of metal loading all have a significant impact on deoxygenation processes and the selective generation of aromatic hydrocarbons.

**Keywords:** Bio-oil, catalyst, zeolite and upgrading.



## OPTIMIZATION OF LINEAR ALKYL BENZENE YIELD USING DESIGN EXPERT

Isaac JATO<sup>1,2</sup>, Ahmed Mohammed INUWA<sup>2</sup>, Habibu Abubakar WANIYO<sup>2,3</sup>

<sup>1</sup>Department of Science Laboratory Technology, Federal Polytechnic N'yak Shendam, Plateau, Nigeria

<sup>2</sup>Department of Chemical Engineering, Abubakar Tafawa Balewa University P.M.B 0247, Bauchi, Nigeria

<sup>3</sup>Department of Chemical Engineering, Federal Polytechnic Kaltungo P.M.B 009, Gombe, Nigeria

### ABSTRACT

Linear alkyl benzene (LAB), the most widely used raw material in the synthesis of surfactant for use in the creation of biodegradable home cleaners such as detergent, soap, and shampoos, is used to meet the annual demand for high-value household detergents. In order to produce detergent of the highest calibre, linear alkyl benzene specifications must be standardized. The LAB yield is influenced by the uncertainty of the thermodynamic variables such as temperature, pressure, and flow rate. This study used Aspen Hysys to optimize the product yield at the Kaduna Refining and Petrochemical Company's (KRPC) linear alkyl benzene plant. The simulation and modelling results for the LAB production process using ASPEN HYSYS V.11 showed that the developed model was successful and was able to converge when simulated with Peng-Robison as fluid package to give the yield of LAB as 3800 kg/hr, which is very close to the actual LAB plant yield of 3788 kg/hr at the same feed rate. Furthermore, because the model was shown to be significant with Predicted R-Squared values of 0.5565 and R-Squared values of 0.7075, it can be utilized to accurately describe the behavior of the KRPC LAB plant. This equation was constructed using Design-Expert 13.0.0 for the LAB yield. Additionally, at the ideal operating PACOL temperature, pressure, and DETAL temperature, pressure of 457.349°C, 2.320 kg/cm<sup>2</sup>.g and 275.692°C, 2.815kg/cm<sup>2</sup>.g, respectively, the numerical optimization result was able to provide a great improvement in LAB yield value up to 2.10%. The process variables taken into account in the current study, it can be mentioned, contributed to a higher yield of the LAB product at the KRPC LAB plant section.

**Keywords:** Optimization, Linear Alkyl Benzene and Design Expert.

## II. International Energy Days

September 27<sup>th</sup>, 2023 / Sivas-Türkiye

Sivas Cumhuriyet University



### THE FUTURE OF ENERGY SUSTAINABILITY – A THOUGHT EXERCICE

**Professor Valentina Marinescu**

University of Bucharest

**PhD Ramona Marinache**

University of Bucharest

#### ABSTRACT

The 2030 Agenda for Sustainable Development is a document developed by United Nations as a ‘blueprint’ for the present and future of people and the planet. Assumed through this agenda by all UN member states there are 17 goals that comprise all human existence in its social and environmental interdependences, from economic well-being to gender equality, from individual production and use of energy to industry and economic growth. This presentation will focus only on the 7<sup>th</sup> goal of the agenda – ‘affordable and clean energy’ – in order to analyze the social sustainability of clean electric energy and efficient electric energy consumption in the process of shifting from oil and gas based production to ‘renewable resources’, to green energy. In order to do that we analyze the social chains of interdependences from the exploitation of resources used to produce the electric energy to the moment of the energy consumption by households and individuals. The overview will end with a few consideration on the possible social futures based on the variable ‘clean energy consumption’.

**Keywords:** Social sustainability, energy, future



## HYPERPARAMETER OPTIMIZATION: A CASE STUDY FOR GEOTHERMAL-THERMOELECTRIC EXPERIMENTAL SETUP

**Osman Dogukan URKAN**

Pamukkale University, Department of Computer Engineering, Denizli, Türkiye  
ORCID: 0009-0004-0477-4078

**Meriç CETİN**

Assoc. Prof. Dr. Pamukkale University, Department of Computer Engineering, Denizli, Türkiye (Responsible Author)  
ORCID: 0000-0002-7871-4850

**Mahmut HEKİM**

Assist. Prof. Dr. Karamanoglu Mehmetbey University, Vocational College of Technical Sciences, Karaman, Türkiye,  
ORCID: 0000-0002-2766-1023

### Abstract

Geothermal Energy Systems (GES), which produce energy using geothermal fluids, are frequently preferred energy production systems among renewable energy technologies. In this study, hot water flow and cold water flow have been estimated using the data obtained from a Thermoelectric Generator (TEG) experimental setup that generates electrical energy through thermal exchange. Support Vector Regression (SVR), K-Nearest Neighbor (KNN), Classification and Regression Tree (CART), Random Forest (RF) models have been used to evaluate the energy production performance of TEG in the regression process. In order to improve the prediction results, hyperparameter optimization has been performed in machine learning methods and the results have been presented with some metrics. The experimental results showed that hyperparameter optimization is an important process influencing power generation estimation in experimental geothermal-thermoelectric hybrid system.

**Keywords:** thermoelectric generator, geothermal power plant, regression models, hyperparameter optimization.

### Introduction

Increasing applications for the energy sector also lead to the development of renewable energy technologies that compete with fossil fuel-based traditional energy production systems. Geothermal Energy Systems, which are used for space heating and cooling, power technology, agricultural applications, cosmetics and many other purposes, are frequently preferred among renewable energy technologies (Haklıdır & Haklıdır, 2020). It is reported that the efficiency of geothermal power plants is at most 20% (EUTAF, 2016; Zarrouk & Moon, 2014). After energy generation in geothermal power plants, the geothermal fluid (containing a type of (waste) thermal energy) pumped into the re-injection well can be passed through TEGs and used again in electricity generation. In this way, the total energy production of a Geothermal Power Plant (GPP) can also be increased (Hekim & Cetin, 2019).

Machine learning-based intelligent methods can be used to increase power generation in geothermal systems. Different solutions are produced through linear or nonlinear models to model changes in the flow rate, temperature and pressure of the geothermal fluid. In the literature, methods such as regression models (Karadas et al., 2015), artificial neural networks (Yılmaz & Koyuncu, 2021), fuzzy logic applications (Haklıdır, 2020), extreme learning machines (Lai et al., 2020), support vector machines (Haklıdır & Haklıdır, 2020) are used for linear and nonlinear modeling in GPPs.

In this paper, hot water flow rate and cold water flow rate have been estimated using machine learning models with data obtained from an experimental setup designed to generate DC electrical energy through thermal interaction. To improve the performance of the designed models, hyperparameter optimization has been

performed and model parameters were optimized through various algorithms. In this way, the regression performance of the models has been improved. The performance evaluation metrics have confirmed the importance of hyperparameter optimization in energy production estimation.

### Materials and Methods

Machine learning algorithms generally aim to find a learning function that best maps input variables to an output variable. Non-parametric learning algorithms are quite successful in learning any mapping function from training data. Examples of non-parametric methods include decision trees such as classification and regression trees, methods such as Naive Bayes, support vector machines, and neural networks. In this section, intelligent models used in many scientific studies and preferred for regression in this study are briefly introduced.

#### Support Vector Regression (SVR)

Apart from classification processes, SVMs can also be applied to regression problems via a loss function. The purpose of the SVR method is to create an error-insensitive hyperplane by separating data classes and shrinking this area according to the extreme value of the data (Smola & Schölkopf, 2004). In the Vapnik loss function used to solve the regression problem, the minimum  $\epsilon$  error of the true value can be ignored. In  $\epsilon$ -SVR, it is desired to find the  $f(x)$  function with the greatest  $\epsilon$  deviation from the  $y_i$  values obtained for the input-output data  $((x_1, y_1), \dots, (x_l, y_l))$  where  $l$  is the number of training data. In this method, errors less than  $\epsilon$  are not considered and any deviation larger than  $\epsilon$  is not allowed. The linear function is  $f(x) = w^T \Phi(x + b)$  where  $w$  is the weight vector,  $x$  is the input vector,  $b$  is a deviation and  $\Phi(\cdot)$  is the nonlinear transformation. The convex optimization problem is as  $\min \frac{1}{2} \|w\|^2$ , subject to  $\forall i: |y_i - x_i^T w + b| \leq \epsilon, i = 1, \dots, l$  where  $w$  represents the margin. When it is not always possible to find the perfect function for all points, some errors are allowed so that the hard margin becomes the soft margin. For this, the slack variables  $\xi_i, \xi_i^*$  are used, resulting in the formulation specified by:

$$\min \frac{1}{2} \|w\|^2 + C \sum_{i=1}^l (\xi_i + \xi_i^*) \quad (1)$$

subject to  $y_i - (x_i^T w + b) \leq \epsilon + \xi_i, (x_i^T w + b) - y_i \leq \epsilon + \xi_i^*, \xi_i \geq 0, \xi_i^* \geq 0$ . Then  $|\xi|_\epsilon$

$$|\xi|_\epsilon = \begin{cases} 0, & \text{if } |\xi| \leq \epsilon \\ |\xi| - \epsilon, & \text{otherwise} \end{cases} \quad (2)$$

This optimization problem is easier to solve in the Lagrangian dual form. The Lagrangian multipliers  $\eta_i$  and  $\eta_i^*$  direct the predictions to the targets  $y_i$ . The weight vector in terms of these multipliers can be written as:  $w = \sum_{i=1}^l (\eta_i - \eta_i^*) \Phi(x_i)$ . Then the  $f(x)$  function is rewritten by substituting  $w$  into the  $f(x)$  function expression. Here,  $K(x_i, x)$  is the Kernel function.

$$f(x) = \sum_{i=1}^l (\eta_i - \eta_i^*) \Phi(x_i) \Phi(x) + b = \sum_{i=1}^l (\eta_i - \eta_i^*) K(x_i, x) + b. \quad (3)$$

#### K-Nearest Neighbor (KNN)

The nearest neighbor algorithm is a non-parametric method used to solve classification and regression problems (Li et al., 2010).  $k$ NN algorithm calculates the distances between all samples in the data and selects

the number sample closest to the query. In order to select the appropriate  $k$  value, the  $k$ NN algorithm is run several times with different values of  $k$  and the  $k$  value, which reduces the error in predictions, is selected. The similarity measure is defined with Euclidean distance (Ed) as follows:

$$\text{Similarity}(c_0, c_i) = \frac{1}{1 + a \times \text{Ed}(c_0, c_i)}, \quad (4)$$

$$\text{Ed}(c_0, c_i) = \left( \sum_j^j w_j \times d_j(c_0, c_i)^2 \right)^{\frac{1}{2}}, j = 1, \dots, n,$$

$$d_j(c_0, c_i) = |X_j^0 - X_j^i|.$$

All neighbors are determined according to the number of nearest neighbors, which are determined empirically, consensus among neighbors is calculated with the principle of pure majority voting as:  $I(c_0) = \max_z \sum_{(c_i, I(c_i) \in D)} L(z = I(c_i))$ , where  $D$ ,  $z$ ,  $c_i$  and  $L(\cdot)$  indicate the nearest set of neighbors to the target case, the class label, the  $i$ th nearest neighbor and a function that returns only 1 or 0, respectively.

### Classification and Regression Tree (CART)

CART is used to create decision trees where each root node represents a single input variable and leaf nodes represent an output variable used for prediction (Breiman, 2017). To create a problem-specific CART model, an appropriate tree is designed by selecting input values and split points on these values. A greedy algorithm is used to minimize the cost function by selecting the input variables or splitting points to use. This algorithm selects the best split point every time. The tree structure is then terminated with a stopping criterion. The CART algorithm uses the  $G_{ini}$  criterion, which stores the sum of squares of the probabilities of each class, to split the dataset into a decision tree with a best guess.  $G_{ini} = 1 - \sum_{i=1}^n (p_i)^2$ , where  $p_i$  indicates the probability that an object will be classified into a particular class. The regression process is mathematically expressed as  $\sum_{i=1}^n (y_i - \hat{y}_i)^2$  where all input variables and all possible split points are greedily evaluated ( $\hat{y}_i$  is the  $i$ th predictions).

### Random Forest (RF)

Random forests, commonly used in classification or regression processes, are a type of ensemble learning algorithm called Bagging or Bootstrap Aggregation (Breiman, 2001). Each decision tree in RF is trained with a random sample, and the outcome of the model is determined by the average of the outputs of all trees. This method is used to reduce the overfitting problem and improve the overall performance of the model. Random forest regression approach is an ensemble learning method developed based on decision trees to model output values corresponding to certain input values. In the random forest regression process, each tree produces a specific prediction, and the average prediction of individual trees is obtained as the output of the process.

### Hyperparameter optimization

Hyperparameter optimization is a process used to achieve the best performance of machine learning and deep learning models. Machine learning models have many parameters called hyperparameters to perform a specific task on the data. These parameters control factors such as how the model learns, how fast it learns, and how it affects its overall performance (Yang & Shami 2020). Hyperparameter optimization aims to find the best values of these hyperparameters, which can help the model achieve better performance and prevent overfitting. The optimization process can be accomplished through manual trial and error, grid search, random search, bayesian optimization or automatic hyperparameter optimization etc. In the next section, the contribution of the hyperparameter optimization used to obtain the best performance of the machine learning models to the results is presented.

## Findings and Discussion

### *The Geothermal-Thermoelectric Experimental Setup*

In this study, real-time data was collected from the experimental setup shown in Figure 1 in order to model electricity generation from waste geothermal fluid and estimate the real-time DC voltage of TEGs (Hekim & Cetin, 2021). Two of the three copper profiles seen in the GPP-TEG hybrid power system are connected to the cold water line representing the cooling water line in the GPP, and the third is connected to the hot water line representing the reinjected geothermal fluid line. TEG modules are placed above and below the hot water copper profile. The copper profile through which hot water passes is between two cold water copper profiles. Thus, one surface of the TEG module is in contact with the copper profile that carries hot water, and the other surface is in contact with the copper profile that carries cold water.

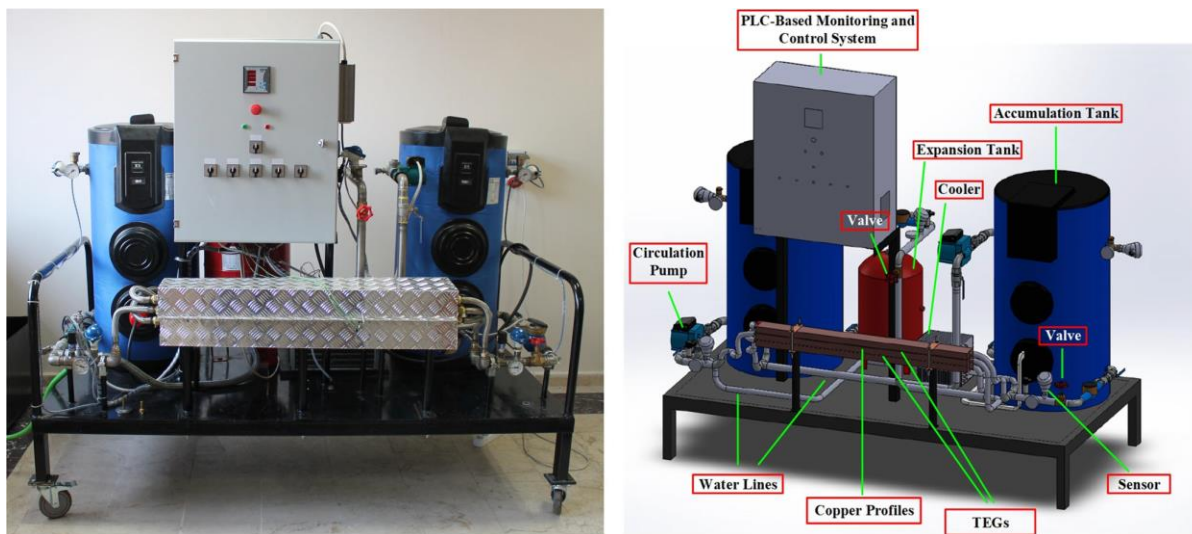

**Figure 1.** The general view of the experimental set-up (Hekim, 2021).

When the GPP-TEG system is put into operation, first of all, general control of the system is carried out by PECS. Then the heater is activated and starts heating the water in the hot water accumulation tank. The temperature of the water is controlled by PECS and adjusted not to exceed 100°C. The water in the experimental setup used as GPP cooling water is obtained by cooling the water in the cold water accumulation tank in the condenser. The lower limit value of cooling water is +4°C and is controlled by PECS. In this study, hot water flow and cold water flow have been estimated using data obtained from a TEG experimental setup that produces electrical energy through heat exchange. The input values of the machine learning models used in the regression process are: Hot Water Tank Temperature, Hot Water Return Temperature, Cold Water Tank Temperature, Cold Water Return Temperature, Hot Water Inlet Temperature, Cold Water Inlet Temperature, Hot Surface Temperature, Cold Surface Temperature, Hot Water Inlet Pressure, Hot Water Return Pressure, Cold Water Inlet Pressure and Cold Water Return Pressure. For the regression results in energy production, Hot Water Flow (ml/s) and Cold Water Flow (ml/s) output values were estimated using intelligent models.

Three different metrics namely Root Mean Square Error (RMSE), Mean Absolute Error (MAE) and R-Square ( $R^2$ ) are used to evaluate the regression performance of designed ML models. These metrics are formulated as follows.

$$RMSE = \sqrt{\frac{1}{N} \sum_{i=1}^N (y_i - \hat{y}_i)^2} \tag{5}$$

$$MAE = \frac{1}{N} \sum_{i=1}^N |y_i - \hat{y}_i|$$

$$R^2 = 1 - \frac{\sum_{i=1}^N (y_i - \hat{y}_i)^2}{\sum_{i=1}^N (y_i - \bar{y}_i)^2}$$

$y_i$  is the actual output value,  $\hat{y}_i$  is the predicted output value,  $\bar{y}_i$  is the mean value of the actual output and  $N$  is the number of data. **RMSE** and **MAE** values are expected to be small compared to the error rate. In addition, the higher value of  $R^2$ , the better performance is achieved.

Regression Results

In this study, both hot water flow rate and cold water flow rate have been predicted simultaneously using tank temperatures obtained from the heater and cooler units of TEG, which produces DC electrical energy through thermal interaction. Figure 2 shows the learning curves for regression predicting both hot water flow and cold water flow simultaneously using ML models without hyperparameter optimization. Figure 3 shows the learning curves for the regression that simultaneously predicts both hot water flow and cold water flow using ML models in the presence of hyperparameter optimization. Table 1 lists the numerical results expressed by various metrics for hot water flow and cold water flow prediction during the regression process. Table 2 lists the regression results for the tuned ML models. According to these results, it seems that machine learning models with hyperparameter optimization are more successful.

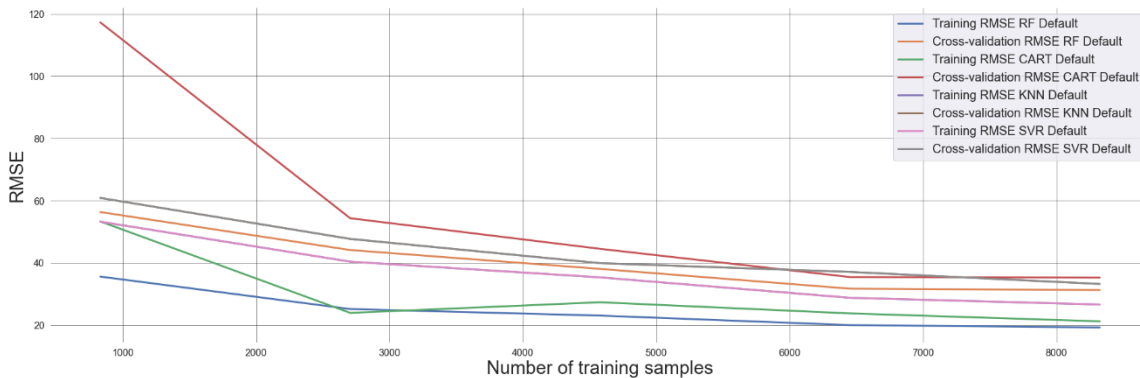

**Figure 2.** Cross-validation results of default models



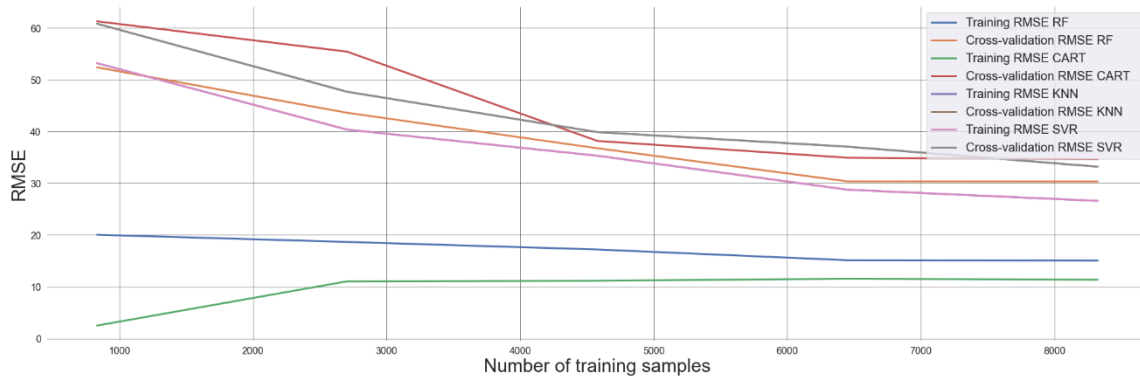

Figure 3. Cross-validation results of tuned models

Table 1. The numerical comparison of default models for regression

Model	RMSE	MAE	R <sup>2</sup>
SVR	63.66	20.84	0.9452
MSVR (Bao et al., 2014)	57.95	20.43	0.9528
KNN	46.90	9.61	0.9707
CART	56.21	13.46	0.9510
RF	49.83	11.06	0.9644

Table 2. The numerical comparison of tuned models for regression

Model	RMSE	MAE	R <sup>2</sup>
SVR	47.77	12.27	0.9685
MSVR (Bao et al., 2014)	46.56	12.58	0.9715
KNN	43.75	9.35	0.9743
CART	50.18	11.21	0.9754
RF	47.25	10.94	0.9672

The feature importance representation determines how important each feature is in the decision tree. Figure 4 and Figure 5 show the feature importance frequency of the RF model and CART for the experimental setup, respectively. According to this metric, the higher the feature importance frequency, the greater the impact on predictions. For example, Figure 4a shows the default feature importance frequency of the RF model. Accordingly, hot water inlet pressure has been found to be the most prioritized value for prediction of the default model. Other ongoing feature importances are hot water return pressure and cold water pump stage, respectively. On the other hand, when hyperparameter optimization has been performed for the RF model, feature importance values have been calculated as hot water return pressure and hot water inlet pressure and cold water pump stage, as seen in Figure 4b. In the experimental results given in tables, it is observed that hyperparameter optimization improves the performance results.

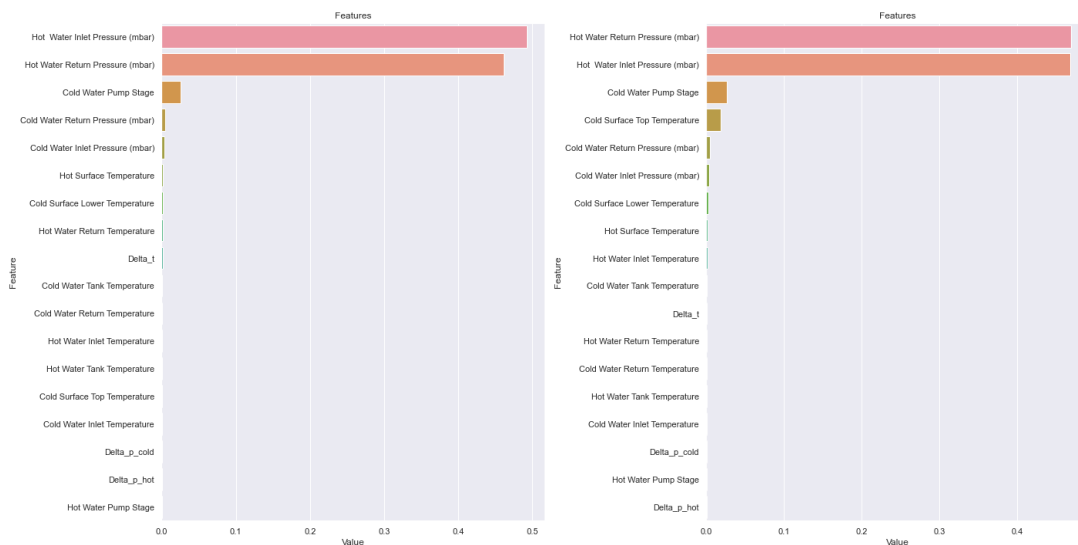

a) RF default model feature importances      b) RF tuned model feature importances

**Figure 4.** Feature importances of RF model

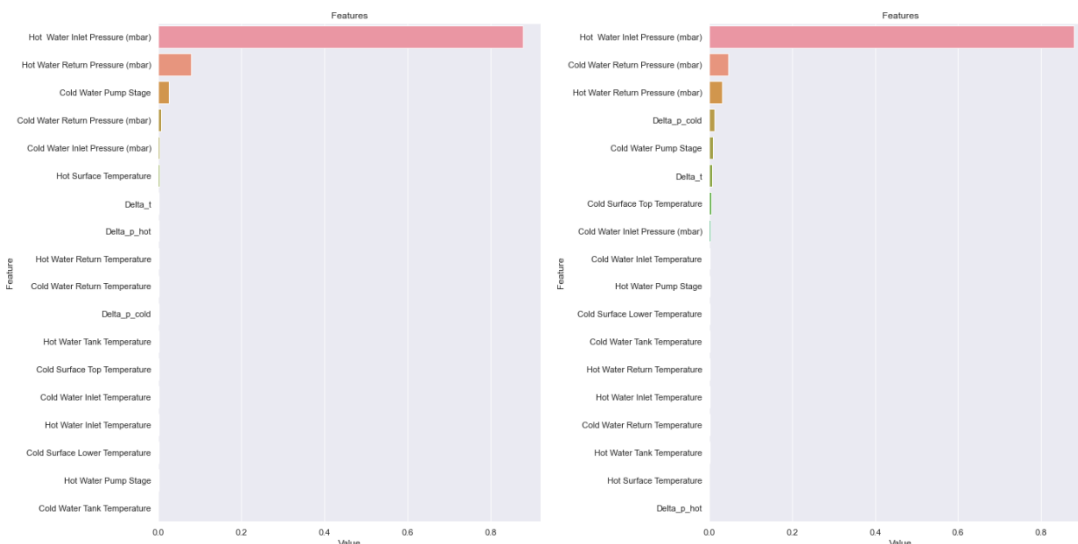

a) CART default model feature importances      b) CART tuned model feature importances

**Figure 5.** Feature importances of CART model

### Conclusion and Recommendations

Using geothermal fluid to generate electricity again before being sent to the re-injection well is a preferred method to increase power plant efficiency. In this paper, energy generation prediction has been carried out using various ML models with real-time data collected from an experimental setup designed in (Hekim, 2021), simulating Geothermal-TEG Hybrid Energy Systems. During the regression process, hyperparameter optimization has been performed to improve the prediction performance of intelligent models. Experimental results have been evaluated using commonly used metrics in the regression process. As a result, this study has made a contribution to the literature in terms of intelligent modeling of energy generation from waste geothermal fluid and hyperparameter optimization.

### Thanks and Information Note

We would like to thank Prof. Dr. Engin Cetin for his expert advice and encouragement throughout this difficult work.

### References

- Haklıdır, F. S. & Haklıdır, M. (2020). Prediction of reservoir temperatures using hydrogeochemical data, Western Anatolia geothermal systems (Turkey): a machine learning approach. *Natural Resources Research*, 29(4), 2333-2346.
- European Union Technical Assistance Facility (EUTAF). (2016) Sustainable Energy Handbook–Module 4.7 Geothermal Energy.
- Zarrouk, S. J. & Moon, H. (2014). Efficiency of geothermal power plants: A worldwide review. *Geothermics*, 51, 142-153.
- Hekim, M. & Cetin, E. (2019). Regeneration of electrical energy from waste geothermal fluid in geothermal power plants. *Academic Perspective Procedia*. 2(3):525-531.
- Karadas, M., Celik, H. M., Serpen, U. & Toksoy, M. (2015). Multiple regression analysis of performance parameters of a binary cycle geothermal power plant. *Geothermics*, 54, 68-75.
- Yilmaz, C. & Koyuncu, I. (2021). Thermoeconomic modeling and artificial neural network optimization of Afyon geothermal power plant. *Renewable Energy*, 163, 1166-1181.
- Haklıdır, F. S. T. (2020). The importance of long-term well management in geothermal power systems using fuzzy control: A Western Anatolia (Turkey) case study. *Energy*, 213, 118817.
- Lai, J. P., Chang, Y. M., Chen, C. H. & Pai, P. F. (2020). A survey of machine learning models in renewable energy predictions. *Applied Sciences*, 10(17), 5975.
- Smola, A. J. & Schölkopf, B. (2004). A tutorial on support vector regression. *Statistics and computing*, 14, 199-222.
- Li, H. Sun, J. & Wu, J. (2010). Predicting business failure using classification and regression tree: An empirical comparison with popular classical statistical methods and top classification mining methods. *Expert Systems with Applications*, 37(8), 5895-5904.
- Breiman, L. (2017). Classification and regression trees. *Routledge*
- Breiman, L. (2001). Random forests. *Machine learning*, 45, 5-32.
- Yang, L. & Shami, A. (2020). On hyperparameter optimization of machine learning algorithms: Theory and practice. *Neurocomputing*, 415, 295-316.
- Hekim, M. & Cetin, E. (2021). Energy analysis of a geothermal power plant with thermoelectric energy harvester using waste heat. *International Journal of Energy Research*, 45(15), 20891-20908.
- Hekim M. (2021). Investigation of energy recovery by thermoelectric effect from waste heat in geothermal power plants. *PhD. Thesis. Pamukkale University, Denizli-Turkey*.
- Bao, Y. Xiong, T. & Hu, Z. (2014). Multi-step-ahead time series prediction using multiple-output support vector regression. *Neurocomputing*, 129, 482-493.



## FABRICATION OF SILICON-BASED COMPOSITE COATING FOR ENERGY STORAGE AND SEMICONDUCTOR APPLICATIONS

**Prof. Dr. Mohammad Asaduzzaman Chowdhury**

Department of Mechanical Engineering, Dhaka University of Engineering & Technology, Bangladesh

**MD. HELAL HOSSAIN**

Department of Mechanical Engineering, Dhaka University of Engineering & Technology, Bangladesh

### ABSTRACT

In the modern world, energy is essential because it powers everything from industry and transportation to communication and everyday activities. Batteries are frequently viewed as one of the most significant energy storage technologies. Another essential element of electronics is semiconductors. They are extensively utilized in electronic devices like smartphones, laptops, microprocessors, memory modules, and other devices. Silicon has drawn a lot of interest in semiconductor and energy storage applications due to its distinctive properties. However, the rapid volume expansion rate of silicon as an anode material in Li-ion batteries is its principal drawback. This restriction has made silicon-based composites a popular and promising material. In this study, silicon-based composites are fabricated by coating with copper and aluminum foil. During the fabrication of the composite, silicon metal, silicon carbide, graphene, borophene, and binder (PAA) are mixed and finally coated by a bar coating method. The physical properties of all types of composites are characterized by UV, FTIR, and SEM methods, and performance is examined by the charging-discharging test. FTIR spectra of all samples showed two peaks at  $3853\text{ cm}^{-1}$  and  $3586\text{ cm}^{-1}$  due to the O-H stretching vibration indicating the presence of hydroxyl (-OH) groups, which is expected for silicone materials. And the presence of a large peak at  $2300\text{ cm}^{-1}$  indicates the introduction of graphene into the composite. UV test shows the band gap of the sample and clarifies whether it is conductive, semiconductive, or insulator. In the case of Si-SiC, a large absorption peak at 300 nm is found. We can see that the peak is decreasing gradually. For Si metal-Gr the peak is found at 296 nm, for Si-Gr-Br the peak is found at 297 nm, for Si-SiC-Gr the peak is found at 290 nm and for Si the peak is found at 292 nm. SEM images show the presence of different elements in the sample and grain boundaries are formed by several crystallographic areas. Random-shaped particles with sizes ranging from two hundred micrometers to twenty micrometers are observed. In the charging curve, the current slowly declines over time and eventually stabilizes. In contrast, the voltage drops over time in the discharge curve. The findings of this study are compared to those of other studies, and they can be applied to semiconductor applications and energy storage in the future.

**Keywords:** Lithium-ion batteries; anode material; energy; battery life cycle; environmentally acceptable energy sources;



### MAKİNE ÖĞRENMESİ ALGORİTMALARI KULLANILARAK KLİMA TÜKETİMİ TABANLI TOPLAM BİNA ENERJİ TÜKETİMİ TAHMİNİ

**Hasan YEŞİLYURT**

Enerji Yöneticisi, Aksaray Üniversitesi, Enerji Yönetimi Koordinatörlüğü, Aksaray-Türkiye (Sorumlu Yazar)  
ORCID: 0000-0002-0188-9388

**Ahmet Şakir DOKUZ**

Doç. Dr., Niğde Ömer Halisdemir Üniversitesi, Mühendislik Fakültesi, Bilgisayar Bölümü, Niğde-Türkiye,  
ORCID: 0000-0002-1775-0954

#### ÖZET

Bina sektöründe harcanan gereksiz enerji, dünyamızdaki iklim değişikliği ve küresel ısınma problemlerinin artmasına etki eden önemli bir konudur. Bu nedenle binalarda enerji tasarrufu yapmak ve enerji verimliliği önlemlerini planlamak gerekmektedir. Doğru enerji tüketim tahmini ve etkin enerji yönetim sistemi, bina enerji verimliliğinin iyileştirilmesinde önemli rol oynamaktadır. Son yıllarda veriye dayanan yöntemlerin kullanıldığı bina enerji tüketim tahmini gerçekleştiren çalışmalarda artış yaşanmaktadır. Makine öğrenmesi algoritmalarıyla doğru, güvenilir ve hızlı bina enerji tüketiminin belirlenmesi, bina sahiplerinin enerji verimliliğini gerçekleştirebilmesi için ilk adımdır. Bu çalışmanın amacı bir kampüs binasındaki klima tüketimini takip ederek doğru, güvenilir ve hızlı bir şekilde bina enerji tüketim tahmini gerçekleştirebilmek amacıyla makine öğrenmesi algoritmalarının performanslarını karşılaştırmaktır. İki farklı veri seti ile Knime Analitik Platformunda analizler ve görselleştirmeler yapılmıştır. Rasgele Orman, Gradyan Artırma Ağacı, Destek Vektör Makinesi, Yapay Sinir Ağı ve Derin Sinir Ağı olmak üzere 5 farklı makine öğrenmesi algoritması klima tüketimi verisi ile ve klima tüketimi verisi olmadan uygulanmış ve sonuçlar karşılaştırılmıştır. Bina enerji tüketim tahminini en doğru tahmin eden algoritma  $0.993 R^2$  ve  $1.98 RMSE$  değeri ile Rasgele Orman olmuştur. Deneysel sonuçlar, bir binada sadece klima tüketimi izlenerek toplam enerji tüketiminin yüksek başarı oranıyla tahmin edilebileceğini göstermektedir.

**Anahtar Kelimeler:** Bina Enerji Yönetim Sistemi, Bina Enerji Tüketim Tahmini, Makine Öğrenmesi, Knime Analitik Platform, Enerji Verimliliği.

### TOTAL BUILDING ENERGY CONSUMPTION FORECASTING BASED ON AIR CONSUMPTION USING MACHINE LEARNING ALGORITHMS

#### ABSTRACT

Unnecessary energy spent in the building sector is a critical issue that affects the increase of climate change and global warming problems in our world. For this reason, it is necessary to save energy in buildings and to plan energy efficiency measures. Accurate energy consumption estimation and effective energy management system play a vital role in improving building energy efficiency. In recent years, there has been an increase in studies that use data-based methods to estimate building energy consumption. Determining the correct, reliable and fast building energy consumption with machine learning algorithms is the first step for building owners to realize energy efficiency. The aim of this study is to compare the performance of machine learning algorithms to be able to make an accurate, reliable and fast estimation of building energy consumption by monitoring the air conditioning consumption in a campus building. Analyzes and visualizations were made by the Knime Analytics Platform with two different data sets. Five different machine learning algorithms, namely Random Forest, Gradient Boosted Trees, Support Vector Machine, Artificial Neural Network and Deep Neural Network, were applied with and without air conditioning consumption data, and the results were compared. The algorithm that most accurately estimates the building energy consumption was Random Forest, with an

R<sup>2</sup> of 0.993 and an RMSE of 1.98. Experimental results show that total energy consumption can be estimated with high success rate by monitoring only air conditioning consumption in a building.

**Keywords:** Building Energy Management System, Building Energy Consumption Forecasting, Machine Learning, Knime Analytical Platform, Energy Efficiency.

## 1. Giriş

Artan enerji tüketimi ile son yıllarda dünyamız iklim değişikliği ve küresel ısınma sorunları ile karşı karşıyadır. Bina sektörü, dünya enerji tüketiminin %33'üne ve sera gazı emisyonlarının %40'ına karşılık gelerek, küresel enerji tüketiminin en fazla olduğu sektör konumundadır (Lin vd., 2022). Bu nedenle, binalarda uygulanacak enerji yönetimi, binaların enerjisini verimli ve sürdürülebilir kullanmasını sağlayacağı gibi enerji tasarrufu ve emisyon azaltımı konusundaki hedeflere ulaşmayı hızlandıracaktır. Son yıllarda yapılan çalışmalar doğrultusunda enerji yönetimi konusunda, Bina Enerji Yönetim Sistemleri (BEYS) kavramı ortaya çıkmıştır. BEYS enerji tüketimi, enerji üretimi, enerji depolaması ve sistem kontrol ve entegrasyonu olmak üzere temelde 4 katmandan oluşur (Mariano-Hernández vd., 2021). BEYS enerji kullanımını yönetmeyi ve optimize etmeyi, maliyetleri düşürmeyi ve enerji planlaması yapabilmeyi amaçlayan bir dizi önlemleri ifade eden otomatik kontrol sistemidir.

Bina sahipleri ve işletmecilerin binalarının enerji tüketimini yönetmeleri önemlidir. BEYS, binaların enerji tüketimini kontrol ederek enerji verimliliğine odaklanmaktadır. BEYS'nin verimli şekilde çalışabilmesi için bina enerji tüketimini doğru bir şekilde tahmin edilebilmesi ve değişimleri yakalayabilmesi gerekmektedir. Bina enerji davranışının karmaşıklığı ve talepteki dalgalanma gibi etkileyen faktörlerin belirsizliği, enerji tüketim tahminini zor bir problem haline getirmektedir. Bu dalgalanmalar hava koşulları, bina özellikleri ve fiziksel etkenler, bina sakinleri ve davranışları ve alt seviye sistem bileşenlerinden kaynaklanmaktadır. Bu etkenler arasında olan klima sistemi, bir binadaki toplam elektrik enerjisi tüketiminin yaklaşık %50'sini oluşturmaktadır. Tüm bu zorluklara rağmen enerji tüketiminin tahmini, bina yöneticilerinin zaman içerisinde enerji kullanımını planlamasına, yoğun olmayan dönemlere kaydırılmasına ve daha etkili enerji satın alma, üretim ve depolama yapabilmelerine olanak taşımaktadır (Mocanu vd., 2014).

Bina enerji tüketimini tahmin etmek, enerji planlaması, yönetimi ve korunması için gereklidir. Bina enerji tüketim tahmini konusunda yapılan çalışmalar, fizik tabanlı (Zhai vd., 2012), veriye dayalı (Escriva vd., 2011) ve hibrit modeller (Yang vd., 2019) olarak üç ana kategoride listelenebilir. Son zamanlarda binalarda veriye dayalı yöntemi kullanarak elektrik tüketimi tahminine odaklanan çalışmalar hızla artmaktadır. Veriye dayanan modellerin en yaygın olanı makine öğrenmesi modelleridir. Walker vd. (2020) iki yıllık verilerle GAA, RO, DVM ve YSA yöntemlerini kullanarak saatlik enerji tahmini doğruluğunu karşılaştırmıştır. En iyi performansı GAA ve RO vermiştir. Dan vd. (2022) zaman serilerine dayalı olarak saatlik bina yükü tahmini için yeni bir yama öğrenme modeli önermiştir. Cao vd. (2023) kampüs binaları için yeni bir enerji tüketimi tahmin modeli önermiştir. Karşılaştırılması için kullanılan RO, GAA, DVM ve YSA modellerden en iyi sonucu RO vermiştir. Sapnken vd.(2023) binaların enerji talebinin doğru bir şekilde tahmin edilebilmesi için tasarım aşamasında yeni bir çerçeve geliştirmiştir. Çeşitli makine öğrenimi modellerini ve derin öğrenme potansiyelini farklı iklim bölgelerine odaklanarak incelemiştir.

Bu çalışmanın ana katkısı, bir binadaki klima tüketimi takip edilerek bina enerji tüketimi tahminini en az değişkenle, en doğru ve hızlı şekilde yapmak için makine öğrenmesi algoritmalarını kullanmaktır. Klima tüketiminin etkisini görebilmek için iki ayrı çalışma yapılarak karşılaştırma yapılmıştır. İlk çalışmada klima tüketiminin olmadığı veriler kullanılmış, ikinci çalışmada ise kullanılan veri setine ek olarak klima tüketimi verileri eklenmiştir. Seçilen makine öğrenmesi algoritmaları literatürde en sık kullanılan ve en doğru sonuca ulaştığı kanıtlanmış olan Rastgele Orman (RO), Gradyan Artırma Ağacı (GAA), Destek Vektör Makinesi (DVM), Yapay Sinir Ağları (YSA) ve Derin Sinir Ağları (DSA) algoritmalarıdır. Toplanan ve depolanan veriler Knime platformunda veri yükleme, veri ön işleme, veri analitiği ve görselleştirme-değerlendirme katmanlarından geçirilerek analiz edilmiştir (KNIME Analytics Platform, 2023).

Çalışmanın ikinci bölümünde kullanılan veri seti ve analiz aşamasında uygulanan yöntemler ile bunların değerlendirme kriterleri hakkında bilgiler açıklanmıştır. Üçüncü bölümde, yapılan çalışmalar sonucunda elde edilen bulgular paylaşılmış ve tartışmalar yapılmıştır. Dördüncü bölümde ise çalışma özeti sunulmuş, katkılar ve gelecekteki çalışmalar hakkında bilgiler verilmiştir.

## 2. Materyal ve Metot

Bu bölümde, çalışmada kullanılan materyal ve metot sunulmuştur. Öncelikle kullanılan veri kümesine ait özellikler sunulmuş, daha sonra seçilmiş olan algoritmalar tanıtılmış, son olarak önerilen klima tüketimi tabanlı bina enerji tüketimi tahmini yöntemi sunulmuştur.

### 2.1. Veri Kümesi

Bu çalışmada kullanılan veri seti, Aksaray Üniversitesi merkez kampüsündeki Rektörlük binasının saatlik olarak bir yıllık elektrik enerjisi tüketim verisidir. Bina yaklaşık 330 personel için çalışma alanı ve ofisler sunmaktadır. Bu çalışma, binanın elektrik enerjisi tüketimini tahmin etmek için klima tüketiminin dahil olduğu ve olmadığı 2 ayrı veri kümesi oluşturularak karşılaştırma yapılmaktadır.

İlk veri seti, girdi verileri olarak 3 girdi değişkeninden ve bir çıktı değişkeninden oluşmaktadır. Girdi değişkenleri, zamanla ilgili veriler olup 2022 yılı akademik takvimine göre tüm günleri kapsayacak şekilde belirlenmiştir. Yılın ayı (1...12), günün saati (0...23) ve haftanın günü (1...7) olacak şekilde 3 adet girdi değişkeni oluşturulmuştur. Çıktı verisi olarak da çalışma yapılan binanın toplam elektrik tüketimi değerleri kullanılmıştır. İkinci veri seti ise zamanla ilgili girdi değişkenlerine ek olarak binanın saatlik klima tüketimini de kapsamaktadır. Bu çalışmada kullanılan tüm değişkenler ilk veri seti ve ikinci veri seti olacak şekilde ayrı ayrı Tablo 1'de listelenmiştir.

**Tablo 1.** Veri setlerinde kullanılan değişkenler (I. ve II. veri seti)

I. Veri Seti				
No	Değişken	Giriş Tipi	Veri Tipi	Değer
1	Yılın Ayı	Zaman	Kategorik	1,2,...12
2	Günün Saati	Zaman	Kategorik	0,1,2,...23
3	Haftanın Günü	Zaman	Kategorik	1,2,...7
II. Veri Seti				
No	Değişken	Giriş Tipi	Veri Tipi	Değer
1	Yılın Ayı	Zaman	Kategorik	1,2,...12
2	Günün Saati	Zaman	Kategorik	0,1,2,...23
3	Haftanın Günü	Zaman	Kategorik	1,2,...7
4	Klima Tüketimi	Ölçülen	Sürekli	kWh
Çıktı Değişkeni				
--	Toplam Bina Elektrik Tüketimi	Ölçülen	Sürekli	kWh

Bu çalışmada kullanılan tüm değişkenler 01/01/2022-00:00 ile 31/12/2022-23:00 aralığında saatlik olarak izlenmiştir. Her bir değişken için 8760 veri noktası toplanmıştır. Zaman ile ilgili veriler oluşturulmuş olduğundan eksik veri bulunmamaktadır. Bina enerji izleme sisteminden alınan saatlik klima tüketim ve bina toplam elektrik tüketim değişkenlerinde de eksik veri bulunmamaktadır.

### 2.2. Makine Öğrenmesi Algoritmaları

Bu bölümde, bu çalışmada kullanılan RO, GAA, DVM, YSA ve DSA algoritmaları kısaca sunulmuştur.

#### 2.2.1. Rastgele Orman Algoritması (RO)

Birden fazla karar ağacı kullanarak daha tutarlı sonuçların elde edildiği topluluk öğrenme modeline dayanan bir karar ağacı sınıflandırma yöntemidir. Breiman (2001) tarafından önerilen bu yöntem, kategorik ve sayısal çıktı verileri için kullanılabilir. RO'nun avantajları hem regresyon hem de çok sınıflı sınıflandırma, az sayıda

ayarlama parametresi, karmaşık problemler için uygunluğun yanı sıra çapraz doğrulama ve değişken önemi görselleştirmesidir (Breiman, 2001).

### 2.2.2. Gradyan Artırma Ağacı Algoritması (GAA)

Sınıflandırma, regresyon ve sıralama gibi denetimli öğrenme görevleri için kullanılan bir karar ağacı yöntemidir. Bu yöntem birçok zayıf tahmin modelinden güçlü bir öğrenen elde edilmesini sağlar. GAA algoritması, özellik seçimi veya dönüşümü gerektirmez ve yüksek boyutlu seyrek verileri işleyebilir. Friedman tarafından gradyan artırma karar ağacına (GAA) dayalı olarak geliştirilmiş XGBoost, özellikle büyük veri kümelerini işleme ve hem yoğun hem de seyrek verilerle çalışma konusunda etkilidir (Duman, 2022).

### 2.2.3. Destek Vektör Makinesi Algoritması (DVM)

Vapnik ve Chervonenkis tarafından geliştirilen, istatistik öğrenme teorisine dayanan güçlü bir makine öğrenme yöntemidir. Destek vektör makineleri başlangıçta sınıflandırma problemlerini çözmek için tasarlanmasına rağmen, daha sonra ilkeleri yenilik tespiti veya regresyon gibi diğer tür problemleri çözmek için uyarlanmıştır. DVM'ler, araştırma topluluğunda en sağlam, doğru ve hesaplama açısından verimli veri madenciliği modelleri olarak kabul edilir ve giderek daha popüler hale geliyor (Sapnken vd., 2023).

### 2.2.4. Yapay Sinir Ağları (YSA)

1943'te Warren McCulloch ve Walter Pitt tarafından geliştirilen Yapay Sinir Ağlarında en çok kullanılan yapılardan biri, ileri beslemeli çok katmanlı algılayıcıdır (MLP). Enerji kullanımı hakkında güvenilir tahminler sağlamak için YSA'lar genellikle mevcut en iyi modeller olarak kabul edilir. YSA tekniğinin diğer sayısal algoritmalara göre en önemli faydaları, kolay uygulanabilir olması, yüksek hızı ve değişkenler ile alınan veriler arasındaki karmaşık ve doğrusal olmayan ilişkileri ele alma yeteneğidir (Ghritlahre & Prasad, 2018).

### 2.2.5. Derin Sinir Ağları (DSA)

Derin öğrenme, sinir ağlarının büyük veri kümelerinden öğrendiği bir yapay sinir ağı alt kümesidir. Bir DSA, yapay bir sinir ağının aksine birden fazla gizli katman kullanır. Klasik sinir ağlarına ek gizli katmanların eklenmesi, DSA'yı üstün bir makine öğrenimi tekniği yapar. Model derinliğinin getirdiği güçlü özellik çıkarma yetenekleri ve yüksek boyutlu veri işleme yetenekleri nedeniyle, bina enerji tahmini alanında artan sayıda araştırmacı tarafından tercih edilmektedir (Gao & Ruan, 2021).

## 2.3. Önerilen Yöntem

Bu çalışma, 5 farklı makine öğrenimi algoritması aracılığıyla toplam bina enerji tüketim tahminini en doğru şekilde yapabilmek için 2 farklı veri setinin karşılaştırmasını sunmaktadır. Bu çalışmada literatürde en yüksek doğrulukla tahmin gerçekleştiren algoritmalar seçilmiştir. Bu algoritmalarla oluşturulan modeller online bir veri bilimi platformu olan Knime üzerinde deneysel çalışmalar için hazırlanmıştır.

Uygulama aşaması temel olarak 4 katmanda gerçekleştirilmektedir: Veri Toplama ve Depolama Katmanı, Enerji İzleme ve Ölçüm Sisteminden kaydedilen klima ve bina enerji tüketim verileri ile zamanla ilgili oluşturulan veriler excel formatında birleştirilerek veri seti oluşturulmaktadır. Veri Yükleme ve Ön İşleme Katmanı, oluşturulan excel formatındaki dosyanın Knime platformuna düğümler vasıtasıyla eklenmesi ve bir dizi işlemlerden geçmesini içermektedir. Tüm bu ön işlemlerden geçirildikten sonra oluşturulacak modellerin birbiri arasında doğru kıyaslanabilmesi için normalizasyon işlemi gerçekleştirilmektedir. Veri Analitiği Katmanı, ön işlemden geçen verilerin eğitim ve test olarak bölünmesi, makine öğrenmesi modellerinin oluşturulması, tahminlerin gerçekleştirilmesi ve normalize edilen değerlerin gerçek değerlere dönüştürülmesini içermektedir. Normalize edilen değerler eğitim ve test kümelerine 10 katlı çapraz doğrulama kullanılarak bölünmekte ve çalıştırılmaktadır. Bu sayede tüm veriler bir kez test verisi olarak algoritmalara giridi sağlamaktadır. 5 ayrı model oluşturulduktan sonra model eğitimi ve tahmini gerçekleştirilmektedir.



Sonuç olarak bulunan değerler 0-1 aralığında olduğu için bu aşamada denormalizasyon işlemi yapılarak gerçek değerlere ulaşılmaktadır. Son olarak Görselleştirme ve Değerlendirme aşamasında ise bulunan değerlerin grafikler ile gösterilmesi ve modellerin performans değerlendirmesini içermektedir. Tüm bu işlemleri özetleyen akış diyagramı Şekil 1’de gösterilmektedir.

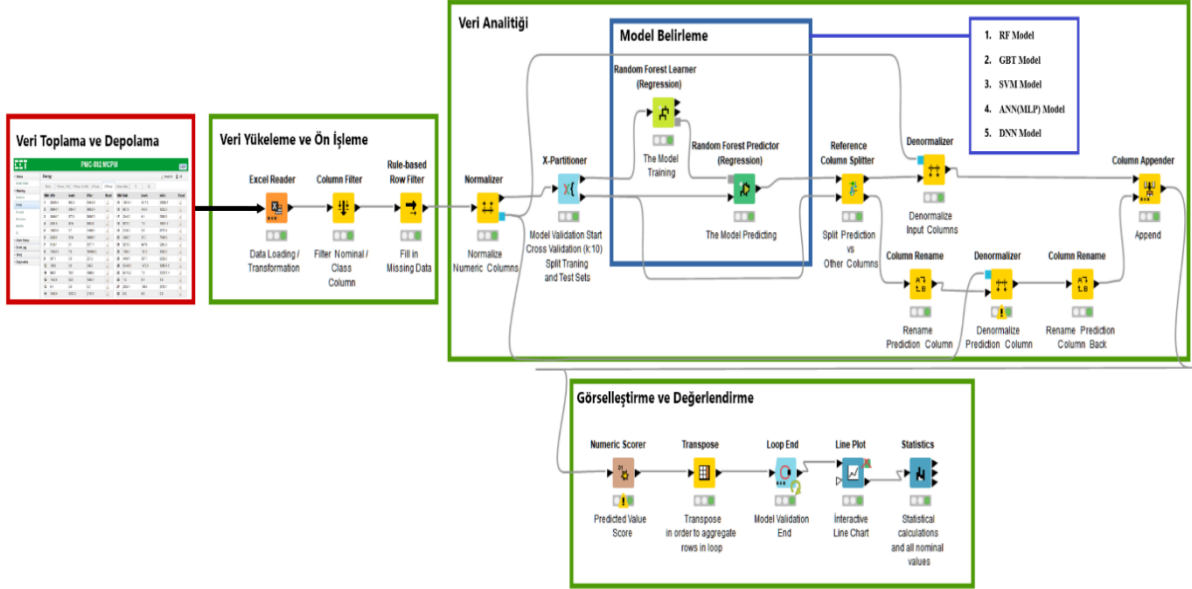

Şekil 1. Araştırma çerçevesi

## 2.4. Performans Değerlendirmesi

Ortalama karekök hatası (RMSE) ve belirleme katsayısı ( $R^2$ ), makine öğrenmesi modellerini değerlendirmek için yaygın olarak kullanılan istatistiksel yöntemlerdir. Bu nedenle, bu metrikler bu çalışmada bina enerji tüketim tahmin doğruluğunu değerlendirmek ve karşılaştırmak için kullanılmıştır. RMSE'nin düşük değerleri,  $R^2$ 'nin yüksek değerleri daha iyi tahmin doğruluğunu göstermektedir.  $R^2$  ve RMSE'ye ait formüller aşağıda sunulmuştur (Walker vd., 2020).

$$R^2 = 1 - \frac{\sum_{i=1}^N (y_i - \hat{y}_i)^2}{\sum_{i=1}^N (y_i - \bar{y})^2}$$

$$RMSE = \sqrt{\frac{\sum_{i=1}^N (y_i - \hat{y}_i)^2}{N}}$$

## 3. Bulgular

Bu bölümde, bina enerji tüketim tahmini için yapılan deneysel çalışmalar ve sonuçlar sunulmuştur. Deneysel çalışmalarda RO, GAA, DVM, YSA ve DSA algoritmaları ile 10 katlı çapraz doğrulama yapılarak bina enerji tüketim tahmini gerçekleştirilmiştir. Algoritmalar her iki veri seti üzerinde çalıştırılarak performansları elde edilmiştir.

Tablo 2, ilk veri setiyle birlikte modellerin tahmin sonuçlarının ortalama hata değerlerini, Şekil 2 ise çapraz doğrulama sonuçlarını içeren kutu grafiklerini göstermektedir.

**Tablo 2.** İlk veri seti ile modellerin ortalama tahmin sonuçları

No	Model İsmi	R <sup>2</sup>	RMSE (kWh)
1	RO (Rastgele Orman)	0,803	10,61
2	GAA (Gradyan Artırma Ağacı)	0,869	8,66
3	DVM (Destek Vektör Makinesi)	0,476	17,32
4	YSA (Yapay Sinir Ağı)	0,838	9,62
5	DSA ( Derin Sinir Ağı)	0,739	12,31

İlk veri seti için en doğru sonucu gösteren algoritma GAA olmuştur. GAA algoritmasına ait R<sup>2</sup> değeri 0,869 ve RMSE değeri 8,66 kWh'dir. En kötü performans ise R<sup>2</sup> değeri 0,476 ve RMSE değeri 17,32 ile DVM algoritmasıdır.

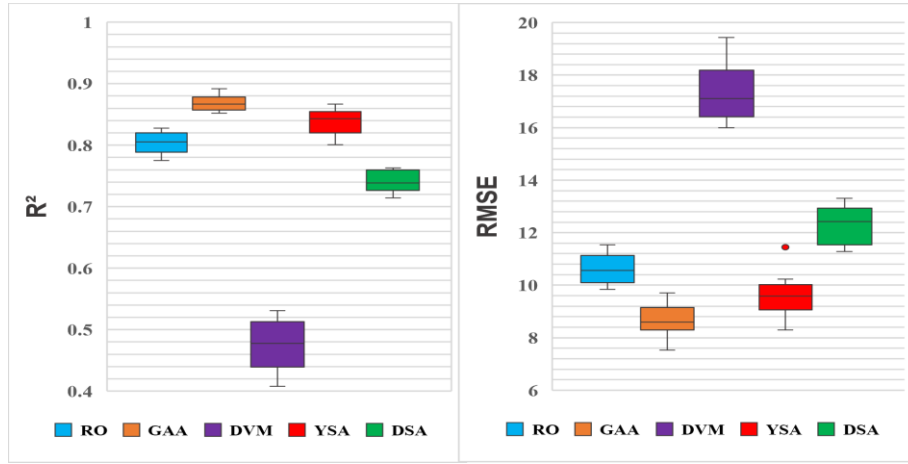
**Şekil 2.** İlk veri seti ile modellerin çapraz doğrulama tahmin sonuçlarını gösteren kutu grafikleri

İkinci veri seti kullanıldığı zaman ise tahmin edilen değerlerin hata oranlarında ciddi oranda azalma olmuştur. En başarılı R<sup>2</sup> değerine sahip model 0,993 ile RO'dur. Bunu 0,992 ile YSA ve 0,991 ile GAA izlemektedir. En son sıradaki algoritma 0,966 değeriyle DVM olmuştur. Bu hata değeri bile literatürdeki performans değerlendirme sonuçlarına bakıldığında çok iyi bir değerdir. RMSE değerlerinde de en az hata veren R<sup>2</sup> sıralamasıyla aynıdır. Tablo 3, tüm bu sonuçları açıklamaktadır. Şekil 3 ise klima tüketimi ile beraber bina elektrik tüketimi tahmini çapraz doğrulama sonuçlarını kutu grafiğinde göstermektedir.

**Tablo 3.** Klima tüketim değişkeni ile birlikte modellerin ortalama tahmin sonuçları (ikinci veri seti)

No	Model İsmi	R <sup>2</sup>	RMSE (kWh)
1	RO (Rastgele Orman)	0,993	1,98
2	GAA (Gradyan Artırma Ağacı)	0,991	2,23
3	DVM (Destek Vektör Makinesi)	0,966	4,37
4	YSA (Yapay Sinir Ağı)	0,992	2,13
5	DSA ( Derin Sinir Ağı)	0,980	3,23

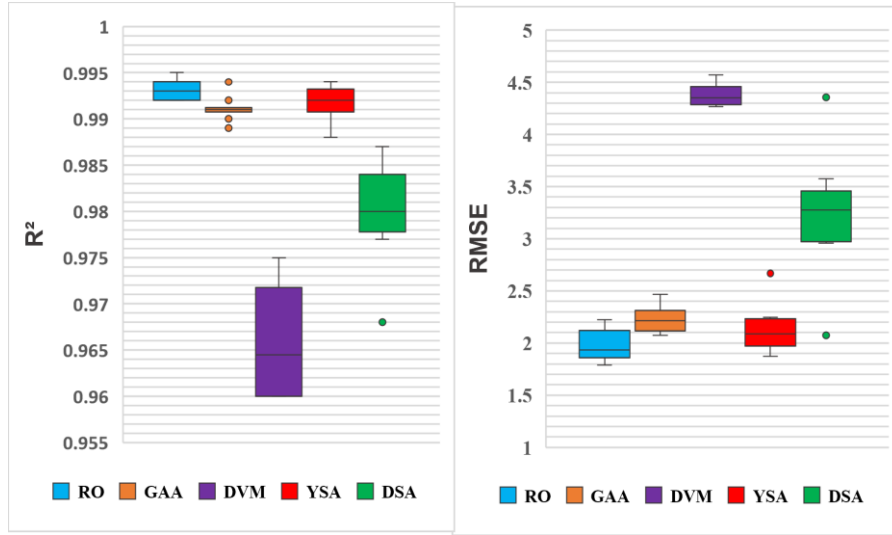

Şekil 3. İkinci veri seti ile modellerin klima tüketimi değişkeni ile birlikte çapraz doğrulama tahmin sonuçlarını gösteren kutu grafikleri

Klima tüketimi girdi değişkeni dahil edilerek bina elektrik tüketim tahmini gerçekleştirildiğindeki değerler ile dahil edilmediğindeki değerler karşılaştırılmıştır.  $R^2$  hata oranı %103,1 ile en fazla iyileştirme gerçekleştiren algoritma DVM ve %14,1 oranla en az iyileştirme sağlayan algoritma ise GAA'dır.  $R^2$  değerleri diğer iyileştirme oranları ise %32,5 ile DSA, %23,6 ile RO ve %18,4 ile YSA'dır. Şekil 4'teki grafik klima tüketimi değişkeni olduğunda ve olmadığındaki ortalama  $R^2$  hata performanslarının karşılaştırmasını göstermektedir. Klima tüketimi girdi değişkeni ile bina elektrik enerjisi tahmin performansı, dikkate katılmadığındaki  $R^2$  hata oranına göre tüm algoritmalarda ortalama %38,3 daha iyi bir değere sahip olduğunu göstermektedir. Şekil 5 ise ortalama RMSE değerlerinin karşılaştırmasını sunmaktadır.

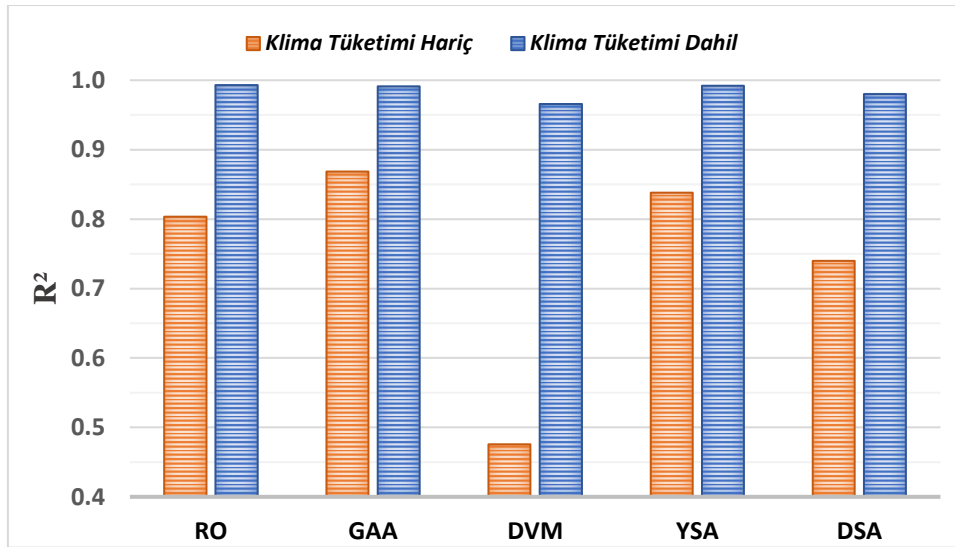

Şekil 4. Klima tüketimi ile ve klima tüketimi olmadan bina elektrik tüketim tahmini ortalama  $R^2$  hata değerleri karşılaştırması

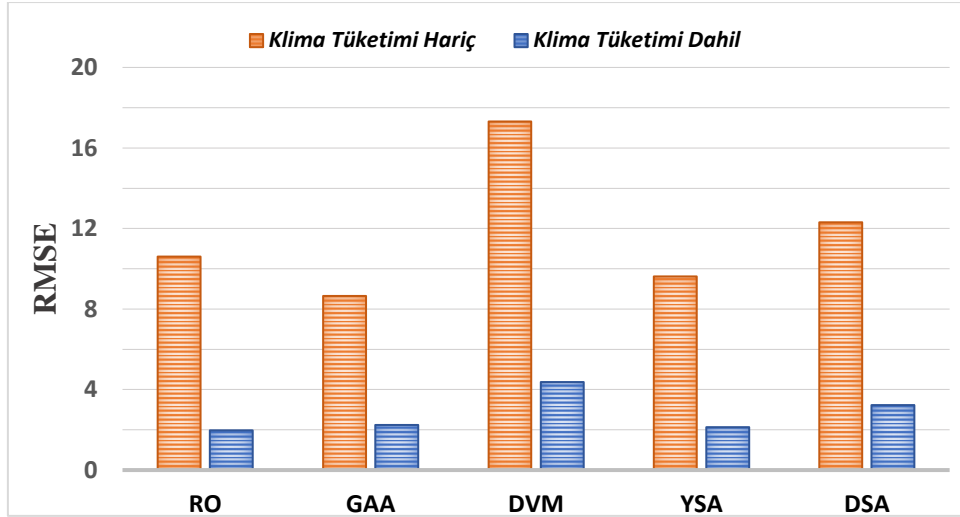

Şekil 5. Klima tüketimi ile ve klima tüketimi olmadan bina elektrik tüketim tahmini ortalama RMSE hata değerleri karşılaştırması

#### 4. Sonuçlar

Bina enerji talep tahmini yoluyla binalardaki kesin enerji tüketiminin belirlenmesi, enerji verimliliği ve sürdürülebilir enerjili binalara geçiş için hayati önem taşımaktadır. Bu çalışmanın ana katkısı, bir binadaki klima tüketimini takip ederek doğru, güvenilir ve hızlı bir şekilde bina enerji tüketim tahmini gerçekleştirebilmek amacıyla makine öğrenmesi algoritmalarını karşılaştırmaktır. Aksaray Üniversitesi Rektörlük binasında bir yıl boyunca saatlik olarak ölçülen ve kaydedilen veriler, Knime Analitik Platforma yüklenerek analiz aşamasına uygun hale getirilmiştir. Sonrasında veriler popüler makine öğrenmesi algoritmalarıyla analiz edilmiş ve görselleştirmeler yapılarak karşılaştırmalar çalışmaya eklenmiştir. Analiz sonucu bir binadaki klima tüketimi izlenerek toplam enerji tüketiminin tahmin edilebileceğini göstermektedir. Bina enerji tüketim tahmini için Rasgele Orman, Gradyan Artırma Ağacı, Destek Vektör Makinesi, Yapay Sinir Ağları ve Derin Sinir Ağları veri setine uygulanarak sonuçlar elde edilmiştir. Yapılan testler sonucunda Rastgele Orman algoritması 0.993  $R^2$  ve 1.98 RMSE hata değerleri ile en iyi sonuca sahiptir. Modeller sıralamasında en sondaki Destek Vektör Makinesinin  $R^2$  ve RMSE değerleri sırasıyla 0.966 ve 4.37'dir.

Gelecekte, BEYS'nin bir binaya kurulması sonrası enerji tüketim tahmininin aktif olarak gerçekleştirmek ve bunu otomatik olarak belli zamanlarda güncelleştirmek, farklı bina türlerinde de aynı sonuca ulaşmak ve derin öğrenme modellerinin doğruluğunun artırılması için uzun süreli veri setleri oluşturma planlanmaktadır.

#### Teşekkür ve Bilgi Notu

Aksaray Üniversitesi'ne 2022 yılı boyunca saatlik olarak kaydedilen toplam elektrik ve klima tüketimi verilerini paylaştığı için teşekkürlerimizi sunarız.

#### Kaynaklar

Breiman, L. (2001). Random Forests. *Machine Learning*, 45(1), p.5-32.

Cao, Y., Liu, G., Sun, J., Bavirisetti, D. and Xiao G. (2023). PSO-Stacking Improved Ensemble Model for Campus Building Energy Consumption Forecasting Based on Priority Feature Selection. *Journal of Building Engineering*, 72, 106589.

Chen, Y., Guo, M., Chen, Z., Chen, Z. and Ji, Y. (2022). Physical Energy and Data-Driven Models in Building Energy Prediction: A Review. *Energy Reports*, 8, p.2656-2671.

- Dan, Z., Wang, B., Zhang, Q., Wu, Z., Fan, H., Liu, L. and Sun, M. (2022). Fitting Multiple Temporal Usage Patterns in Day-Ahead Hourly Building Load Forecasting Under Patch Learning Framework. *Neural Computing and Applications*, 34, p.16291–16309.
- Duman, E. (2022). Implementation of XGBoost Method for Healthcare Fraud Detection. *Techno-Science*, 5(2), p.69-75.
- Escriva-Escriva, G., Alvarez-Bel, C., Roldan-Blay, C. and Alcazar-Ortega M. (2011). New Artificial Neural Network Prediction Method for Electrical Consumption Forecasting Based on Building End-Uses. *Energy and Buildings*, 43(11), p.3112–3119.
- Gao, Y. & Ruan, Y. (2021). Interpretable Deep Learning Model for Building Energy Consumption Prediction Based on Attention Mechanism. *Energy and Buildings*, 252, 111379.
- Ghritlahre, H. & Prasad, R. (2018). Application of ANN Technique to Predict The Performance of Solar Collector Systems - A Review. *Renewable and Sustainable Energy Reviews*, 84, p.75-88.
- KNIME Analytics Platform (KNIME). 2023. Access Address (04.10.2023): <https://www.knime.com/knime-analytics-platform/>
- Lai, F., Magoules, F. and Lherminier F. (2008). Vapnik's Learning Theory Applied to Energy Consumption Forecasts in Residential Buildings. *International Journal of Computer Mathematics*, 85(10), p.1563–1588.
- Lin, C., Lin, S., Liu, H. and Tseng, K. (2022). Applying the Naive Bayes Classifier to HVAC Energy Prediction Using Hourly Data. *Microsystem Technologies*, 28, p.121–135.
- Mariano-Hernandez, D., Hernandez-Callejo, L., Zorita-Lamadrid, A., Duque-Perez, O. and Santos García, F. (2021). A Review of Strategies for Building Energy Management System: Model Predictive Control, Demand Side Management, Optimization and Fault Detect & Diagnosis. *Journal of Building Engineering*, 33, 101692.
- Mocanu, E., Nguyen, P., Gibescu, M. and Kling, W. (2014). Comparison of Machine Learning Methods for Estimating Energy Consumption in Buildings. In: 2014 International Conference on Probabilistic Methods Applied to Power Systems (PMAPS). Accessed on 4 Aug 2023, available online at: <https://ieeexplore.ieee.org/document/6960635/>
- Sapnken, F., Hamed, M., Soldo, B. and Tamba, J. (2023). Modeling Energy-Efficient Building Loads Using Machine-Learning Algorithms for The Design Phase. *Energy and Buildings*, 283, 112807.
- Walker, S., Khana, W., Katic, K., Maassen, W. and Zeiler, W. (2020). Accuracy of Different Machine Learning Algorithms and Added-Value of Predicting Aggregated-Level Energy Performance of Commercial Buildings. *Energy and Buildings*, 209, 109705.
- Yang, Y., Che, J. and Deng, C. and Li, L. (2019). Sequential Grid Approach Based Support Vector Regression for Short-Term Electric Load Forecasting. *Applied Energy*, 238, p.1010-1021.
- Zhai Z., Chen, Q., Haves, P. and Klems, J. (2002). On Approaches to Couple Energy Simulation and Computational Fluid Dynamics Programs. *Building and Environment*, 37(8-9), p.857-864.



### DESIGN AND SIMULATION OF PHOTOVOLTAIC ENERGY STORAGE SYSTEM FOR TEMPORARY SHELTERS AFTER DISASTERS

**Emre ÖZER**

Lecturer, Gaziantep Islam Science and Technology University, Gaziantep -Türkiye  
(Responsible Author) ORCID: 0000-0001-5881-2253

**Furkan DİNÇER**

Associate Professor, Kahramanmaraş Sütçü İmam University, Faculty of Engineering and Architecture, Department of Electrical and Electronics Engineering, Kahramanmaraş-Türkiye, ORCID: 0000-0001-6787-0850

#### ABSTRACT

After the significant earthquake of February 6, 2023, temporary accommodation centers were established in many cities within Türkiye. During such emergency situations, it is extremely important to meet the energy needs and support the return of society to normal. In this study, a grid-connected rooftop photovoltaic system with energy storage is realized to meet the energy needs of a family staying in a temporary shelter located in Osmaniye, Türkiye. The proposed system is designed with the specific goal of addressing the electrical energy needs of a family consisting of four individuals, utilizing photovoltaic panels positioned on top of the container house that serves as their temporary dwelling. The system was simulated and discussed. Realized outcomes revealed an efficiency of 82.3% for the system, which is equipped with a nominal photovoltaic power of 3.6 kWp. Furthermore, this configuration system combines photovoltaic panels, energy storage batteries and grid connection to provide shelters with an efficient, resilient and sustainable power source. It generates an annual energy output of 5.36 MWh, effectively mitigating a total of 6.17 tons of CO<sup>2</sup> emissions.

**Keywords:** Container home, energy storage, earthquake, photovoltaic

#### Introduction

Earthquakes are natural disasters that can result in substantial harm to energy infrastructure and lead to power disruptions. Following the earthquake in Turkey on February 6, 2023, the total count of dwellings categorized as requiring immediate demolition, collapsed, or experiencing severe damage was identified as 518.009 (SBB, 2023). Consequently, temporary shelters have been established to address the housing needs of earthquake victims. However, in these centers, the provision of fundamental energy requirements such as lighting, heating, cooling, and access to clean water is just one aspect. In addition to these necessities, there are other vital energy needs like communication and connectivity services, as well as requirements related to medical facilities and services.

Container houses, with their portable and modular structures, have caught the attention of researchers due to their potential in reducing construction waste and CO<sub>2</sub> emissions. While the number of simulation studies in the literature to meet the energy needs of container buildings is limited, they do exist. These studies primarily focus on evaluating energy consumption and solar energy potential of container buildings, as well as sizing photovoltaic (PV) systems and assessing power generation. Kristiansen et al. conducted a study using the TRNSYS program to examine the situation of an off-grid container house in China (Kristiansen, Zhao, Ma, & Wang, 2021). On the other hand, Mansur et al. conducted a design and performance analysis of a system using PVsyst for a disaster relief center in a city in Malaysia (Mansur, Baharudin, & Ali, 2018).

In the design, simulation and performance analysis of photovoltaic systems, widely used programs such as PV\*SOL, HOMER, TRNSYS and PVsyst are used (Dincer and Ozer, 2023). In the PVsyst software, data entries such as location information (latitude, longitude), solar radiation data, module and inverter features are automatically defined from current databases and easy access is provided. It allows the selection of many different PV modules and inverters in terms of System Design. With these features, PVsyst differs from other

simulation programs in that it creates 3D structures, creates close shading simulations, calculates detailed system losses and makes economic evaluations, and presents them in the form of graphical tables and reports.

In this study, a grid-connected rooftop photovoltaic system with energy storage is realized to meet the energy needs of a family staying in a temporary shelter located in Osmaniye, Türkiye. The proposed system is designed with the specific goal of addressing the electrical energy needs of a family consisting of four individuals, utilizing photovoltaic panels positioned a top the container house that serves as their temporary dwelling. The system was simulated and discussed.

### Materials and Methods

In this study, the PVsyst 7.4 software demo is used and realized in order to design the proposed system. Selected simulation program is a widely used program for the design, simulation, and performance analysis of PV systems, was utilized in the system design for this study. This study was conducted at the container city located in the Dereobasi district of Osmaniye, at the geographical coordinates shown in Figure 1. Coordinate information of the selected region is Latitude: 37° 2'53.42" N, Longitude: 36°14'49.60"E.



**Figure 1.** Selected location for temporary shelters

For the meteorological data of the designated location, synthetic data was generated using Meteonorm 8.1. Details regarding the weather conditions can be found in Table 1. The panels integrated into the system are positioned on fixed tilted planes, with the following parameters: tilt angle of 7° and azimuth angle of 17°.

**Table 1.** Meteorological data for the selected location

	Global horizontal irradiation (kWh/m <sup>2</sup> )	Horizontal diffuse irradiation (kWh/m <sup>2</sup> )	Temperature (°C)	Wind Velocity (m/s)	Global incident in coll. plane (kWh/m <sup>2</sup> )	Albedo (kWh/m <sup>2</sup> )
January	69.9	36.26	9.35	2.4	79.1	0.052
February	81.0	42.27	11.15	2.3	88.7	0.060
March	128.6	62.89	14.52	2.3	136.2	0.096
April	158.3	78.31	17.82	2.2	163.6	0.118
May	196.2	87.96	22.20	2.1	198.6	0.146
June	220.8	74.54	26.04	2.5	221.7	0.162
July	221.5	77.97	29.15	2.6	223.0	0.164
August	203.1	67.40	29.79	2.4	208.8	0.152
September	167.8	48.26	26.45	2.1	178.3	0.124
October	121.9	50.40	22.31	2.2	133.4	0.091
November	83.6	30.58	16.04	1.8	96.1	0.063
December	68.4	30.09	11.14	2.2	80.1	0.051
Year	1721.2	686.93	19.71	2.3	1807.5	1.279

The block diagram of the system is shown in Figure 2. PV panels are mounted on a standard container with dimensions of 3m in width and 7m in length (Type D, 3x7m), commonly used in our country (Tanyer, Tavukcuoglu, & Bekboliev, 2018). The primary purpose of the PV panels is to generate electricity energy to meet the energy demands of the users residing in the container. The energy provided from the PV panels is used both for consumption and for charging the battery storage system. During periods when the electricity generated by the PV panels is insufficient for immediate usage or when there is no solar energy generation (e.g., during nighttime), the system draws power from both the battery storage and the main electricity grid, as necessary, to meet the energy requirements of the users.

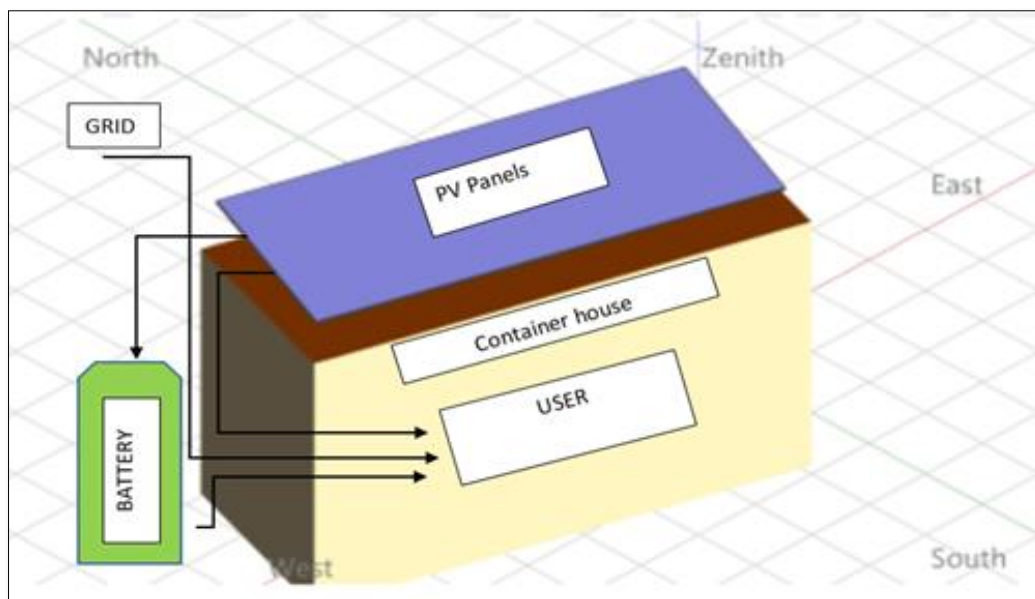
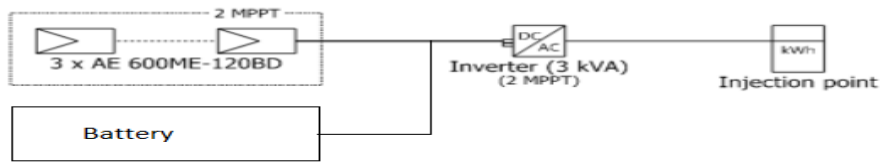

**Figure 2.** Proposed block diagram of the grid-connected photovoltaic energy storage system



This integrated approach ensures a reliable and continuous power supply to the occupants, utilizing solar energy efficiently during sunny hours, storing excess energy for later use, and seamlessly switching to alternative power sources when needed, providing a reliable energy solution for the container-based living arrangement.

In the system whose single line diagram illustrated in Figure 3. A total of 6 PV panels arranged in 2 strings of 3 modules connected in series. The chosen PV modules are AE Solar, Si-Mono technology with a nominal power of 600Wp, known for their high energy production per square meter. These modules were manufactured in 2022, and their current-voltage characteristics are displayed in Figure 4. The energy obtained from the modules is converted into AC energy by the 3.8 kW Inverter. Manufactured by Tesla inverter operating voltage is 60-480 V and max. efficiency is 98.40 %. In addition, it has 2 MPPT inputs and maximum current per MPPT 25.8 A. and absolute maximum PV input DC voltage value is 600 V.



**Figure 3.** Proposed system project diagram

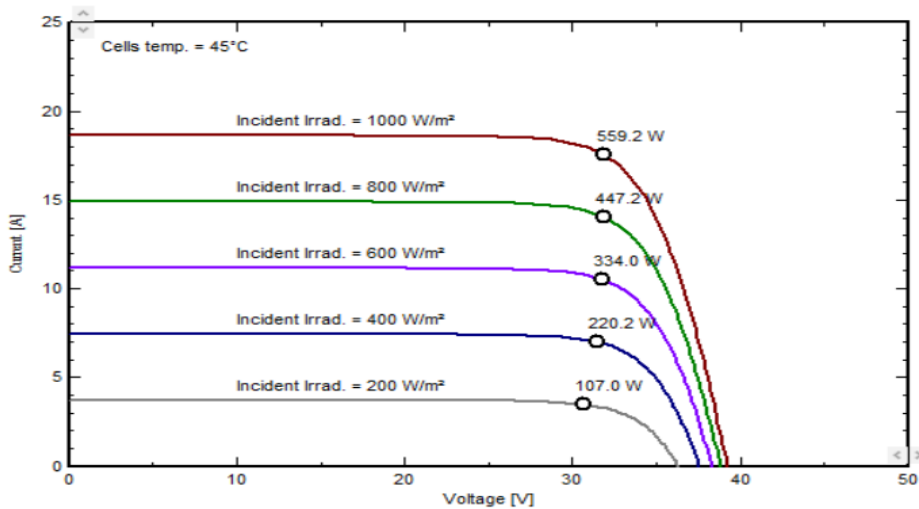

**Figure 4.** Current-voltage characteristics of the selected PV panel

The electricity consumption of the proposed system was established based on the average daily electrical energy requirement of a family of four, which is assumed to be 8 kWh according to the study by Şahin (2022). As a result, the annual electricity consumption is calculated to be 2.92 MWh. This value represents a constant electricity consumption rate throughout the year.

An important component of the system is the battery system. This system uses Lithium-ion battery manufactured by Huawei. The parameters of the battery are as follows: It has a nominal voltage of 48.0V and reaches a capacity of 200.00 Ah capacity (at C10). It consists of 30 cells in total. As can be seen in Figure 5. The charge cut-off voltage of the battery is 54.0 V, the discharge cut-off voltage is 40.5 V. The battery stored energy (80% DOD) is 7.79 kWh, the total stored energy (5000 cycles) is 38.9 MWh. In addition, the specific energy of the battery is 68 Wh/kg, its total weight is 107 kg. The summary of the proposed model technical properties is given in Table 2.

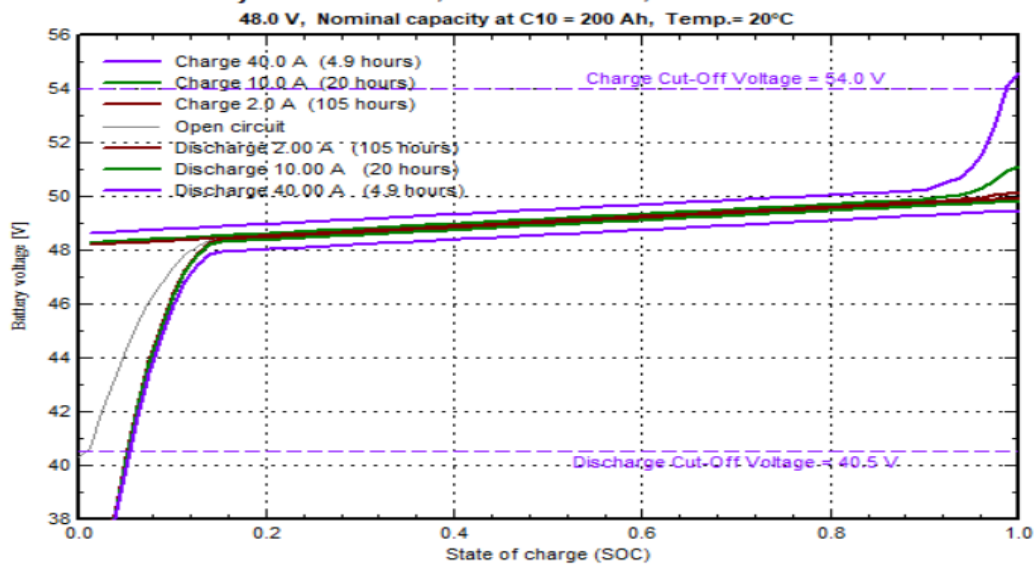

Figure 5. Voltage-SOC characteristics of the battery

Table 2. Proposed system general summary

Nb. of modules	Module area	Nb. of inverters	Battery Nominal Voltage	Nominal PV Power	Nominal AC Power	Pnom ratio
6	17m <sup>2</sup>	1	48.0 V	3.6 kWp	3.3 kWAC	1.081

The block diagram of the system is shown in Figure 2. PV panels are mounted on a standard container with dimensions of 3m in width and 7m in length (Type D, 3x7m), commonly used in our country (Tanyer, Tavukcuoglu, & Bekboliev, 2018). The primary purpose of the PV panels is to generate electricity energy to meet the energy demands of the users residing in the container. The energy provided from the PV panels is used both for consumption and for charging the battery storage system. During periods when the electricity generated by the PV panels is insufficient for immediate usage or when there is no solar energy generation (e.g., during nighttime), the system draws power from both the battery storage and the main electricity grid, as necessary, to meet the energy requirements of the users.

**Findings and Discussion**

The designed simulation was run with the values determined according to numerical calculations. The annual average performance rate of the system was found to be 82.3%. Normalized production values in the system and inverter and panel losses in the system are given in Figure 6. Average production value is calculated as 4.25 kWh/kWp/day per system. System loss was determined as 0.09 kWh/kWp on average per day and string loss was calculated as 0.61 kWh/kWp on average daily.

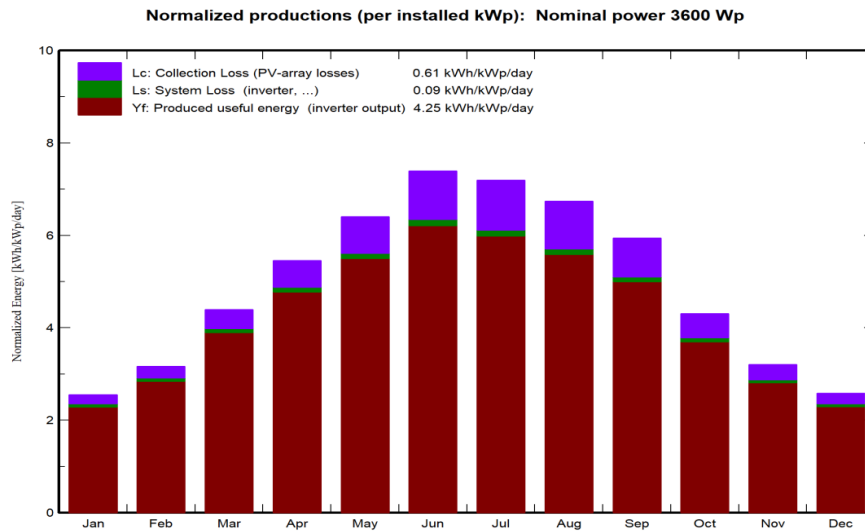

**Figure 6.** Normalized electricity generation and losses for the proposed model.

The system was exposed to about 1721 kWh/m<sup>2</sup> of global radiation. However, not all of this radiation can be utilized for energy production due to various losses: loss rate due to reflection is 2.8 %, panel weak light loss rate is 0.9%, panel temperature loss rate is 7.6%, panel mismatch loss is 1.1%, wiring loss is 1% and inverter loss is 2.1%. After accounting for these losses, the available energy at the inverter output is 5.59 MWh. 1.4% is lost in the batteries charging process of this energy. Additionally, 32.1% of the energy is stored in the batteries, while 67.9% is used directly.

For consumption, approximately 3.1% of the time, energy was met from the grid. In summary, the system is capable of producing a total of 5.36 MWh/year of energy, while the actual energy usage is 2.92 MWh/year. Fig. 7 illustrates the main results of the entire system and provides a summary of its performance throughout the year. The data shows that from April to October, the system did not rely on the grid for meeting its energy needs.

**Balances and main results**

	GlobHor	DiffHor	T_Amb	GlobInc	GlobEff	EArray	E_User	E_Solar	E_Grid	EFrGrid
	kWh/m <sup>2</sup>	kWh/m <sup>2</sup>	°C	kWh/m <sup>2</sup>	kWh/m <sup>2</sup>	kWh	kWh	kWh	kWh	kWh
January	69.9	36.26	9.35	79.1	75.5	263.1	247.8	223.7	12.7	24.04
February	81.0	42.27	11.15	88.7	85.6	294.5	223.8	206.8	61.6	17.00
March	128.6	62.89	14.52	136.2	132.2	445.1	247.8	246.7	167.7	1.03
April	158.3	78.31	17.82	163.6	159.3	527.5	239.8	239.8	258.1	0.00
May	196.2	87.96	22.20	198.6	193.9	626.7	247.8	247.8	349.2	0.00
June	220.8	74.54	26.04	221.7	216.9	685.2	239.8	239.8	415.8	0.00
July	221.5	77.97	29.15	223.0	218.0	682.1	247.8	247.8	404.2	0.00
August	203.1	67.40	29.79	208.8	204.1	636.8	247.8	247.8	358.7	0.00
September	167.8	48.26	26.45	178.3	173.8	551.3	239.8	239.8	281.7	0.00
October	121.9	50.40	22.31	133.4	129.1	422.6	247.8	247.8	145.3	0.00
November	83.6	30.58	16.04	96.1	92.1	311.2	239.8	227.1	56.1	12.67
December	68.4	30.09	11.14	80.1	76.0	263.3	247.8	221.8	13.4	25.91
Year	1721.2	686.93	19.71	1807.5	1756.5	5709.5	2917.1	2836.4	2524.5	80.64

**Legends**

GlobHor	Global horizontal irradiation	EArray	Effective energy at the output of the array
DiffHor	Horizontal diffuse irradiation	E_User	Energy supplied to the user
T_Amb	Ambient Temperature	E_Solar	Energy from the sun
GlobInc	Global incident in coll. plane	E_Grid	Energy injected into grid
GlobEff	Effective Global, corr. for IAM and shadings	EFrGrid	Energy from the grid

**Figure 7.** Summary of the proposed system performance

### Conclusion and Recommendations

In this study, we designed a grid-connected energy storage solar energy system. It is considered the average daily electrical energy requirement of a family of four residing in a container after an earthquake to be 8 kWh. Ensuring a safe, efficient, and sustainable energy supply for those staying in temporary shelters after natural disasters, such as earthquakes, is of critical importance in assisting emergency management efforts. Solar energy plays a crucial role in providing a secure and sustainable energy source in such shelters. Therefore, this study can serve as an exemplary model for meeting energy needs during emergency situations. Simulations made on a single container can be applied to larger scales.

When installing these systems in open areas with no obstructions like buildings or trees that could create shading, the efficiency of the solar panels will be high, as there won't be any shading on the panels. Moreover, the flat area on top of the container houses makes it advantageous for easy panel placement.

Since energy is stored in the system with batteries, it is important that the user's energy needs can be met with a hybrid system. Batteries reduce the dependency on the grid when the energy produced from the sun is insufficient. From April to October, the system was able to generate enough energy from the solar panels and stored the excess energy in batteries, allowing it to operate independently without drawing power from the grid. In this way, most of the energy is provided by energy obtained from renewable sources. In this way, sustainable and harmless to the nature (6,17 tons CO<sup>2</sup> emissions) are provided.

### References

- Dinçer, F. & Ozer, E. (2023). . Assessing the Potential of a Rooftop Grid-Connected Photovoltaic System for Gaziantep Islamic Science and Technology University/ Turkey. *Jordan Journal of Electrical Engineering*. Volume, 9(2), p.149-165. DOI: 10.5455/jjee.204-1670146602
- Kristiansen, A., Zhao, B., Ma, T., & Wang, R. (2021). The viability of solar photovoltaic powered off-grid Zero Energy Buildings based on a container home. *Journal of Cleaner Production*, 286, 125312.
- Mansur, T., Baharudin, N., & Ali, R. (2018). Design and Performance Analysis of Solar PV DC Power System for Disaster Relief Centre using PVsyst. Paper presented at the *Journal of Physics: Conference Series*. vol. 1019, no. 1: IOP Publishing, p. 012029.
- Presidency of the Republic of Türkiye Presidency of Strategy and Budget (SBB). (2023). 2023 Kahramanmaraş Ve Hatay Depremleri Raporu. Access Address (21.07.2023): <https://www.sbb.gov.tr/wp-content/uploads/2023/03/2023-Kahramanmaras-ve-Hatay-Depremleri-Raporu.pdf>
- Şahin, Z. R., Dincer, F. & Yılmaz, A.S. (2022). 4 Kişilik Bir Ailenin Elektrik Enerjisi İhtiyacı İçin Şebeke Bağlantılı Güneş Enerjisi Santrali Tasarımı Ve Simülasyonu. *Kahramanmaraş Sütçü İmam Üniversitesi Mühendislik Bilimleri Dergisi*, 25(Özel Sayı), 46-56.
- Tanyer, A. M., Tavukcuoglu, A., & Bekboliev, M. (2018). Assessing the airtightness performance of container houses in relation to its effect on energy efficiency. *Building and Environment*, 134, 59-73.



### DESIGN AND SIMULATION OF PHOTOVOLTAIC PANEL INTEGRATED WATER PUMPING SYSTEM: A CASE STUDY IN CEYHAN, ADANA CORN FIELD

**Emre ÖZER**

Öğr. Gör. Gaziantep İslam Bilim ve Teknoloji Üniversitesi, Gaziantep -Türkiye  
(Sorumlu Yazar) ORCID: 0000-0001-5881-2253

**Furkan Dinçer**

Doç. Dr., Kahramanmaraş Sütçü İmam Üniversitesi, Mühendislik ve Mimarlık Fakültesi, Elektrik-Elektronik Mühendisliği ,  
Kahramanmaraş -Türkiye, ORCID: 0000-0001-6787-0850

#### ABSTRACT

In this study, a photovoltaic water pumping system was designed and simulated. As the first step, the amount of water required for irrigation of the corn plant to be planted on one hectare of agricultural land in Ceyhan district of Adana province was determined. Then, the water to be used for irrigation was transferred to the tank through the pumping unit from the water channel near the field. Due to the high solar energy potential of the determined region, the energy requirement of the system was met by two panels with a nominal power of 260Wp. As a result of the simulation, the system worked effectively and the water requirement was met in May-August, when the plant needed water. These results show that the photovoltaic water pumping system can work efficiently and can be used as a sustainable energy source in agricultural irrigation.

#### FOTOVOLTAİK PANEL ENTEGRELİ SU POMPALAMA SİSTEMİ TASARIMI VE SİMÜLASYONU: CEYHAN, ADANA MISIR TARLASI ÖRNEĞİ

#### ÖZET

Bu çalışmada fotovoltaik su pompalama sistemi tasarımı ve simülasyonu yapılmıştır. İlk adımda Adana ili Ceyhan ilçesinde bir hektarlık tarım arazisine dikilecek mısır bitkisinin sulama için gerekli olan su miktarı belirlenmiştir. Daha sonra, sulamada kullanılacak su, tarla yakınındaki su kanalından pompalama ünitesi aracılığıyla tanka aktarılmıştır. Belirlenen bölgenin yüksek güneş enerjisi potansiyelinden dolayı sistemin enerji ihtiyacı 260Wp nominal güce sahip iki panelden sağlanmıştır. Yapılan simülasyon sonucunda bitkinin su ihtiyacının olduğu Mayıs –Ağustos aylarında sistem etkin bir şekilde çalışmış ve su ihtiyacı karşılanmıştır. Bu sonuçlar, fotovoltaik su pompalama sisteminin verimli bir şekilde çalışabileceğini ve tarım sulamasında sürdürülebilir bir enerji kaynağı olarak kullanılabileceğini göstermektedir.

**Anahtar Kelimeler:** Sulama, *fotovoltaik*, *pompalama*

#### Giriş

Tarım arazilerinin sulanması, verimliliğin ve sürdürülebilirliği artırılması için son derece önemlidir. Sulamanın tarımsal üretim üzerinde olumlu etkileri vardır. Fotovoltaik su pompalama sistemi, güneş enerjisiyle çalışan bir pompa sistemidir. Bu sistemler doğrudan güneş enerjisini kullanacaklarından fosil yakıtların kullanımını azaltan ve çevre dostu sistemlerdir. Ayrıca elektrik enerjisi şebekesine bağımlı olmadan doğrudan güneş enerjisiyle çalıştığından, enerji maliyetlerini düşürür. Özellikle uzak veya elektrik şebekesinin ulaşmadığı kırsal bölgelerde, güneş enerjisiyle çalışan pompalar ekonomiklik ve pratiklik sağlayacaktır (Aliyu ve ark. , 2018).

Türkiye’de Adana ilinde yer alan Ceyhan Nehri havzasındaki tarımsal alanlar geniş yer kaplamakta ve tarım arazilerine sulama kanalları yoluyla su iletimi yapılmaktadır. Bölgede buğday, yerfıstığı ve mısır gibi ürünlerin

tarımı yapılmaktadır. Ceyhan Kaymakamlığı (2023) sitesi incelendiğinde mısır (dane) en çok üretilen ürünlerden 2. sırada yer almaktadır.

Literatürde fotovoltaik su pompalama üzerine yapılmış çalışmalar bulunmaktadır. Bu çalışmalardan bazıları şu şekildedir; Sekmen ve ark. (2022) tarafından yapılan çalışmada Kayseri ilinin su ihtiyacının karşılanması için açılan kuyularda yaygın olarak kullanılan dalgıç pompaların enerjisinin şebekeden daha az enerji çekilerek fotovoltaik enerji kullanıp karşılanması amaçlanmıştır. Allumi ve ark.(2019) Fas'ta uzak bölgede bulunan evlerin su ihtiyacını karşılamak için PVsyst programıyla bir sistem tasarlamışlardır. Mohamed (2019) Somalide bulunan bir şehirdeki günlük 7,5 m<sup>3</sup> su kullanan küçük bir bahçenin su ihtiyacını karşılamak için bir sistem tasarlamıştır. Isak (2021) Güney Somali'de bir muz çiftliği sulamada kullanılmak üzere sistem tasarımı ve ekonomik değerlendirmesi yapmıştır.

### Materyal ve Metot

Şekil 1'de görüleceği üzere coğrafi koordinatları; Enlem: 37° 3' 29.20"K, Boylam: 35° 54' 12.49"D olan Adana ili Ceyhan ilçesinde yer alan bir tarım arazisi seçilmiştir. Arazi yol kenarında ve yola paralel sulama kanallarının hemen yanındadır. Kırmızı dikdörtgenle 1 hektar alan belirlenmiş ve bu alana mısır bitkisi dikilmesi düşünülmüştür. Belirlenen konuma ait Metenorm 8.1 veri tabanından oluşturulmuş aylık meteorolojik veriler Şekil 2'de görülmektedir. Yapılan tasarım belirlenen lokasyonun meteorolojik verileri dikkate alınarak gerçekleştirilmektedir.

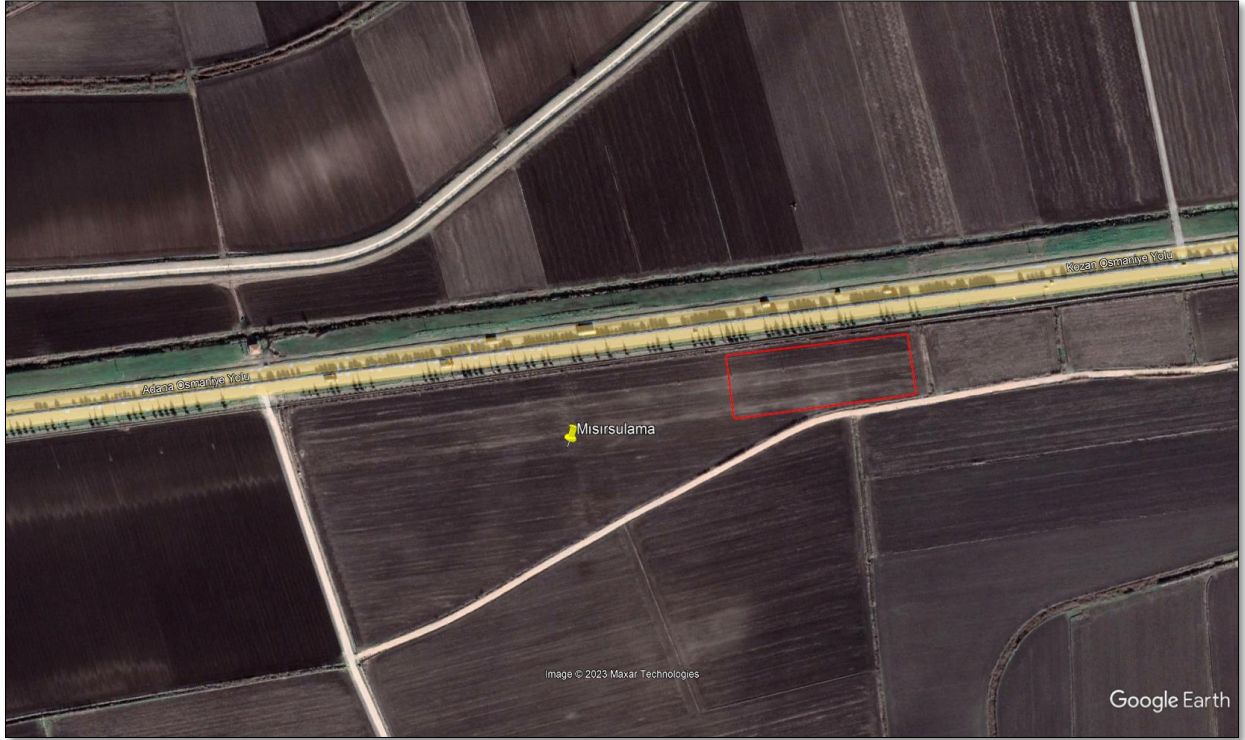

Şekil 1. Alan belirlenmesi ve seçimi

Konum		Hamdilli (Türkiye)				
Veri kaynağı		Meteonorm 8.1 (2006-2013), Sat=% 100				
	Global yatay ışınlama	Yatay difüz ışınlama	Sıcaklık	Rüzgar hızı	Linke bulanıklığı	Bağıl nem
	kWh/m <sup>2</sup> /ay	kWh/m <sup>2</sup> /ay	°C	m/s	[-]	%
Ocak	69.2	36.7	9.2	2.79	3.440	64.3
Şubat	81.7	43.1	10.9	2.70	3.807	64.5
Mart	129.3	65.3	14.3	2.70	4.411	63.1
Nisan	156.4	80.7	17.6	2.49	5.370	65.1
Mayıs	193.3	89.7	22.1	2.50	4.849	64.4
Haziran	220.0	79.6	25.9	2.70	4.200	64.6
Temmuz	221.6	76.6	29.1	2.79	4.395	65.7
Ağustos	200.8	76.7	29.7	2.60	4.451	64.7
Eylül	163.7	53.3	26.3	2.50	3.925	62.7
Ekim	119.6	51.3	22.2	2.40	3.999	55.3
Kasım	81.3	32.8	15.8	2.21	3.584	55.6
Aralık	67.6	30.3	10.9	2.60	3.373	62.7
<b>Yıl</b>	<b>1704.5</b>	<b>716.1</b>	<b>19.5</b>	<b>2.6</b>	<b>4.150</b>	<b>62.7</b>

Global yatay ışınlama yıldan yıla değişkenlik 4.5%

Şekil 2. Seçilen lokasyona ait aylık meteorolojik veriler

Mısır bitkisi Mart ayının ortalarında dikimi yapılan ve Ağustos ayında da hasadı yapılan bir bitkidir. Programda bitkilerin su ihtiyacı metreküp olarak girilmesi gerekmektedir. Bu sebeple (TAGEM,2017) tarafından çalışmadan bitkilerin sulama suyu ihtiyacı hesabı yapılabilir. Bu çalışmadaki verilerden mısıra ait bilgileri kullanılarak Tablo 1 oluşturulmuştur. Tablo 1’de Adana ilindeki istasyondan elde edilen mısır bitkisinin su tüketimi değerleri her ay için 10 günlük dönemler halinde verilmiştir. Ayrıca programa aylık değerler girileceğinden bu üç dönemin ortalaması hesaplanarak aylık ortalama değerler de belirlenmiştir. Görüleceği üzere bitki yaz ayları yoğun suya ihtiyaç duyar.

Tablo 1. Bitki su tüketimleri (mm) (TAGEM,2017,225)

Bitki	Aylar	I.dönem (mm)	II.dönem (mm)	III.dönem (mm)	Ortalama (mm)
Mısır (Dane)	Ocak	-	-	-	-
	Şubat	-	-	-	-
	Mart	-	6	13	6.3
	Nisan	14	17	25	18.7
	Mayıs	34	44	59	45.7
	Haziran	57	59	62	59.3
	Temmuz	63	56	43	54
	Ağustos	22	1	-	7.7
	Eylül	-	-	-	-
	Ekim	-	-	-	-
	Kasım	-	-	-	-
	Aralık	-	-	-	-

(TAGEM,2017,211) çalışmasında Ceyhan için ortalama yağış miktarları (mm) Tablo 2’de belirtilen değerler verilmiştir. Yaz aylarında yağışlar azalsa da yıl boyunca yağış görülmektedir.

Bitkinin su ihtiyacı bitki su tüketiminden ortalama yağış miktarı çıkarılarak bulunabilir. Buna göre Tablo 3’te aylık su ihtiyacı profili oluşturulmuştur. Burada (mm) ifadesi bir metrekarelik (m<sup>2</sup>) alana düşen yağış miktarını ifade eder. Çalışmada mısırın 1 hektar (10000 m<sup>2</sup>) alana dikildiği varsayıldığından tüm değerleri 10000 ile çarpılmalıdır. Aylık m<sup>3</sup> su ihtiyacı bulmak için bir metrekarelik (m<sup>2</sup>) alana düşen yağış miktarını temsil eden (mm) ifadesinin metreye dönüştürülmeli ve istenilen parsel alanı ile çarpılmalıdır. Örneğin 1 hektar mısır bitkisinin Mayıs ayında ihtiyaç duyduğu su ihtiyacı  $28 \text{ (mm)} = 0,028 \text{ (m)} * 10000 \text{ m}^2 = 280 \text{ m}^3$  şeklinde elde edilir. Tablo 3. de son sütunda sadece sulama yapılan zamanlar (mayıs-ağustos) düşünülerek su ihtiyacı hesaplanmış ve programa bu değerler girilmiştir.

**Tablo 2.** Ceyhan ortalama yağış miktarları (mm) (TAGEM,2017,211)

Aylar	I.dönem (mm)	II.dönem (mm)	III.dönem (mm)	Ortalama (mm)
Ocak	39	23	35	32.3
Şubat	34	42	26	34
Mart	28	26	28	27.3
Nisan	24	19	22	21.7
Mayıs	23	17	13	17.7
Haziran	7	12	5	8
Temmuz	2	2	3	2.3
Ağustos	-	3	2	1.7
Eylül	7	3	10	6.7
Ekim	10	19	21	16.7
Kasım	29	26	37	30.7
Aralık	27	58	38	41

**Tablo 3.** Aylık su ihtiyacı

Aylar	I.dönem (mm)	II.dönem (mm)	III.dönem (mm)	Ortalama (mm)
Ocak	-	32.3	-32.3	
Şubat	-	34	-34	
Mart	6.3	27.3	-21	
Nisan	18.7	21.7	-3	
Mayıs	45.7	17.7	28	280
Haziran	59.3	8	51.3	513
Temmuz	54	2.3	51.7	517
Ağustos	7.7	1.7	6	60
Eylül	-	6.7	-6.7	
Ekim	-	16.7	-16.7	
Kasım	-	30.7	-30.7	
Aralık	-	41	-41	



Sistemde önemli birleşenlerden birisi de pompa, su depolama tankı ve boru seçimine ait detayların belirlenmesidir. Şekil 3'te pompalama sistemine ait bilgiler görülmektedir. Programda kuyudan depoya ve göl veya akarsudan depoya şeklinde tanımlı iki sistem tipi seçeneği yer almaktadır. Göl veya akarsudan depoya sistem tipi seçilmiştir. Tasarlanan sistemde ekim alanının yakınında yer alan su kanallarındaki suyun polietilen (PE32) bir boru yardımıyla 10 metre ileriye taşınarak 100 m<sup>3</sup> hacimli bir tankı doldurduğu düşünülmüştür.

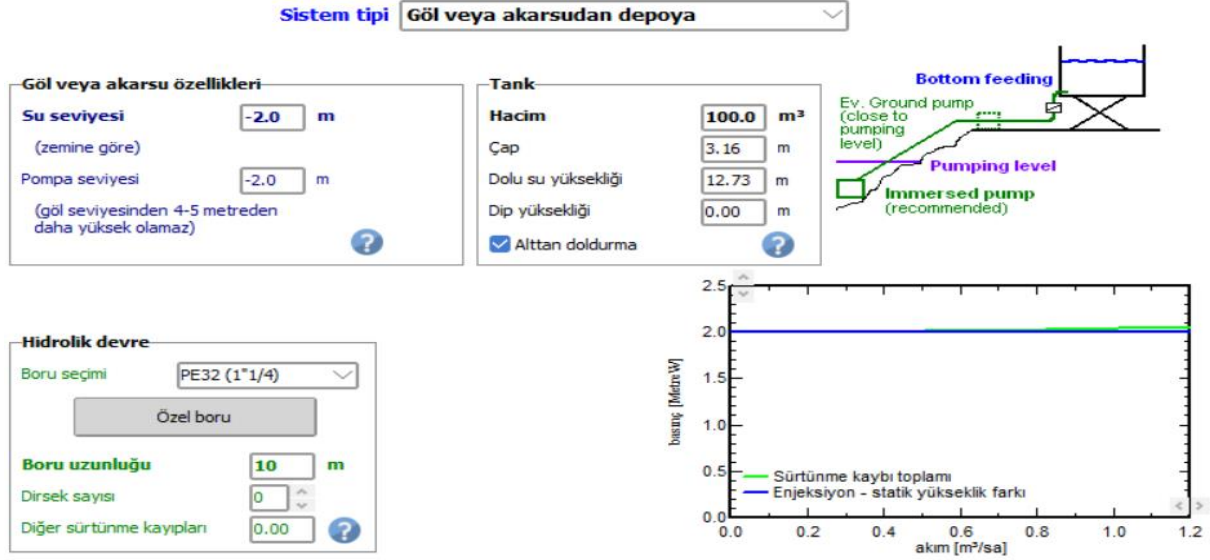

Şekil 3. Seçilen lokasyon için tasarlanan pompalama sistemi özellikleri

Kullanılan pompa, Lorentz marka 340 W maksimum güce ve 48 V nominal gerilime sahip MPPT dönüştürücülü fırçasız DC motordur. Hidrolik kısmı batık pompa tipi, ilerici boşluk pompa teknolojisine sahip, nominal çalışma basıncı 30 metreW ve buna tekabül eden akış 1.21 m<sup>3</sup>/sa'dır.

Seçilen fotovoltaik modüle ait bilgiler de Tablo 4'te gösterilmiştir. Sistemin elektrik enerjisi ihtiyacı paralel bağlı iki adet fotovoltaik panelden sağlanmaktadır. Panel düzleme 10° sabit bir açıyla yerleştirilmiştir. Tasarlanan sisteme ait bilgiler ise özet şeklinde Tablo 5'te verilmiştir. İhtiyaçtan fazla suyun sisteme pompalanması sebebiyle eksik su miktarı (-) olarak gösterilmiştir.

Tablo 4. Fotovoltaik modüle ait elektriksel özellikler

Özellik	Değeri
Üretici	ET Solar
Model numarası	ET-M660260WW
Teknoloji	Si-mono
Nominal Güç	260Wp
Açık devre voltajı	37.86 V
Kısa devre akımı	8.960 A
Panel sayısı	2
Yüzey alanı	3m <sup>2</sup>

Tablo 5. Önerilen sistemin özeti

Pompalanan Su	Su ihtiyacı	Eksik Su	Pompada Enerji	Kullanılmayan PV Enerji	Sistem verimliliği
1420m <sup>3</sup> /yıl	1370m <sup>3</sup> /yıl	% -3.6	200 kWh/yıl	561 kWh/yıl	% 24.5

### Sonuç ve Değerlendirme

Belirlenen tasarım için simülasyon gerçekleştirilmiş ve sistemin normalize üretim değerleri Şekil 4'te gösterilmiştir. Şekilden de görüleceği üzere sistemde tüm yıl boyunca elektrik enerjisi üretilebilmiştir. Ancak bu üretilen elektrik enerjisi yıl boyunca Ocak, Mayıs, Haziran, Temmuz ve Ağustos aylarında pompayı aktif hale getirerek kullanılmıştır. Ocak ayında tankı doldurmak için Mayıs, Haziran, Temmuz ve Ağustos aylarında da sulama yapıldığı için kullanılmıştır. Diğer aylarda depo dolu olduğundan kullanılmamıştır. Pompada etkin enerji 1,05 kWh/kWp/gün dür. Sistem kaybı günlük ortalama 0,11 kWh/kWp, dizi kaybı ise günlük ortalama 0,23 kWh/kWp olarak hesaplanmıştır.

Sistemin performansına ait sonuçlar Şekil 5'te gösterilmiştir. Pompanın çalıştığı zamanlarda sistem performansı görülmektedir. Tüm yıl boyunca performans oranı % 21.1 olarak hesaplanırsa da sulamanın en fazla olduğu Haziran ve Temmuz aylarında % 60 üzerinde performans görülmektedir.

Şekil 6'da tüm sisteme ait sonuçlar özet olarak gösterilmiştir. Toplam pompalanan su miktarı, toplam kullanılan su miktarından yıllık 50 m<sup>3</sup> fazladır. Sistemin su ihtiyacı karşılandığından yıl boyunca hiç su eksikliği yaşanmamıştır.

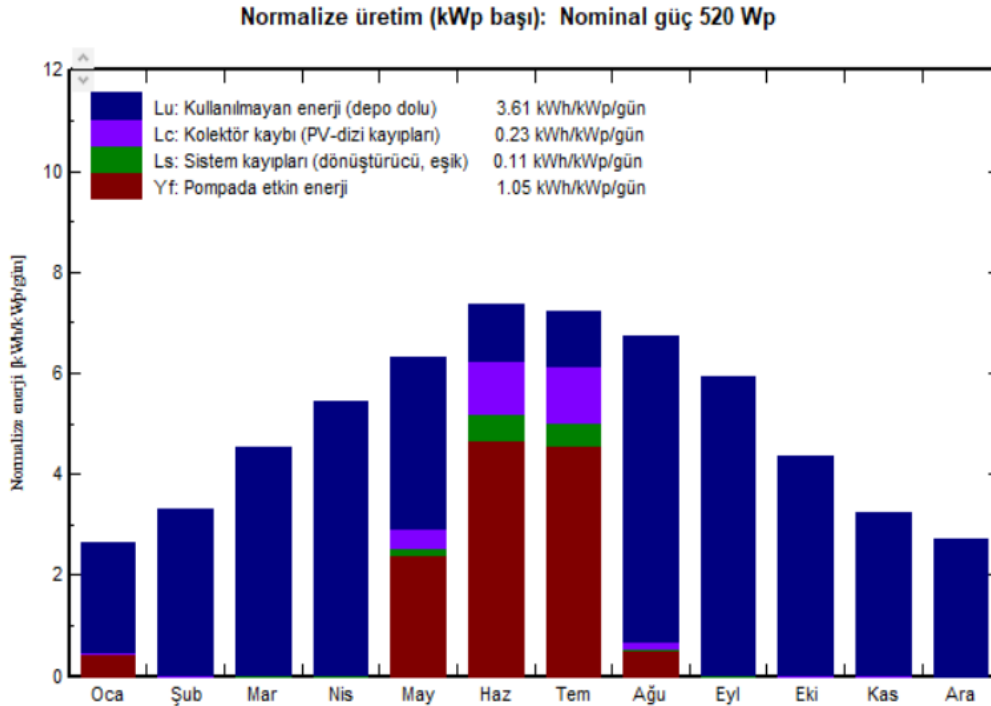

Şekil 4. Normalize edilmiş elektrik enerjisi üretimi ve kayıplar

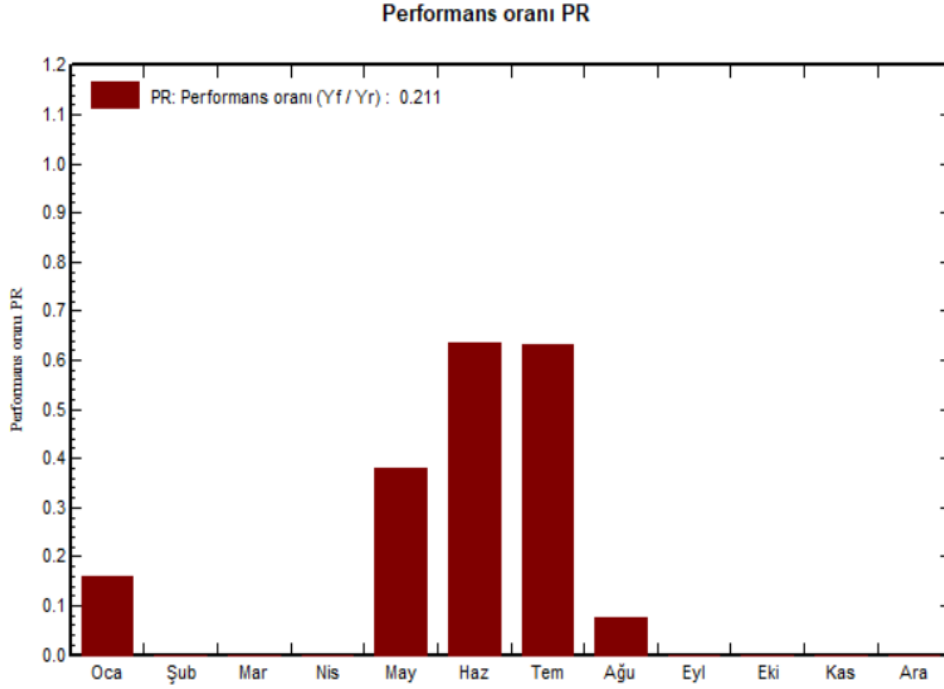

Şekil 5. Sisteme ait aylara göre performans Oranı

	GlobEff kWh/m <sup>2</sup>	EArrMPP kWh	E_PmpOp kWh	ETkFull kWh	H_Pump MetreW	WPumped m <sup>2</sup> /ay	W_Used m <sup>2</sup> /ay	W_Miss m <sup>2</sup> /ay
Ocak	78.7	40.13	6.90	31.54	2.060	50.0	0.0	0.000
Şubat	88.9	44.29	0.00	42.31	0.000	0.0	0.0	0.000
Mart	135.8	65.85	0.00	61.70	0.000	0.0	0.0	0.000
Nisan	158.6	75.11	0.00	69.73	0.000	0.0	0.0	0.000
Mayıs	190.9	87.51	38.57	41.98	2.059	278.1	280.0	0.000
Haziran	215.3	95.78	72.79	13.77	2.088	511.2	513.0	0.000
Temmuz	218.0	95.36	73.55	13.28	2.085	516.9	517.0	0.000
Ağustos	203.2	89.21	8.29	74.50	2.032	63.3	60.0	0.000
Eylül	172.6	77.32	0.05	71.69	2.021	0.4	0.0	0.000
Ekim	130.8	61.12	0.00	58.39	0.000	0.0	0.0	0.000
Kasım	93.4	45.57	0.00	43.65	0.000	0.0	0.0	0.000
Aralık	79.9	40.36	0.00	38.70	0.000	0.0	0.0	0.000
Yıl	1766.0	817.61	200.13	561.22	2.075	1420.0	1370.0	0.000

**Açıklama**

GlobEff IAM ve gölgeleme için düzeltilmiş etkin Global

EArrMPP MPP'de varsayılan dizi enerjisi

E\_PmpOp Pompa çalışma enerjisi

ETkFull Kullanılmayan enerji (depo dolu)

H\_Pump Pompadaki ortalama toplam basınç

WPumped Pompalanan su hacmi

W\_Used Tüketilen su

W\_Miss Eksik su

Şekil 6. Sisteme ait genel sonuçlar

Bu çalışmada 1 hektar alana dikilen mısır bitkisinin sulanması için fotovoltaik sulama sistemi PVsyst demo programında tasarlanmıştır. Çalışma fotovoltaik panel sistemi kullanılarak tarımsal sulama yapmayı amaçlayan araştırmacılar için literatürde Türkçe bir kaynak olması açısından önemlidir. Mısır bitkisinin suya en fazla ihtiyaç duyduğu zamanlar aynı zamanda güneş enerjisi içinde yoğun ışımının gerçekleştiği zamanlardır. Bu sebeple sulama, fotovoltaik sisteminden elde edilen elektrik enerjisiyle kolaylıkla sağlanabilir.

Çalışmada kullanılan bitki özellikle yaz aylarında su ihtiyacı yüksek olan bir bitkidir ancak su ihtiyacı farklı zaman dilimi olan bitkiler için ya da daha büyük ölçekli alanların sulanması için yapılacak çalışmalarda bu çalışma örnek olarak alınabilir. Sistemde tüm yıl boyunca üretilen enerjinin büyük miktarı (%68.6'sı) kullanılmadığından, bu enerjinin kullanılması durumunda yıl boyunca sulamalı tarıma imkân sağlanır.

İki adet nominal gücü (260Wp) yüksek olmayan panel kullanılarak tüm sulama ihtiyacı karşılandığından fotovoltaik sistemi kurulum maliyeti çok yüksek olmayacaktır. Ayrıca panellerin 3 m<sup>2</sup> bir alanı kullanması tarımsal arazinin daha fazla kullanılabilmesine olanak tanır.

### Kaynaklar

Aliyu, M., Hassan, G., Said, S. A., Siddiqui, M. U., Alawami, A. T., & Elamin, I. M. (2018). A review of solar-powered water pumping systems. *Renewable and Sustainable Energy Reviews*, 87, 61-76.

Allouhi, A., Buker, M., El-Houari, H., Boharb, A., Amine, M. B., Kousksou, T., & Jamil, A. (2019). PV water pumping systems for domestic uses in remote areas: Sizing process, simulation and economic evaluation. *Renewable Energy*, 132, 798-812.

Ceyhan Kaymakamlığı. (2023). Tarım ve Hayvancılık. Erişim adresi (03.08.2023):<http://ceyhan.gov.tr/tarim>

Mohamed A. A. (2019). Somaliland'da fotovoltaik su pompalama sistemlerinin tasarımı ve boyutlandırması., Fen Bilimleri Enstitüsü, İzmir, Türkiye.

Isak, A. M. (2021). Güneş Enerjili Su Pompalama Sistem Tasarımı: Somali Örneği. Fen Bilimleri Enstitüsü, Konya, Türkiye.

Sekmen, U., Yıldız, O. F., Yılmaz, M., & Ozdemir, O. (2022). Using solar photovoltaic energy in urban water supply systems: a case study in Kayseri, Turkey. *Journal of Water and Climate Change*, 13(5), 2048-2069.



## A POWER QUALITY CLASSIFICATION METHOD BASED ON XGBOOST

**Oğuzhan KATAR**

Research Assistant, Firat University, Faculty of Technology, Department of Software Engineering, Elazığ-Türkiye  
(Responsible Author) ORCID: 0000-0002-5628-3543

**Özal YILDIRIM**

Assoc. Prof., Firat University, Faculty of Engineering, Department of Artificial Intelligence and Data Engineering, Elazığ-Türkiye  
ORCID: 0000-0001-5375-3012

### ABSTRACT

In today's rapidly evolving industrial landscape, ensuring the uninterrupted quality of electrical power has emerged as a paramount concern due to the potential for power quality issues such as voltage sags, surges, harmonics, and flicker. These issues can inflict damage upon equipment and disrupt operations, emphasizing the critical importance of detecting power quality problems. The power quality detection has predominantly relied on manual methods, often involving visual inspection of waveforms on oscilloscopes and the use of handheld meters to measure voltage and current characteristics. However, manual classification of power quality is prone to human error and is a time-consuming process. This paper proposes an XGBoost-based method for the automatic detection of five different power quality classes based on signal data. In this proposed method, the signal data is divided into 128 data points, with each point defined as a feature of the dataset. Pre-processing steps such as Fourier transform and normalization were applied to the dataset samples. The model is then trained using the five-fold cross-validation method and its performance is validated on each test set. Remarkably, the proposed XGBoost-based method demonstrated exceptional performance, achieving 100% classification accuracy across all five distinct test sets. This outcome signifies its potential as a robust and reliable solution for automated power quality assessment in today's dynamic industrial landscape.

**Keywords:** Power quality, XGBoost, Signal classification, Automatic detection.

### Introduction

Electrical power quality is a critical aspect of electrical power that ensures the effective and efficient operation of electrical equipment (Kumar et al., 2017). With the increasing reliance on electronic devices and sensitive equipment, maintaining high power quality is crucial in preventing operational disruptions, equipment damage, and financial losses (Khan et al., 2023). Power quality issues manifest as voltage fluctuations, harmonic distortions, transients, flicker, and other deviations from the ideal sinusoidal waveform (Mahfoud et al., 2019). The effects of inadequate power quality extend to various domains, including industrial processes, commercial operations, and residential environments. In industrial environments, power quality problems can result in significant production losses, while in the healthcare sector, a flawless power supply is indispensable for accurate medical diagnosis and patient safety (Bajaj & Singh, 2020). Therefore, it is imperative to address power quality issues to prevent significant consequences.

Industries highly value consistent power quality to ensure unbroken production processes, minimize downtime, and optimize overall efficiency (Sinwar et al., 2023). The maintenance of sensitive electrical equipment is of utmost importance, and achieving optimal power quality is crucial for achieving this. Voltage fluctuations and harmonics are potential anomalies that can lead to premature failures and operational disruptions (Zjavka, 2023). To evaluate power quality, one fundamental method is voltage and current waveform analysis. This involves analyzing the characteristics of voltage and current waveforms, including their shape, magnitude, and timing, to identify deviations from the ideal sinusoidal pattern (Sanjan et al., 2020).

The utilization of manual voltage and current waveform analysis has inherent limitations due to human errors, such as misinterpretations, miscalculations, and oversight, which can lead to inaccuracies in identifying flaws and suggesting system modifications. The processing speed constraints of manual analysis can result in

bottlenecks and extended system downtime, particularly in situations requiring swift responses. The challenge is further compounded when dealing with extensive datasets, as professionals may struggle to extract essential insights from vast amounts of information. Moreover, the absence of continuous monitoring inherent in manual analysis can result in blind spots, allowing transient events to go unnoticed and potentially escalate into more significant issues. However, the integration of artificial intelligence (AI) into this process offers numerous benefits that significantly enhance the accuracy, speed, and cost-effectiveness of waveform analysis (Mishra, 2019).

AI-powered waveform analysis provides a higher level of accuracy and consistency compared to human operators (Ozcanli et al., 2020). Human operators may be prone to fatigue, distraction, or biases that can impact the interpretation of waveforms. AI, on the other hand, remains consistently vigilant and objective, eliminating the risk of human-related errors. This leads to more precise fault diagnosis, reducing false positives and negatives, and ultimately minimizing unnecessary maintenance and repairs. Given these advantages, the exploration of AI-based automatic electrical power quality detection remains an active research field.

Ma et al. proposed the use of stacked autoencoder for power quality classification (Ma et al., 2017). The proposed method achieved 99.75% accuracy in classifying 7 different types of power quality. Wang et al. proposed a 1D convolutional neural network (CNN) model for the detection of power quality disturbances (Wang & Chen, 2019). The proposed deep model can extract features automatically without the need for manual feature extraction. The model achieved 99.96% accuracy on 16 different power quality classes in the test phase. Mohan et al. proposed a hybrid model for power quality classification (Mohan et al., 2017). The hybrid model, created by combining CNN and LSTM, achieved an accuracy rate of 91.90%. Sindi et al. proposed a hybrid model based on 1D and 2D CNN to classify power quality (Sindi et al., 2021). In their proposed method, firstly, 1D power signals are processed in 1D CNN model. Then, these signals are directly converted into images and processed in the 2D CNN model. The features from both CNN models are combined and classified with the help of a fully connected layer. The proposed method achieved 99.97% accuracy rate in the test phase.

While CNN-based methods have achieved notable success in automatic power quality classification studies, their effectiveness relies on ample labeled data, which can be a challenge in domains with limited annotated information, such as signal detection. This scarcity of data significantly limits their practicality. Additionally, the substantial parameter count within CNNs contributes to increased computational requirements during the critical feature extraction process, making real-time systems with lighter computational capabilities a challenge. As a result, classical machine learning methods are emerging as potentially more efficient alternatives for power quality classification.

In this study, an XGBoost classifier model was utilized to classify power quality signals. Initially, the dataset samples underwent a Fourier transform (FT) and were subsequently normalized using the StandardScaler function. The performance of the model was evaluated through a 5-fold cross-validation method.

The primary contributions of this research can be summarized as follows:

- The application of pre-processing techniques, including FT and normalization, enabled the dataset samples to be compatible with classification models.
- The XGBoost classifier utilized only 128 data points from each signal as features.
- The model achieved significant performance levels with a low training cost for power quality classification.
- The robustness of the proposed method was validated through a 5-fold cross-validation process.

## Materials and Methods

This paper presents a model for automatic classification of power quality using XGBoost, which involves the extraction of 128 data points from signals as features to be processed. The method includes preprocessing techniques such as FT and normalization, followed by the division of preprocessed samples into training and testing sets. The model is trained on a dataset of 9,599 samples and assessed through predictions on test data, with the process repeated across five folds. The proposed method is illustrated in Figure 1.

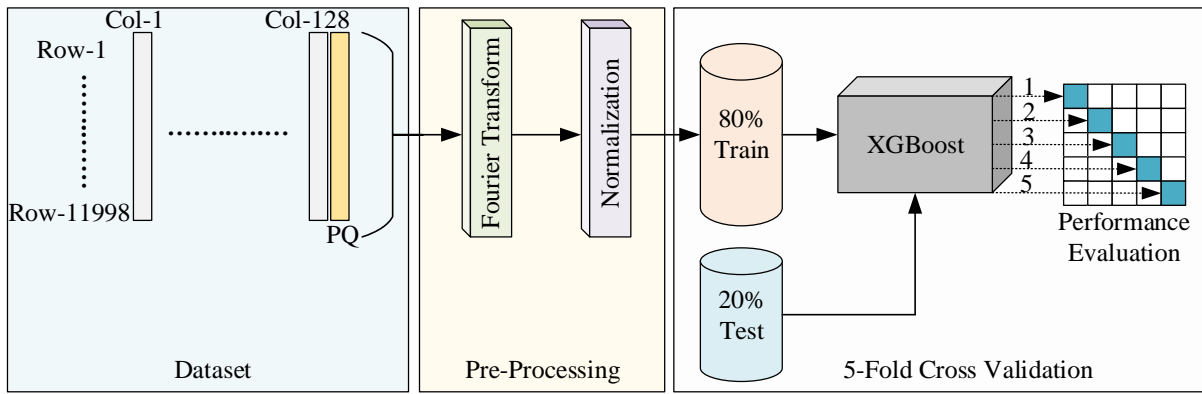

Figure 1. The proposed method

**Dataset**

In this study, we employed a public dataset containing 11,998 samples (Power Quality Classification Dataset - 1, 2021). Each signal in the dataset was characterized by 128 features, and the final column indicated the quality scale of the signal. The dataset consisted of 129 columns in total, and five distinct quality labels were present. The quality scale ranged from 1 to 5, with 1 representing the highest quality power signal and 5 denoting the lowest. Illustrative samples of each category within the dataset were provided in Figure 2.

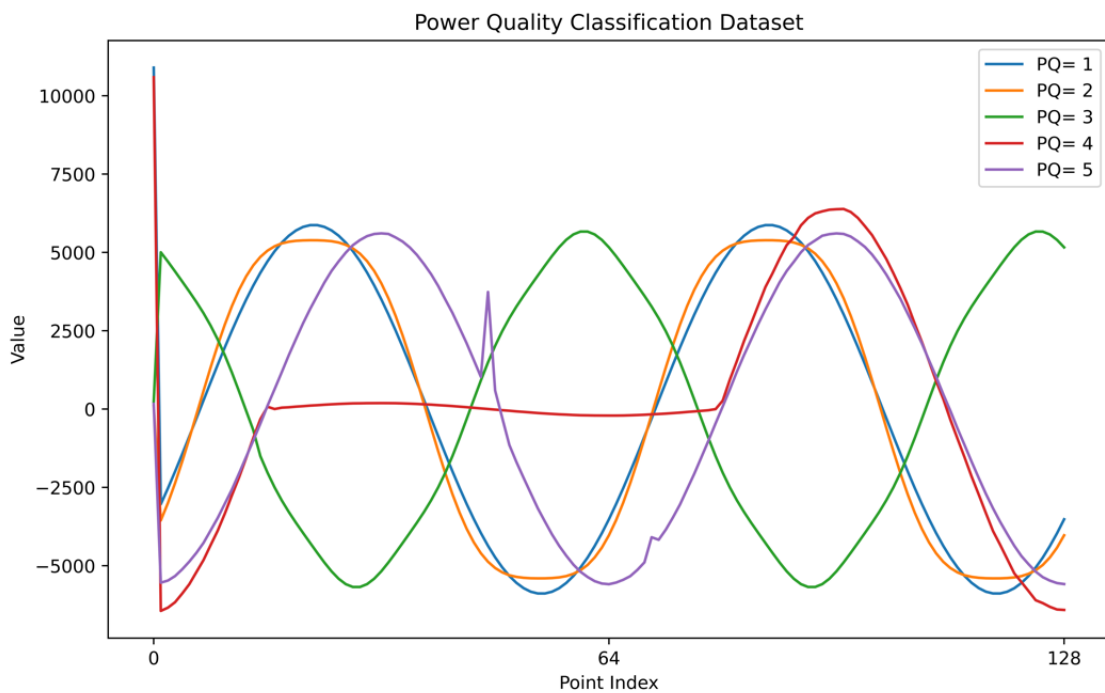

Figure 2. Dataset samples

128 features are extracted from each signal and recorded in a CSV file. Each line in the CSV file corresponds to a signal, and the expert labels the classes to which the signals belong. Figure 3 illustrates the process of creating a CSV row from a signal.

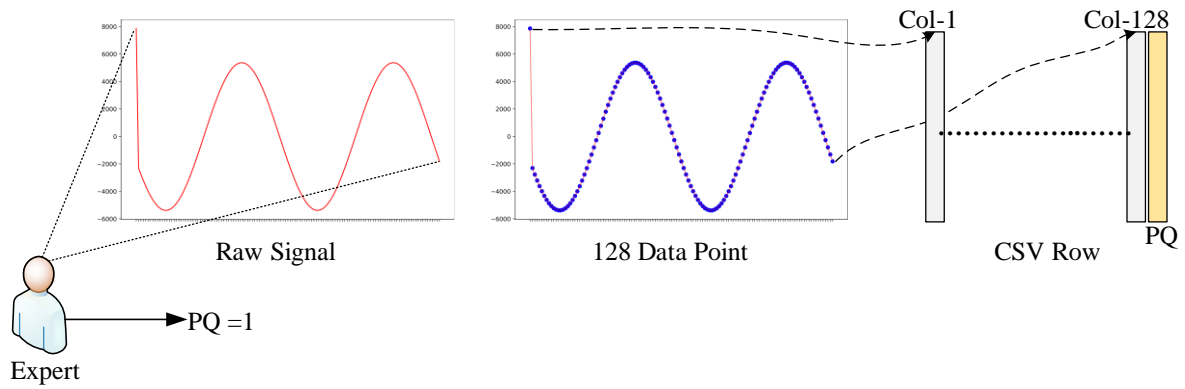

Figure 3. Extraction of signal features

The dataset exhibits imbalanced distribution as the number of samples belonging to classes 3 and 5 is greater than those in other classes. The class distribution graph of the samples in the dataset is given in Figure 4.

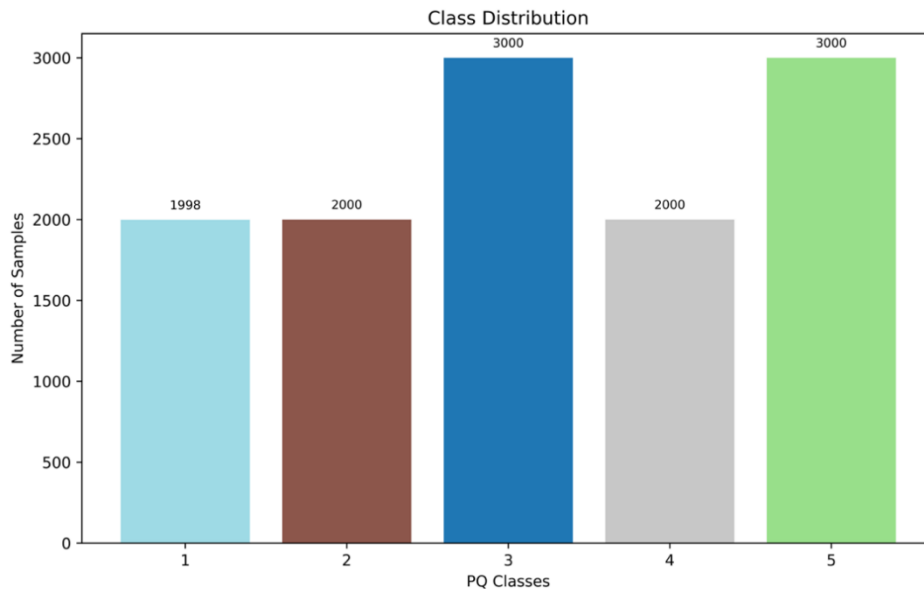

Figure 4. Distribution of dataset

In certain instances where the distribution of classes is imbalanced, the training process of a machine learning model can be faced with several challenges. This is often caused by the limited number of instances belonging to minority classes, which results in a bias towards the majority class. This inclination can lead to a decrease in the overall classification accuracy. To address this issue, data augmentation techniques can be employed. However, in the context of this study, data augmentation was intentionally excluded. The purpose was to evaluate the performance of the XGBoost model under the demanding conditions posed by class imbalance.

### Classifier Model

Ensemble learning method eXtreme Gradient Boosting (XGBoost) is a highly effective and powerful model for structural data analysis. As a tree-based model, XGBoost strives to enhance its predictive capabilities through the reinforcement of weaker predictions (Chen et al., 2015). The fundamental strategy utilized by XGBoost is depicted in Figure 5.



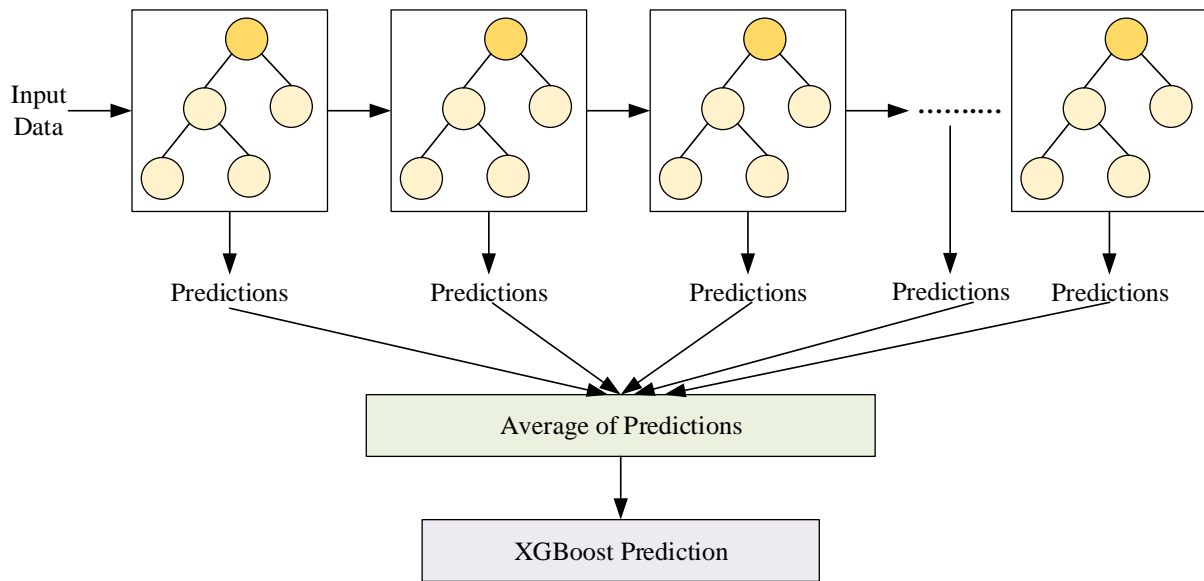

**Figure 5.** XGBoost architecture

XGBoost is a powerful machine learning model known for its high performance, scalability, fast training processes, and unbalanced data handling capabilities. Its key features include regularization mechanisms, fast learning algorithms, and the ability to handle special loss functions. The hyper-parameters used in this study are listed in Table 1.

**Table 1.** The hyperparameters of XGBoost

Parameter	Value
Learning Rate	0.1
Number of Estimators	100
Maximum Depth	3
Minimum Child Weight	1
Gamma	0
Eval Metric	Log Loss

**Performance Evoulation**

The dataset samples are divided into five equal parts with random samples to be used in the model training and testing phase. Each of the divided parts is called a fold. Each fold is used as test data in turn, while the other four folds are combined and used as training data. In this case, the first fold is used as test data, while the other four folds are combined to train the model and the performance of the first fold is evaluated. This process is repeated five times, each time a different fold is used as test data. In this way, each fold is used as both test and training data to evaluate how the model performs on the whole dataset. The block representation of the method used for separating the dataset samples as training and test is given in Figure 6.

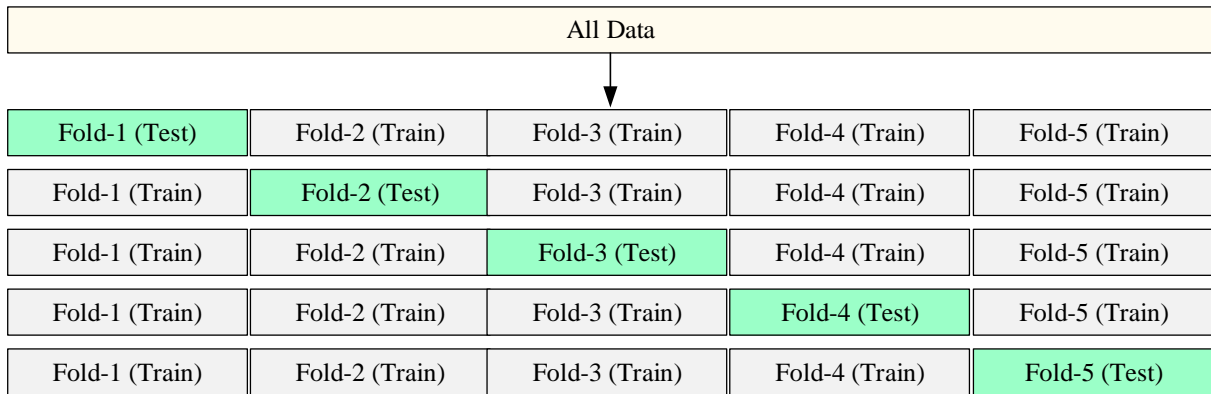

Figure 6. 5-Fold Cross Validation

To evaluate the performance of the model, predictions are made on each test fold. These predictions are placed in a table called a confusion matrix and various performance measures are calculated. Confusion matrices are a fundamental tool for evaluating the performance of classification models. These matrices provide a detailed analysis of the predictions made by the model against the true ground truth labels. In classification studies, the confusion matrix consists of four basic metrics: true positives (TP), true negatives (TN), false positives (FP) and false negatives (FN). The areas represented by the TP, TN, FP and FN metrics on the confusion matrix in a 5-class classification scenario are given in Figure 7.

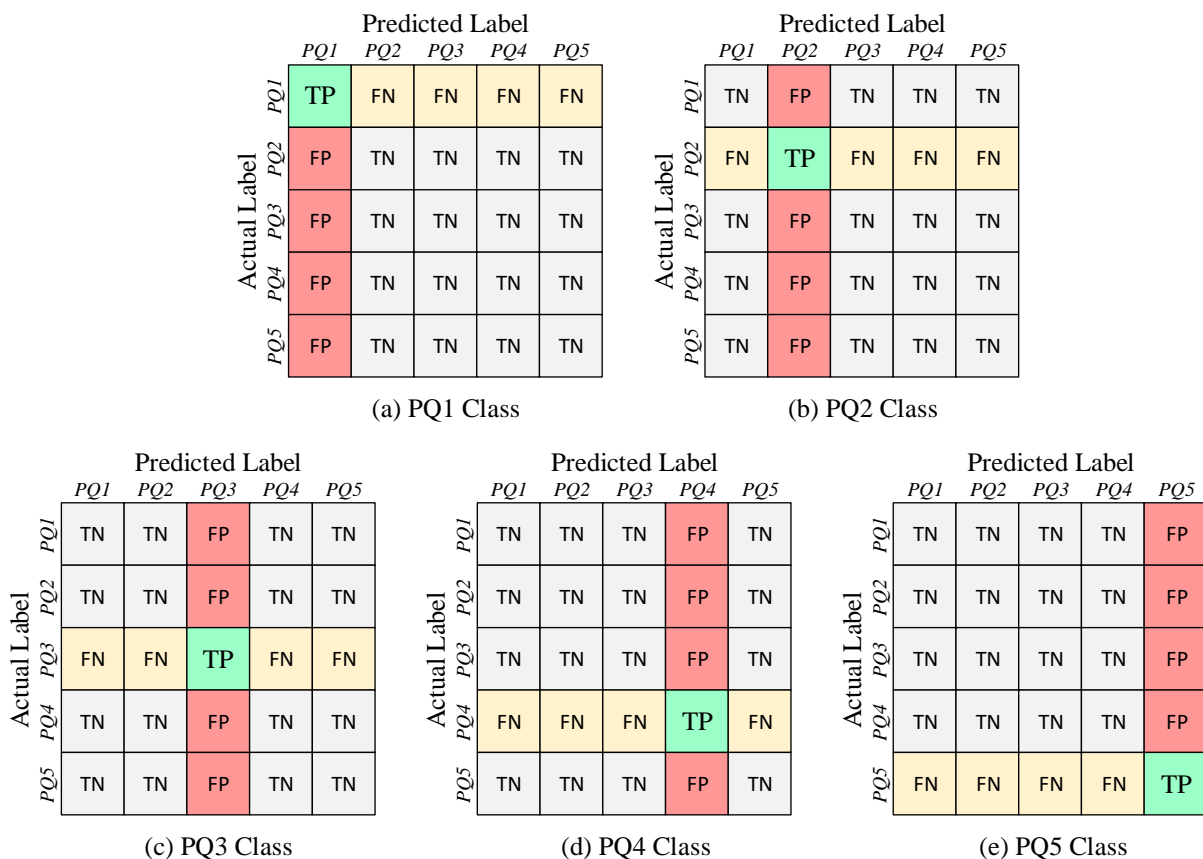

Figure 7. The confusion matrix in a 5-class scenario

Using these four criteria, statistical measures can be utilized to ascertain the efficacy of the classifier models. These performance measures and equations are summarized in Table 2.

**Table 2.** Performance measures and equations

Measures	Description	Equation
Accuracy (Acc)	The ratio of correct predictions to all predictions.	$\frac{TP + TN}{TP + FP + FN + TN}$
Precision (Pre)	The ratio of positive predictions to actual positives.	$\frac{TP}{TP + FP}$
Sensitivity (Sen)	The rate of accurately predicted true positives.	$\frac{TP}{TP + FN}$
Specificity (Spe)	The rate of accurately predicted true negatives.	$\frac{TN}{TN + FP}$
F-1 Score	The harmonic mean of Pre and Sen.	$\frac{2 * (Pre * Sen)}{(Pre + Sen)}$

**Results**

The XGBoost classifier was trained on the train set and subsequently utilized for predicting the power quality classes of the test set that it had not encountered during the training phase. This procedure was repeated five times, with each iteration involving the use of five distinct training and test folds. The confusion matrices obtained from each of these test folds are same and are depicted in Figure 8.

**Fold-1 to Fold-5**

	PQ1	PQ2	PQ3	PQ4	PQ5
PQ1	380	0	0	0	0
PQ2	0	399	0	0	0
PQ3	0	0	631	0	0
PQ4	0	0	0	378	0
PQ5	0	0	0	0	612

**Figure 8.** Test folds predictions

The proposed method demonstrated highly effective results in the power quality detection task, achieving a strong classification capability. Our model correctly classified all five classes, as confirmed by the confusion matrix analysis, which showed that the model provided high accuracy and classification ability. The ratios of other performance metrics are presented in Table 2.

**Table 2.** Test results

Test Fold	PQ1			PQ2			PQ3			PQ4			PQ5		
	Pre	Rec	F-1	Pre	Rec	F-1	Pre	Rec	F-1	Pre	Rec	F-1	Pre	Rec	F-1
Fold-1	100%	100%	100%	100%	100%	100%	100%	100%	100%	100%	100%	100%	100%	100%	100%
Fold-2	100%	100%	100%	100%	100%	100%	100%	100%	100%	100%	100%	100%	100%	100%	100%
Fold-3	100%	100%	100%	100%	100%	100%	100%	100%	100%	100%	100%	100%	100%	100%	100%
Fold-4	100%	100%	100%	100%	100%	100%	100%	100%	100%	100%	100%	100%	100%	100%	100%
Fold-5	100%	100%	100%	100%	100%	100%	100%	100%	100%	100%	100%	100%	100%	100%	100%

## Conclusions

This paper focuses on the development and evaluation of a model for power quality classification. The results obtained using the XGBoost algorithm provide important findings. Firstly, the data preprocessing steps of Fourier Transform (FT) and normalization helped to process the signals efficiently. These preprocessing steps enabled 128 feature points to be given as input to any machine learning classifier. The obtained data was split into training and test datasets and the XGBoost model was trained. The training dataset contained 9,599 samples and the success of the model was evaluated on the test data. This process was repeated with five different layers of cross-validation. In this way, the reliability and generalisation ability of the model were robustly measured. The proposed method showed 100% accuracy on each test fold, and other performance metrics conclusively show that the method has a strong classification performance. This study has developed a powerful classification model that can be used as an important tool for power quality monitoring and assessment. Future studies with larger data sets and different signal types can contribute to the advancement of research in this field.

## References

- Bajaj, M., & Singh, A. K. (2020). Grid integrated renewable DG systems: A review of power quality challenges and state-of-the-art mitigation techniques. *International Journal of Energy Research*, 44(1), 26–69.
- Chen, T., He, T., Benesty, M., Khotilovich, V., Tang, Y., Cho, H., Chen, K., Mitchell, R., Cano, I., & Zhou, T. (2015). Xgboost: extreme gradient boosting. *R Package Version 0.4-2*, 1(4), 1–4.
- Khan, S. U., Mynuddin, M., Ahad, D. M. A., Hossain, M. I., Islam, M. J., & Kabir, M. F. (2023). A Comparative Analysis of Deep Learning Models for Power Quality Disturbance Classification. *2023 IEEE World AI IoT Congress (AIIoT)*, 317–323.
- Kumar, D., Zare, F., & Ghosh, A. (2017). DC microgrid technology: system architectures, AC grid interfaces, grounding schemes, power quality, communication networks, applications, and standardizations aspects. *Ieee Access*, 5, 12230–12256.
- Ma, J., Zhang, J., Xiao, L., Chen, K., & Wu, J. (2017). Classification of power quality disturbances via deep learning. *IETE Technical Review*, 34(4), 408–415.
- Mahfoud, F. Y., Guzun, B. D., Lazaroiu, G. C., & Alhelou, H. H. (2019). Power quality of electrical power systems. In *Handbook of research on smart power system operation and control* (pp. 265–288). IGI Global.
- Mishra, M. (2019). Power quality disturbance detection and classification using signal processing and soft computing techniques: A comprehensive review. *International Transactions on Electrical Energy Systems*, 29(8), e12008.
- Mohan, N., Soman, K. P., & Vinayakumar, R. (2017). Deep power: Deep learning architectures for power quality disturbances classification. *2017 International Conference on Technological Advancements in Power and Energy (TAP Energy)*, 1–6.
- Ozcanli, A. K., Yaprakdal, F., & Baysal, M. (2020). Deep learning methods and applications for electrical power systems: A comprehensive review. *International Journal of Energy Research*, 44(9), 7136–7157.

- Power Quality Classification Dataset - 1. (2021). Power Quality Classification Dataset - 1 | Kaggle. <https://www.kaggle.com/datasets/jaideepreddykotla/powerqualitydistributiondataset1>
- Sanjan, P. S., Gowtham, N., Bhaskar, M. S., Subramaniam, U., Almakles, D. J., Padmanaban, S., & Yamini, N. G. (2020). Enhancement of power quality in domestic loads using harmonic filters. *IEEE Access*, 8, 197730–197744.
- Sindi, H., Nour, M., Rawa, M., Öztürk, Ş., & Polat, K. (2021). A novel hybrid deep learning approach including combination of 1D power signals and 2D signal images for power quality disturbance classification. *Expert Systems with Applications*, 174, 114785.
- Sinwar, D., Muduli, K., Dhaka, V. S., & Singh, V. (2023). *Computational Intelligence based Optimization of Manufacturing Process for Sustainable Materials*. CRC Press.
- Wang, S., & Chen, H. (2019). A novel deep learning method for the classification of power quality disturbances using deep convolutional neural network. *Applied Energy*, 235, 1126–1140.
- Zjavka, L. (2023). Power quality daily predictions in smart off-grids using differential, deep and statistics machine learning models processing NWP-data. *Energy Strategy Reviews*, 47, 101076.



### PIROLİZ YAĞININ OTOMOTİV MALZEMELERİ ÜZERİNDEKİ MEKANİK VE KOROZİF ÖZELLİKLERİNİN ARAŞTIRILMASI

**Özgür BEDER**

Ondokuzmayıs Üniversitesi, Mühendislik Fakültesi, Makine Mühendisliği Bölümü, Samsun-Türkiye,  
(Sorumlu Yazar) ORCID: <https://orcid.org/0000-0002-6565-7674>

**Hakan ÖZCAN**

Prof. Dr. Ondokuzmayıs Üniversitesi, Mühendislik Fakültesi, Makine Mühendisliği Bölümü, Samsun-Türkiye  
ORCID: <https://orcid.org/0000-0002-7848-3650>

#### ÖZET

Biyodizel yakıtlar, setan sayılarının yüksek olması, parlama noktası sıcaklıklarının düşük olması gibi bir takım avantajları ile ön plana çıkmaktadırlar. Bununla birlikte, biyodizel veya biyodizel yakıt karışımlarının motor materyalleri üzerindeki korozi etkisi ise üzerinde çokça çalışılan dezavantajlarından olmaya devam etmektedir. Literatürde yapılan çalışmalar incelendiğinde; özellikle yakıtla temas eden yüzeyleri başta olmak üzere, biyodizel maruz bırakılan motorda kullanılan materyallerin korozyon süreçlerini irdeleyen ve bu materyallerin biyodizel maruz kaldıktan sonra mekanik özelliklerinde ve yakıt özelliklerinde meydana gelen değişiklik süreçlerini konu edinen çalışmaların azınlığı ve eksikliği dikkat çekmektedir. Tüm bu nedenlere dayanarak çalışmamızda, atık lastik piroliz yağı temin edilmiş ve dizel yakıt ile; hacimsel olarak % 0, % 10, % 20 ve % 100 oranlarında karıştırılarak K 0, K 10, K 20 ve K 100 şeklinde adlandırılan karışımlar elde edilmiştir. K 0 karışımı, % 0 atık lastik piroliz yağı içeren saf motorin, K 100 karışımı % 100 atık lastik piroliz yağı içeren saf atık lastik piroliz yağıdır. Elde edilen tüm yakıt karışımları ASTM standartları uyarınca analiz edilmiştir. Otomobil materyallerinden pirinç, paslanmaz çelik ve alüminyum alaşım; farklı oranlarda karıştırılarak elde edilmiş olan pirolize lastik yağı-dizel yakıt karışımlarına statik daldırma yöntemi ile maruz bırakılmış ve akabinde korozyon özellikleri tespit edilmiştir. ASTM standartlarına göre yapılan bu korozyon analizi öncesi ve sonrasında materyallerin mekanik özellikleri tespit edilmiştir. Yine çalışmamıza konu otomobil materyallerinin yüzeylerindeki morfolojik değişimler de incelenmiştir. Çalışmamızda, 1440 saat (60 Gün) boyunca değişik oranlarda hazırlanmış yakıt karışımlarımıza statik daldırma yöntemi ile maruz kalmış olan pirinç, paslanmaz çelik ve alüminyum alaşımlarda dikkat çeken sonuçlar elde edilmiştir. K 100'e maruz kalan pirinç materyaldeki korozyon oranı (0,102 mpy), K 0'a maruz kalan pirinç materyaldeki korozyon oranından (0,042 mpy) çok daha yüksek bulunmuştur. K 100'e maruz kalan alüminyum alaşım materyaldeki korozyon oranı (0,187 mpy), K 0'a maruz kalan alüminyum alaşım materyaldeki korozyon oranından (0,022 mpy) çok daha yüksek bulunmuştur. Ve yine K 100'e maruz kalan paslanmaz çelik materyaldeki korozyon oranı (0,020 mpy), K 0'a maruz kalan paslanmaz çelik materyaldeki korozyon oranından (0,018 mpy) daha yüksek bulunmakla birlikte bu fark, pirinç ve alüminyum alaşıma oranla daha az kalmıştır. Birinell Sertlik ölçümleri; pirinç için K0, K10, K20 ve K100 için sırasıyla 100, 109, 100 ve 110 N/mm<sup>2</sup>, alüminyum alaşım için K0, K10, K20 ve K100 için sırasıyla 68, 73, 75 ve 81 N/mm<sup>2</sup>, paslanmaz çelik için K0, K10, K20 ve K100 için sırasıyla 156, 159, 164 ve 175 N/mm<sup>2</sup>, çekme dayanımları (TS) ise; pirinç için K0, K10, K20 ve K100 için sırasıyla 340, 370,6, 340 ve 374 MPa, alüminyum alaşım için K0, K10, K20 ve K100 için sırasıyla 231,2, 248,2, 255 ve 275,4 MPa, paslanmaz çelik için K0, K10, K20 ve K100 için sırasıyla 530,4, 540,6, 557,6 ve 595 MPa olarak belirlenmiştir. Tüm bu analizler ve aynı zamanda elektron mikroskopunda yapılan incelemeler neticesinde en büyük korozyonun pirinç materyalde, ardından alüminyum alaşım ve ardından da en az korozyonun paslanmaz çelik materyalde olduğu tespit edilmiştir. Deney öncesi ve sonrasında yapılan yoğunluk, su tayini, kükürt tayini, parlama noktası tespiti ve setan indisi hesapları da göz önüne alınarak K 10'un yakıt özelliği ve korozyon karakteristiği anlamında diğer oranlara nazaran dizel yakıtla daha yakın bir alternatif olduğu gözlemlenmiştir. Çalışmamız, çeşitli biyoyakıtların termo-fiziksel özelliklerinin

araştırılmasına öncü ve dizel-biyodizel karışımlarının endüstriyel uygulamalarında karşılaşılan korozyon sorunları ile ilgili çalışmalara bir rehber olabilir.

**Anahtar Sözcükler:** Dizel, Atık Lastik Piroliz Yağı, Mekanik Özellikler, Pirinç, Paslanmaz Çelik, Alüminyum Alaşım

### THE INVESTIGATION OF MECHANICAL AND CORROSIVE PROPERTIES OF PYROLYSIS OIL ON AUTOMOTIVE MATERIALS

#### ABSTRACT

Biodiesel fuels stand out with a number of advantages such as their high cetane number and low flash point temperatures. However, the corrosive effect of biodiesel or biodiesel fuel blends on engine materials continues to be one of the most studied disadvantages. When the studies in the literature are examined, it is noteworthy that there is a lack of studies that examine the corrosion processes of the materials used in the engine exposed to biodiesel, especially the surfaces in contact with the fuel, and the changes in the mechanical properties and fuel properties of these materials after exposure to biodiesel. Based on all these reasons, waste tire pyrolysis oil was obtained and mixed with diesel fuel at the ratios of 0%, 10%, 20% and 100% by volume to obtain blends named as K 0, K 10, K 20 and K 100. The K 0 blend is pure diesel fuel containing 0% waste tire pyrolysis oil, while the K 100 blend is pure waste tire pyrolysis oil containing 100% waste tire pyrolysis oil. All fuel blends obtained were analyzed according to ASTM standards. With static immersion method; brass, stainless steel and aluminium alloy from automobile materials; were exposed to pyrolyzed tire oil-diesel fuel mixtures obtained by mixing in different ratios and then its corrosion properties were determined. The mechanical properties of the materials were determined before and after this corrosion analysis, which was carried out according to ASTM standards. Morphological changes on the surfaces of the automobile materials subject to our study were also examined. In our study, remarkable results were obtained in brass, stainless steel and aluminum alloys that were exposed to our fuel mixtures prepared in different ratios for 1440 hours (60 days) by static immersion method. The corrosion rate of the brass material exposed to K 100 (0.102 mpy) was much higher than the corrosion rate of the brass material exposed to K 0 (0.042 mpy). The corrosion rate of aluminum alloy material exposed to K 100 (0.187 mpy) was much higher than the corrosion rate of aluminum alloy material exposed to K 0 (0.022 mpy). And again, the corrosion rate of stainless steel material exposed to K 100 (0.020 mpy) was higher than the corrosion rate of stainless steel material exposed to K 0 (0.018 mpy), but this difference was less than that of brass and aluminum alloy. Brinell Hardness measurements were 100, 109, 100 and 110 N/mm<sup>2</sup> for brass K0, K10, K20 and K100 respectively, 68, 73, 75 and 81 N/mm<sup>2</sup> for aluminum alloy K0, K10, K20 and K100 respectively, 156, 159, 164 and 175 N/mm<sup>2</sup> for stainless steel K0, K10, K20 and K100 respectively, and tensile strength (TS); 340, 370.6, 340 and 374 MPa for brass K0, K10, K20 and K100 respectively, 231.2, 248.2, 255 and 275.4 MPa for aluminum alloy K0, K10, K20 and K100 respectively, 530.4, 540.6, 557.6 and 595 MPa for stainless steel K0, K10, K20 and K100 respectively. As a result of all these analyzes and also the examinations made under the electron microscope, it was determined that the greatest corrosion was in the brass material, followed by the aluminum alloy and then the least corrosion in the stainless steel material. Considering the density, water determination, sulfur determination, flash point determination and cetane index calculations made before and after the experiment, it was observed that K10 is a closer alternative to diesel fuel in terms of fuel properties and corrosion characteristics compared to other ratios. Our study can be a pioneer in investigating the thermo-physical properties of various biofuels and a guide for studies on corrosion problems encountered in industrial applications of diesel-biodiesel blends.

**Keywords:** Diesel, Waste Tire Pyrolysis Oil, Mechanical Properties, Brass, Stainless Steel, Aluminum Alloy

#### Giriş

Dünyada gerçekleşen nüfus artışı, ekonomik büyüme ve teknolojik gelişmeler enerji ihtiyacını her geçen gün artırmakta olup söz konusu artış, ülkemizde de ihtiyaç duyulan enerji miktarının artması yanında bu ihtiyacı karşılamak üzere üretilen ve tüketilen enerji miktarlarını da aynı doğrultuda artırmaktadır. Yalnızca Türkiye’de

1990-2020 yılları arasında gerçekleşen enerji tüketimi sektörel bazda olmak üzere hemen tüm sektörlerde gözle görülür bir artış, neredeyse her yıl gerçekleşmiştir. (EİGM, 2023)

Aynı zamanda her geçen gün artan enerji tüketiminin direkt göstergelerinden birisi olan kişi başına enerji tüketimi de aynı şekilde dikkat çekmektedir. İnsanlar artık artan hayat konforu nedeni ile farklı tür enerjilere ihtiyaç duymaktadır. Buna paralel olarak da enerji tüketim miktarları ve çeşitliliği de her geçen gün artmaktadır.

Türkiye’de 1990 yılında enerji tüketiminin kişi başına düşen miktarı 0,94 TEP (Ton Eşdeğer Petrol) iken 2017 yılında bu değer 1,80 TEP olarak neredeyse iki katı olarak gerçekleşmiştir. (EİGM, 2023)

İnsanlık enerji ihtiyacını karşılamak amacıyla bugün dahi ağırlıklı olarak fosil kaynakları kullanmaktadır. Söz konusu bu kaynaklar ise gün geçtikçe azalmakta olup, yerlerini doldurabilecek alternatif enerji kaynaklarına yönelim artmaktadır. İnsanoğlu bir taraftan artan bu enerji ihtiyacını, diğer taraftan azal fosil kaynakları ikame edebilmek için her geçen gün farklı ve yenilenebilir enerji kaynaklarına önem vermekte ve uygulamaya almaktadır. 1980-2035 yılları arasındaki 55 yıllık projeksiyonda petrol tüketimi %16’lık bir azalış göstermektedir. Söz konusu bu azalışın zamanla diğer fosil kaynakların tümünde gerçekleşeceği ve enerji ikmali için zora gireceğimiz açıktır. (EİGM, 2023)

Gelişmiş ülkelerde enerji tüketiminin görece esaslı kısmını binalar oluşturmaktadır. Yine elektrik enerjisinin de çok büyük bir kısmı konutlarda kullanılmaktadır. Ekonomik gelişmelere paralel olarak enerjinin temel tüketim alanları yapılaşma ve ticari, sanayi, ulaşım ve konutlar şeklinde sayılmaktadır. Son yıllarda yapılaşmaya olan talep çok hızlı bir şekilde artmakta ve bu talebin karşılanabilmesi için gerçekleşen büyük ebat ve sayıdaki binalar enerji tüketimi üzerinde esaslı bir etki yaratmaktadır. Dolayısıyla büyük miktarlarda gerçekleşen bu enerji ihtiyacını karşılamak için özellikle alternatif enerji kaynaklarına olan talebin konutlarda da ön plana çıktığı görülmektedir. Bu bağlamda, fosil yakıtların hızlı bir şekilde tükenmesi, fiyatlarındaki artış ve yanmaları sonucu ortaya çıkan zararlı gazların oluşturduğu çevre kirliliği insanoğlunu farklı enerji kaynakları arayışına yönlendirmiştir. Günümüze değin birçok alternatif enerji kaynakları araştırmaları ve uygulamaları çalışılmıştır. Ancak bu alternatif yakıt çalışmaları pahalı olmaları, verimlerinin düşük olması ve depolama güçlükleri gibi bir takım zorluklar nedeni ile hiçbirinde petrolün muadili olabilecek bir sonuç elde edilememiştir.

Alternatif yakıt kaynaklarından birisi olarak piroliz yağı dikkat çekicidir. Çok değişik biyokütleler kullanılarak imal edilen piroliz yağları farklı yakıt sistemlerinde hem alternatif yakıt olarak hemde alternatif yakıt katkısı olarak kullanılagelmişlerdir. Piroliz işlemi, temel olarak oksijensiz ortamda organik maddelerin ısı yardımıyla bozulmasıdır. Bu tepkime sonucunda katı, sıvı ve gaz olmak üzere maddeler meydana gelmektedir. Bu işlemin en önemli özelliği atık statüsünde bulunan atık malzemelerin tekrar üretime kazandırılmasıdır.

Piroliz için kullanılan atık malzemelerden birisi de ömrünü tamamlamış lastiklerdir (ÖTL). Lastikler petrol ve mamullerinden üretilmiştir. Dünyada her yıl milyarlarca lastik atık olarak ortaya çıkmaktadır. Kullanılmamış bir otomobil lastiği yaklaşık olarak 11 kg, kullanılmış bir otomobil lastiği ise 9 kg’dır. Otobüsler ve kamyonlar gibi büyük vasıtaların ise lastik kütleleri kullanılmamış iseler 54 kg, kullanılmış iseler 45 kg’dır. Doğaya bırakılan bu büyüklükteki atıkların yönetilmesi çok zordur. Bu lastiklerin direkt olarak yakılması çevreye çok zararlı maddeler ortaya çıkardığından depolanmalarının dahî yasaklandığı ülkeler vardır. Ömrünü tamamlamış lastiklerin pirolizi sonucunda ortaya kömür, pirolitik yağ ve gaz çıkmaktadır. Pirolitik yağ doğrudan kazanlarda yakıt olarak kullanılabilmesinin yanı sıra dizel yakıtla karıştırılması gibi işlemlerden geçirildikten sonra içten yanmalı motorlarda da yakıt olarak kullanılabilmesine dair literatürde çalışmalar mevcuttur. Söz konusu pirolitik yağ-dizel karışımının otomobil sistemlerindeki etkileri üzerine yapılan araştırmalarda çeşitlenmektedir.

### **Kateryal ve Method**

Çalışmamız temel olarak; belli başlı otomobil materyallerinin, ömrünü tamamlamış atık lastiklerden elde edilen pirolitik yağın dizel yakıt katkısı maddesi olarak karıştırılması sonucunda elde edilen atık lastik pirolitik yağ-dizel yakıt karışımına statik olarak maruz bırakılmaları neticesinde, söz konusu bu otomobil materyallerinde meydana gelmesi muhtemel mekanik ve korozif etkilerinin araştırılmasını kapsamaktadır. Pirolitik yağ olarak, ülkemiz Adıyaman İlinde faaliyet gösteren Viollas Pirolitik Yağ Fabrikası tarafından, ömrünü tamamlamış atık lastiklerden piroliz yöntemi ile imal edilen atık lastik pirolitik yağ kullanılmıştır. Temin edilen söz konusu ömrünü tamamlamış atık lastiklerden elde edilen bu atık lastik pirolitik yağ, yine piyasadan temin edilen standart



özelliklere haiz bir dizel yakıt ile %0 (Saf Motorin), % 10, % 20 ve %100 (Saf Atık Lastik Pirolitik Yağ) oranlarında karıştırılarak çalışmamıza esas atık lastik pirolitik yağ-dizel yakıt karışımları elde edilmiştir.

Otomobil materyalleri oldukça çeşitlilik göstermekte olup bunların arasından çalışmamızda kullanılacak materyallerin belirlenmesinde ise; çalışmamıza esas olarak belirli oranlarda karıştırarak ortaya çıkardığımız atık lastik pirolitik yağ-dizel yakıt karışımının otomobilde, bilhassa motorda sürekli temasta bulunduğu yüzeyler tercih edilmiştir.

Şekil 4.1.'de görüldüğü üzere otomobil materyallerinin yakıt karışımı ile temas edeceği yüzeyler karmaşık bir bileşime sahip olması yanında temel olarak piston, silindir ve enjeksiyon pompasından oluşmaktadır. Motor içinde yakıt ile temas halinde bu üç temel yapının ise sırasıyla alüminyum alaşım, paslanmaz çelik ve pirinç gibi bakır alaşımlardan oluştuğu görülmektedir (Hoang, vd., 2020). Bu şekilde tespiti gerçekleştirilen materyallerin elde edilen yakıt karışımlarına statik daldırma yöntemi ile maruz bırakılmaları neticesinde ortaya çıkacak olan korozif ve mekanik değişiklikler ortaya konulacaktır.

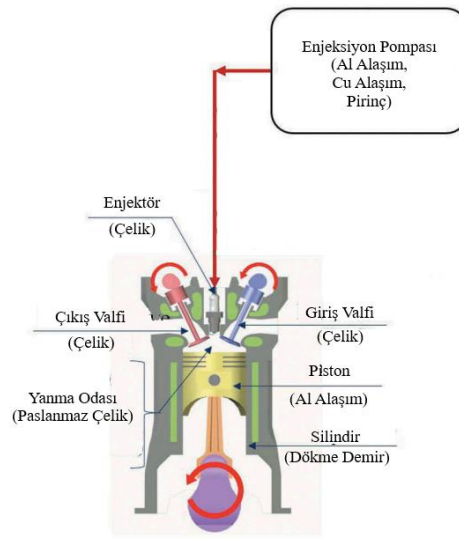

**Şekil 1.** Bir dizel motorun farklı mekanik parçalarının üretiminde kullanılan materyaller (Hoang, vd., 2020)

Çalışmamızda numune olarak kullanılmak üzere otomobil sektöründe paslanmaz çelik olarak özellikle kullanılagelmekte olan 316 Paslanmaz Çelik tercih edilmiştir. Pirinç alaşım ise gerek kullanım alanının genişliği, gerekse de kolay ulaşılabilirliği nedeni ile sanayide kullanılagelen ortak pirinç tercih edilmiştir. Alüminyum alaşım olarak ise; Şekil 4.2. ve Şekil 4.3.'de görüldüğü gibi orijinal bir otomobil pistonundan testimiz için gerekli boyut ve ölçülerde numuneler elde edilmiştir.

% 0, % 10, % 20 ve % 100 oranlarında hazırlanan atık lastik pirolitik yağ-dizel yakıt karışımları ve pirinç, paslanmaz çelik ve alüminyum alaşım olarak belirlenen otomotiv materyalleri yukarıda izah edildiği üzere bir kısım analizlerden geçirildikten sonra çalışmamızın uygulamalı kısmı olan statik daldırma işlemine geçilmiştir.

Şekil 4.17.'de görüldüğü üzere çalışmamıza temel olarak belirlenen oranlarda hazırlanan yakıt karışımlarına; yine tespiti yapıp hazırlanan otomotiv materyalleri statik daldırmaya maruz bırakılmışlardır.

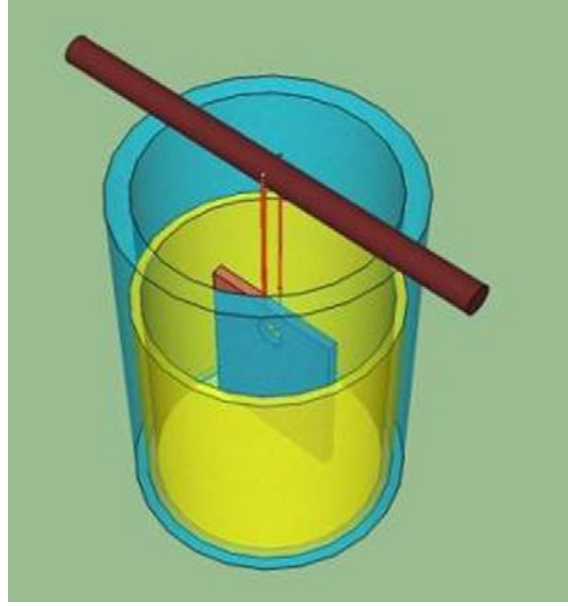

Şekil 2. Statik daldırma yönteminin şematik gösterimi (Aquino, vd 2012)

Çalışmamızın temelini oluşturan statik daldırma işlemi öncesinde yukarıda ayrıntılı bir şekilde açıklanmış olan analizler numunelerimiz üzerinde gerçekleştirilmiştir. Statik daldırma işlemi 50 gün, 1200 saat boyunca sürdürülmüştür. Çalışmamızda otomobil materyalleri üzerinde meydana gelen korozyon miktarı ve hızının tespiti için ASTM G1 standartlarına göre her 10 günde bir, yani her 240 saatte bir metal otomobil numuneleri üzerinde kütle ölçüm işlemleri gerçekleştirilmiştir. (Samuel & Gulum, 2019)

### Bulgular ve Tartışma

Çalışmamızın bu bölümünde öncelikle farklı oranlarda hazırlanan yakıt karışımlarına statik daldırma işlemi öncesinde ve sonrasında yapılan testlerde elde edilen veriler ayrıntılı olarak incelenecek ve irdelenecektir. Temel olarak iki ana başlık altında, otomobil materyalleri üzerinde yapılan analizler ve yakıt karışımları üzerinde yapılan analizler olmak üzere bulgular ve tartışma gerçekleştirilecektir.

Yakıt karışımları, içeriğindeki atık lastik pirolitik yağ oranına göre değişkenlik gösteren birtakım özelliklere sahip oldukları gözlemlenmiştir. Aşağıda Tablo 5.1.de gösterildiği üzere yakıt karışımlarının statik daldırma işlemi öncesindeki fiziksel özellikleri tespit edilmiştir. Tablo 5. 1. incelenecek olursa; herhangi bir işlem yapılmaksızın elde edilen karışımların yoğunluklarının, içeriklerindeki pirolitik yağ oranı ile doğru orantılı olarak arttığı görülmektedir.

Tablo 1. Statik Daldırma Öncesi Yakıt Karışımlarının Fiziksel Özellikleri

Özellikler	ASTM	K 0 (Motorin)	K 10	K 20	K100 (TLPY)
Yoğunluk (kg/m <sup>3</sup> , @15°C)	D1298	830,7	839,7	845,0	923,3
Kinematik Viskozite (mm <sup>2</sup> /s,	D445	2,9	3,2	3,9	4,5
Setan İndisi	D613	50,6	47,4	45,7	27,5
Parlama Noktası (°C)	D93	62,5	55,5	54,5	54,5
Su İçeriği % (m/m)	-	0,004	0,02	0,01	0,07
Kükürt (mg/Kg)	-	6,6	>500	>500	>500
CFPP (°C)	D6371	-18	-7	-7	-3

**Tablo 2.** İçerisine Pirinç Numune Daldırılan Yakıt Karışımlarının Daldırma Sonrası Fiziksel Özellikleri

Özellikler	ASTM	K 0 (Motorin)	K 10	K 20	K100 (TLPY)
Yoğunluk (kg/m <sup>3</sup> , @15°C)	D1298	830,7	839,9	845,3	925,2
Kinematik Viskozite (mm <sup>2</sup> /s, @40°C)	D445	3,5	3,7	4,2	5
Setan İndisi	D613	50,2	47,4	45,6	-
Parlama Noktası (°C)	D93	62,0	55,0	51,0	27,0
Su İçeriği % (m/m)	-	0,004	0,006	0,007	0,036
Kükürt (mg/Kg)	-	6,7	>500	>500	>500
CFPP (°C)	D6371	-20	-8	-7	-

**Tablo 3.** İçerisine Paslanmaz Çelik Numune Daldırılan Yakıt Karışımlarının Daldırma Sonrası Fiziksel Özellikleri

Özellikler	ASTM	K 0 (Motorin)	K 10	K 20	K100 (TLPY)
Yoğunluk (kg/m <sup>3</sup> , @15°C)	D1298	830,7	839,8	845,1	924,4
Kinematik Viskozite (mm <sup>2</sup> /s,	D445	2,9	3,3	3,9	4,6
Setan İndisi	D613	50,5	47,4	45,5	-
Parlama Noktası (°C)	D93	62,0	56,0	54,0	53,0
Su İçeriği % (m/m)	-	0,004	0,006	0,007	0,038
Kükürt (mg/Kg)	-	6,7	>500	>500	>500
CFPP (°C)	D6371	-20	-7	-7	-

**Tablo 4.** İçerisine Alüminyum Alaşım Numune Daldırılan Yakıt Karışımlarının Daldırma Sonrası Fiziksel Özellikleri

Özellikler	ASTM	K 0 (Motorin)	K 10	K 20	K100 (TLPY)
Yoğunluk (kg/m <sup>3</sup> , @15°C)	D1298	830,7	839,8	845,3	924,5
Kinematik Viskozite (mm <sup>2</sup> /s,	D4450	3	3,5	4	4,7
Setan İndisi	D613	50,9	47,1	45,4	-
Parlama Noktası (°C)	D93	62,0	55,0	53,0	29,0
Su İçeriği % (m/m)	-	0,004	0,005	0,007	0,042
Kükürt (mg/Kg)	-	6,7	>500	>500	>500
CFPP (°C)	D6371	-20	-8	-7	-

**Tablo 5.** Sırasıyla pirinç (1-4), paslanmaz çelik (5-8) ve alüminyum alaşım (9-12) materyallerinin kütle kayıpları

	1 (K0)	2 (K10)	3 (K20)	4 (K100)	5 (K0)	6 (K10)	7 (K20)	8 (K100)	9 (K0)	10 (K10)	11 (K20)	12 (K100)
0 saat	20,1615	20,13	20,346	20,1562	19,3488	19,437	19,3095	19,392	6,6704	6,1234	6,6705	6,256
240 saat	20,1624	20,1306	20,3483	20,156	19,35	19,4379	19,3095	19,391	6,6712	6,1242	6,6687	6,2538
480 saat	20,1595	20,1295	20,3478	20,1556	19,35	19,4354	19,3093	19,3898	6,671	6,1231	6,6695	6,2538
720 saat	20,1605	20,131	20,346	20,1548	19,349	19,4367	19,3086	19,3909	6,6707	6,123	6,6696	6,2536
960 saat	20,1592	20,1287	20,3455	20,1543	19,3484	19,4356	19,3085	19,3909	6,6702	6,1226	6,6696	6,2531
1200 saat	20,159	20,1287	20,3447	20,153	19,3481	19,4354	19,3085	19,3909	6,6702	6,1224	6,6694	6,2531
1440 saat	20,159	20,1283	20,3439	20,15	19,3478	19,4351	19,3085	19,3909	6,67	6,1222	6,6686	6,2526

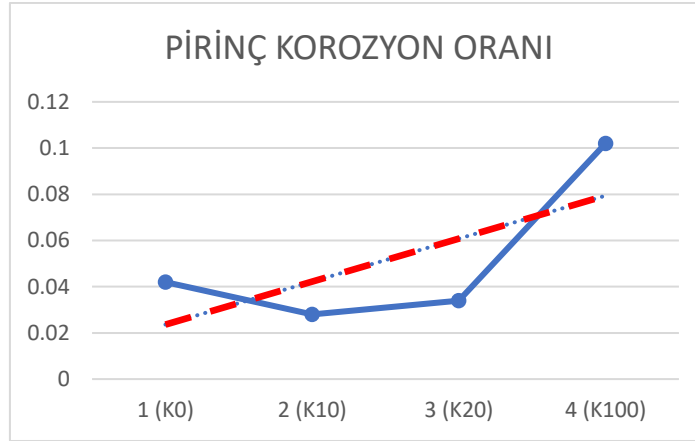
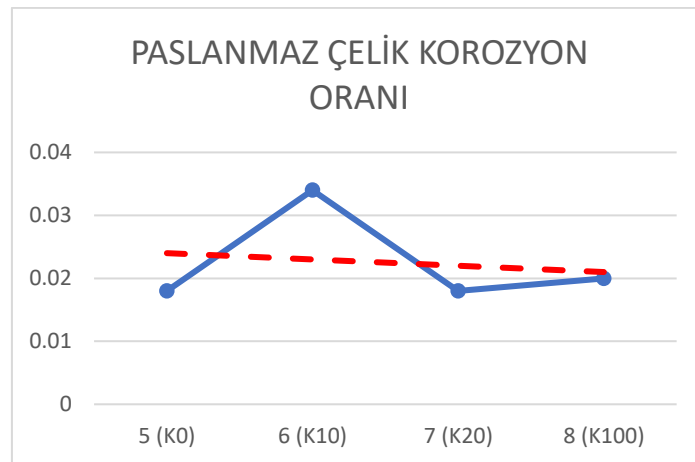
**Şekil 3.** Pirinç numune korozyon oranı**Şekil 4.** Paslanmaz çelik numune korozyon oranı

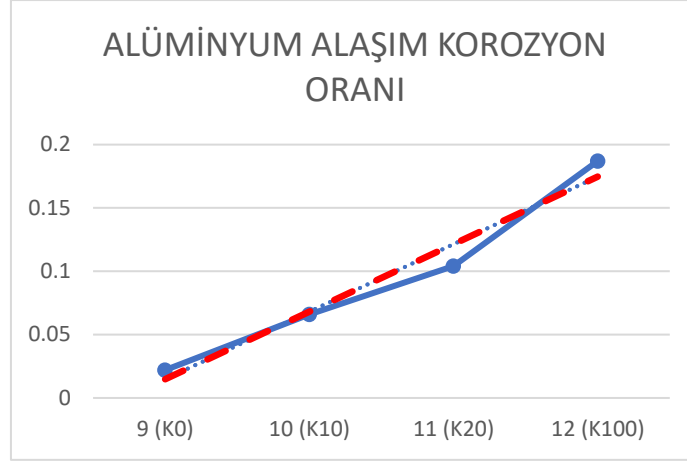

Şekil 5. Alüminyum alaşım korozyon oranı

Tablo 5 de materyallerdeki kütle değerleri verilmektedir. ASTM standartlarına göre yapılan analizlere göre elde edilen veriler ışığında Şekil 3, Şekil 4 ve Şekil 5 de gösterildiği üzere korozyon oranları gerçekleşmiştir.

Yine aşağıda sertlik ölçüm sonuçları verilmiştir.

Daldırma İşlemi Öncesi	
Alüminyum	74,15 HBW
Paslanmaz Çelik	155,82 HBW
Pirinç	100,72 HBW

Pirinç-Daldırma İşlemi Sonrası	
K0	103,1 HBW
K10	107,1 HBW
K20	107,4 HBW
K100	110,2 HBW

Alüminyum-Daldırma İşlemi Sonrası	
K0	70,4 HBW
K10	73,4 HBW
K20	75,5 HBW
K100	81,2 HBW

Paslanmaz Çelik-Daldırma İşlemi Sonrası	
K0	156,3 HBW
K10	159,1 HBW
K20	160,4 HBW
K100	175,2 HBW

Aşağıda ise SEM analiz görüntüleri verilmiştir. Korozyon bu görüntülerde açık bir şekilde görülmektedir.

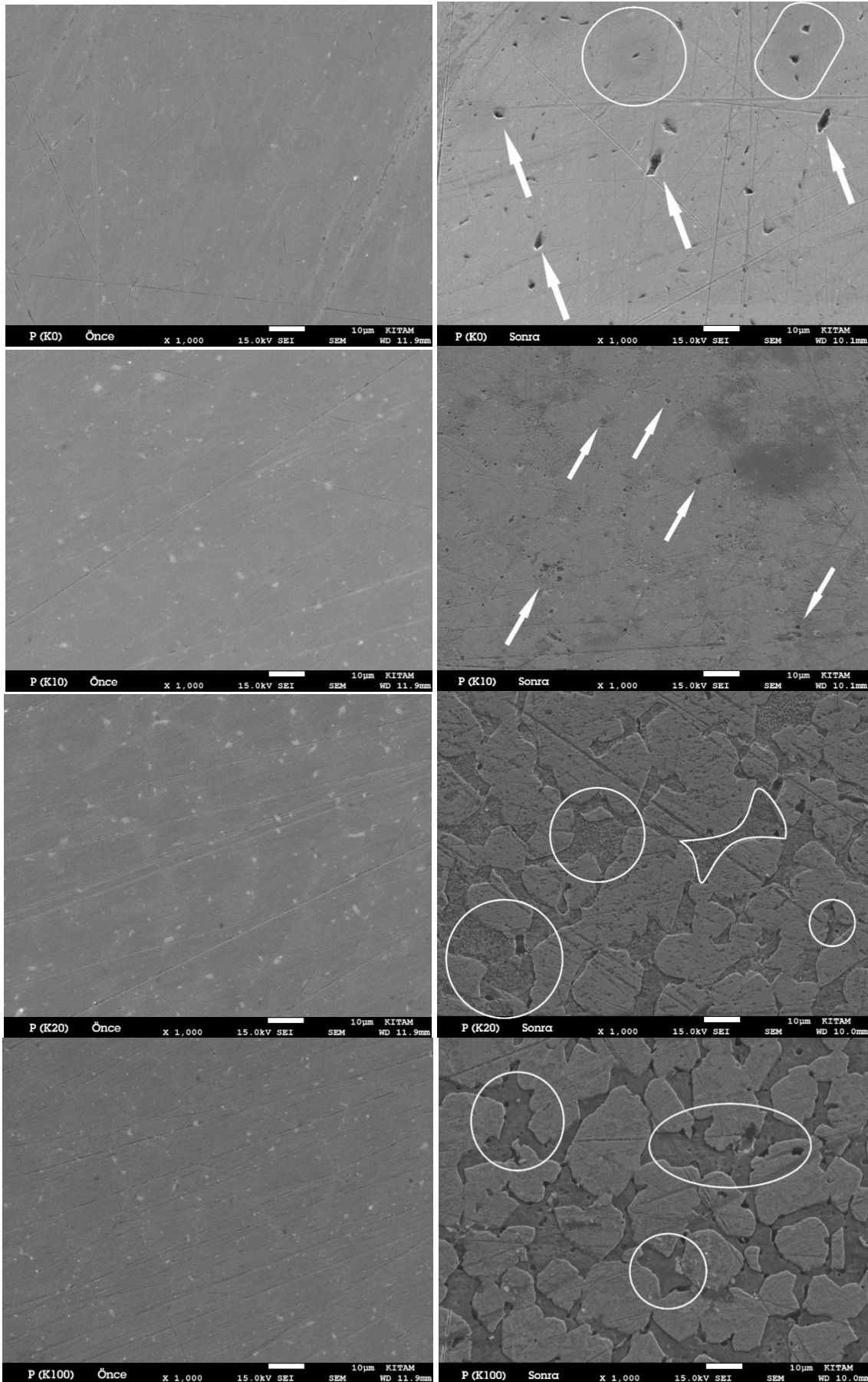

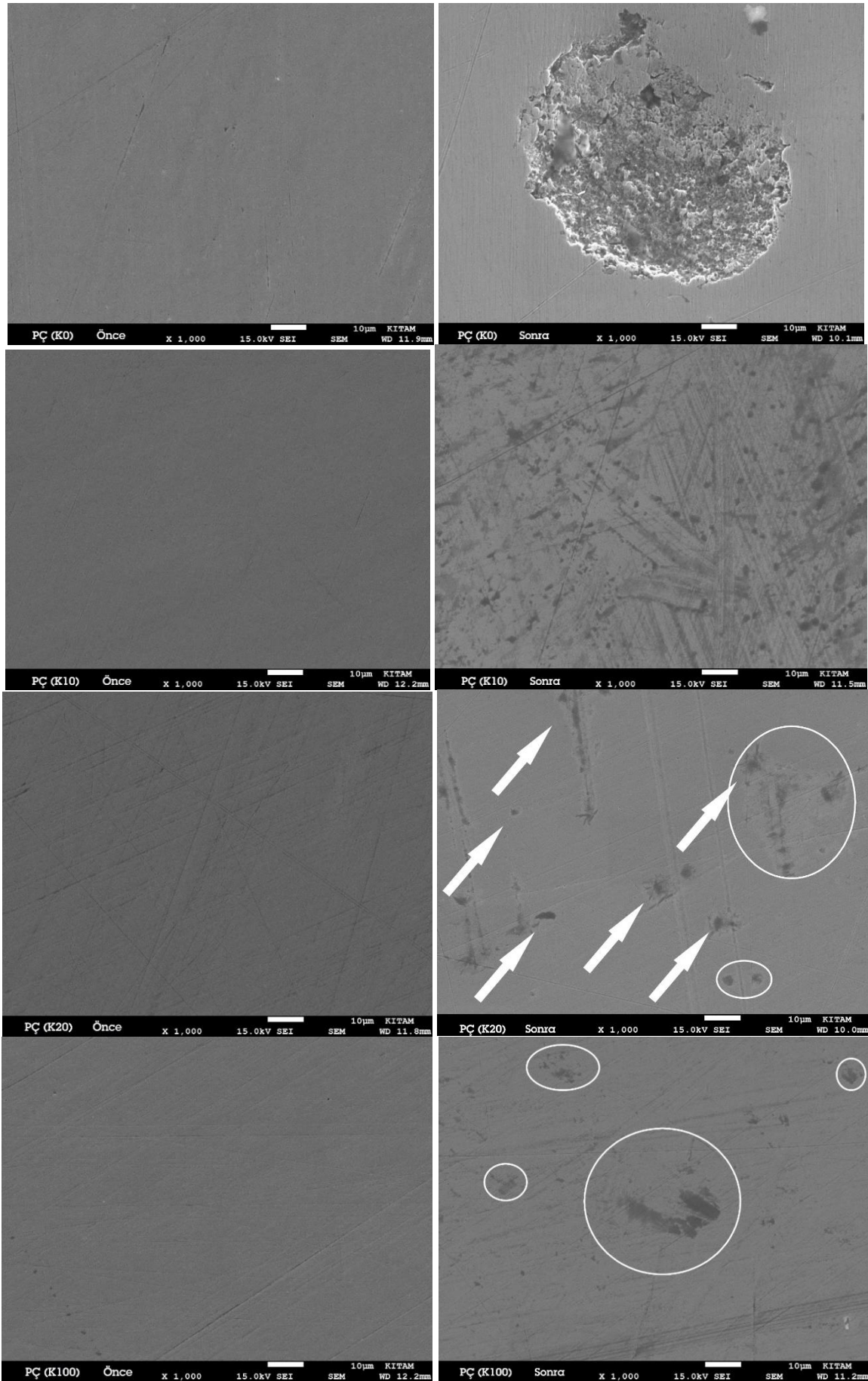

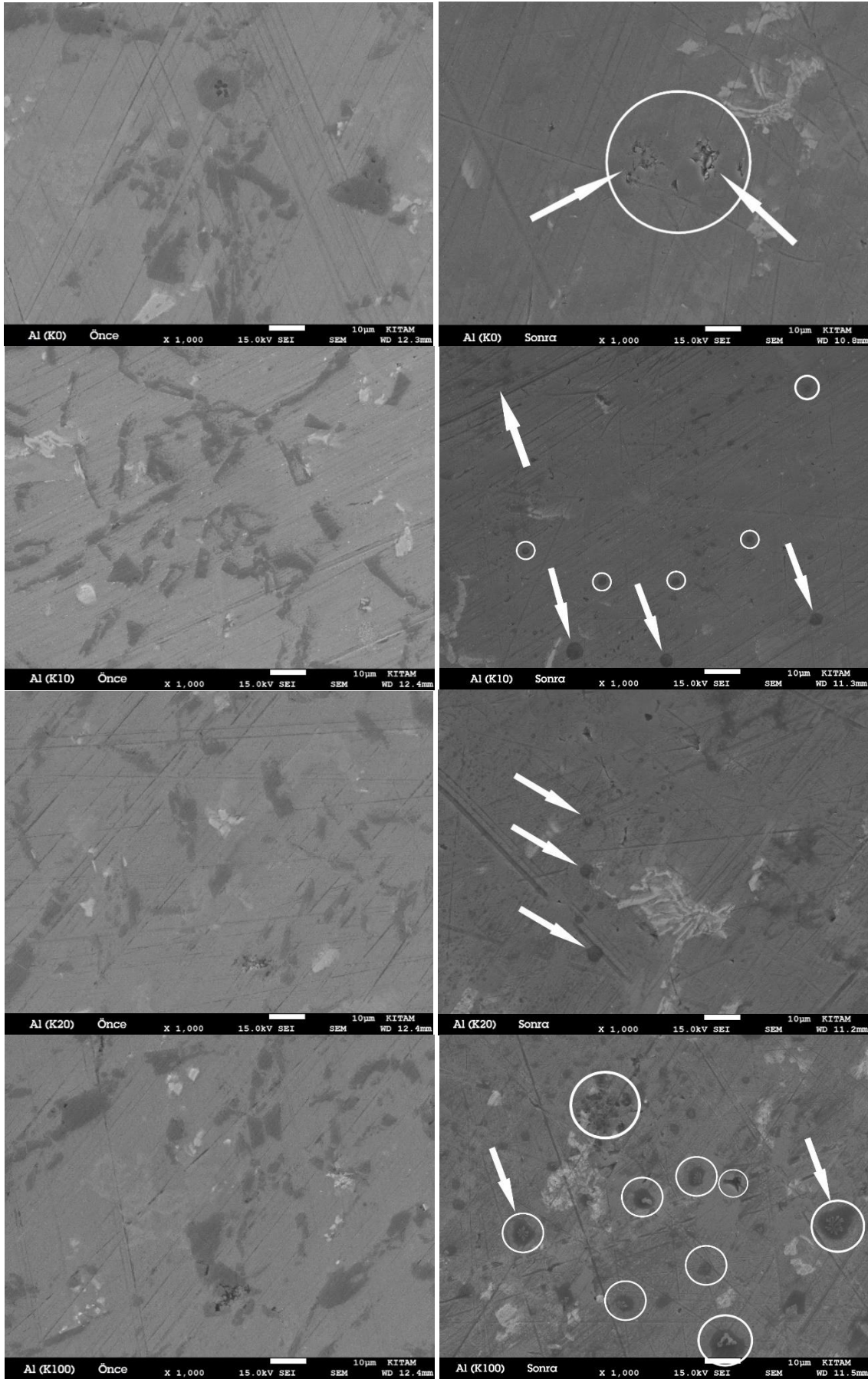

Şekil 6. SEM görüntüleri



### Sonuçlar ve Öneriler

Bu çalışmada sonuç olarak atık lastik piroliz yağının kullanımının artırılması amacıyla çeşitli otomotiv materyalleri üzerindeki etkileri incelenmiştir. ASTM standartlarına göre ölçüm işlemleri gerçekleştirilmiştir. Uluslararası daldırma standartlarına uygun olarak; farklı oranlarda hacimsel metod ile karıştırılarak elde edilen atık lastik pirolitik yağ-dizel yakıt karışımlarına maruz bırakılan materyallerde başta korozyon oranları belirlenmiştir. Daha sonra sertlik ölçümleri, SEM analizleri yapılmıştır. Tüm bunlar ışığında elde edilen veriler gelecek çalışmalara ışık olacaktır.

Çalışmamızdan aşağıdaki sonuçlar elde edilmiştir:

- Sülfür içeriği azalırken diğer önemli yakıt özellikleri yağ oranı ile birlikte artış göstermektedir.
- Tüm materyal türlerinde maruz kaldıkları yakıt karışımındaki yağ oranı arttıkça korozyon oranları da artmıştır.
- Dizel yakıtla oranla lastik pirolitik yağ-dizel karışımlarının neden olduğu korozyon oranları daha yüksek olmuştur.
- Otomotiv materyalleri arasında korozyon oranı en yüksek materyal pirinç, ardından alüminyum alaşım ve son olarak da paslanmaz çelik olarak gerçekleşmiştir.
- Lastik pirolitik yağ oranı arttıkça materyallerdeki sertlik oranı da artış göstermektedir. Aynı zamanda çekme mukavemeti ve nispeten koyu yüzey morfolojisi görünümleri de yağ oranları ile artış göstermektedir.
- Yakıt özellikleri anlamında tüm değişkenler birlikte değerlendirildiğinde K 10 karışımının dizele en yakın yakıt özelliklerine haiz olduğu gözlemlenmiştir.

### Kaynaklar

- Aquino, I. P., Hernandez, R. P. B., Chicoma, D. L., Pinto, H. P. F., & Aoki, I. V. (2012). Influence of light, temperature and metallic ions on biodiesel degradation and corrosiveness to copper and brass. *Fuel*, 102, 795-807.
- Chandran, D., Ng, H. K., Lau, H. L. N., Gan, S., & Choo, Y. M. (2016). Investigation of the effects of palm biodiesel dissolved oxygen and conductivity on metal corrosion and elastomer degradation under novel immersion method. *Applied Thermal Engineering*, 104, 294-308.
- Enerji ve Tabii Kaynaklar Bakanlığı, Enerji İşleri Genel Müdürlüğü, İstatistikler, Enerji İşleri Genel Müdürlüğü Raporları. Erişim: 29 Nisan 2023, <https://enerji.gov.tr/eigm-raporlari>.
- Haseeb, A. S. M. A., Masjuki, H. H., Ann, L. J., & Fazal, M. A. (2010). Corrosion characteristics of copper and leaded bronze in palm biodiesel. *Fuel Processing Technology*, 91(3), 329-334.
- Hoang, A. T., Tabatabaei, M., & Aghbashlo, M. (2020). A review of the effect of biodiesel on the corrosion behavior of metals/alloys in diesel engines. *Energy Sources, Part A: Recovery, Utilization, and Environmental Effects*, 42(23), 2923-2943.
- Kara, G. (2022). Kayısı Çekirdeği Kabuğundan Üretilen Pirolitik Yakıtın Bir Dizel Motorda Kullanımının Deneysel Olarak Araştırılması. Yüksek Lisans Tezi.
- Kugelmeier, C. L., Monteiro, M. R., da Silva, R., Kuri, S. E., Sordi, V. L., & Della Rovere, C. A. (2021). Corrosion behavior of carbon steel, stainless steel, aluminum and copper upon exposure to biodiesel blended with petrodiesel. *Energy*, 226, 120344.
- Samuel, O. D., & Gulum, M. (2019). Mechanical and corrosion properties of brass exposed to waste sunflower oil biodiesel-diesel fuel blends. *Chemical Engineering Communications*, 206(5), 682-694.
- Shahabuddin, M., Mofijur, M., Shuvho, M. B. A., Chowdhury, M. A. K., Kalam, M. A., Masjuki, H. H., & Chowdhury, M. A. (2021). A Study on the Corrosion Characteristics of Internal Combustion Engine Materials in Second-Generation Jatropa Curcas Biodiesel. *Energies*, 14(14), 4352.

Shehzad, A., Ahmed, A., Quazi, M. M., Jamshaid, M., Ashrafur Rahman, S. M., Hassan, M. H., & Javed, H. M. A. (2021). Current research and development status of corrosion behavior of automotive materials in biofuels. *Energies*, *14*(5), 1440.



### THE INTEGRAL ROLE OF ARCHITECTURAL DESIGNS IN ENERGY-EFFICIENT SMART CITIES

Seyda EMEKÇİ

Assoc.Prof Dr., Ankara Yıldırım Beyazıt University, Faculty of Architecture and Fine Arts, Department of Architecture, Ankara-Türkiye, (Responsible Author) ORCID: 0000-0002-5470-6485

#### ABSTRACT

Energy-efficient smart cities embody a forward-thinking paradigm for urban development in the 21st century. It has emerged as a possible solution for current global issues, including excessive resource consumption, as well as the scarcity of energy resources. Given that buildings account for approximately 30-40% of the worldwide energy consumption and residential buildings alone contribute to nearly 40% of the annual anthropogenic greenhouse gas emissions, it is crucial to initiate the process of creating smart cities at the architectural design stage. Architectural designs play a pivotal role in shaping sustainable and intelligent urban environments. By prioritizing architectural design, energy efficiency and being “smart” can be achieved.

The article highlights the importance of architectural design in reducing energy usage, decreasing carbon emissions, fostering energy-efficient smart cities.

**Keywords:** energy efficiency, smart cities, architectural design

#### Introduction

The phenomenon of climate change has resulted in a notable acceleration of annual mean temperatures on Earth, surpassing initial predictions (NASA, 2023). Humanity, when confronted with abrupt climate change, is exhibiting a suboptimal and ineffective response. Conversely, the global challenges of population growth, rapid urbanization, resource overconsumption, and scarcities in water and energy sources have emerged (IPCC, 2023).

It is widely observed that the global population residing in urban areas surpasses that residing in rural areas. In the year 2007, a significant milestone was reached as the global urban population surpassed the global rural population, marking a notable shift in the demographic landscape (Ritchie & Roser, 2018). Since then, the world population has predominantly resided in urban areas, signifying a sustained trend towards urbanization. The planet has experienced a notable phenomenon of accelerated urbanization within the last six decades. In the year 1950, the global population was predominantly residing in rural areas, with approximately 70 percent of individuals living in such settlements (United Nations, 2014). Conversely, urban settlements were inhabited by less than one-third, accounting for approximately 30 percent of the population. According to data from 2014, more than half of the global population, specifically 54 percent, resided in urban areas. It is projected that the urban population will experience further expansion, resulting in a global distribution by 2050 where approximately two-thirds (68 percent) will reside in urban areas, while one-third (32 percent) will reside in rural areas (United Nations, 2014). This anticipated shift represents a reversal of the rural-urban population distribution observed in the mid-twentieth century (United Nations, 2022). Based on the observed growth rates, it can be inferred that over the course of the next four decades, there is a projection of constructing a city with a population of one million residents on a weekly basis. The pattern of accelerated urban expansion from the mid-20th century to the present has resulted in a rise in economic and social prosperity in certain regions, while simultaneously perpetuating persistent poverty in others (UN, 2023). Urban areas are intricate systems that exhibit high levels of energy consumption. The excessive utilization of energy, water, materials, and both natural and man-made resources has a significant impact on the environment (IEA, 2021).

The emergence of the Smart City concept has arisen in response to a range of pressing global challenges that have unfolded over the past four decades (Obringer & Nateghi, 2021). These challenges include climate

change, rapid urbanization, and unsustainable resource consumption, among others (Emekci, 2022a). The concept encompasses a comprehensive range of interdisciplinary measures, ideas, and policies that are designed to promote the advancement of human and technological resources within urban areas. Its primary objective is to facilitate sustainable development and enhance the overall quality of life for the population residing in these areas (Emekci, 2022b).

In the global context of energy efficiency, it is crucial to emphasize that buildings account for 40% of the overall energy consumption in Europe and contribute to 36% of greenhouse gas emissions (EU Commission, 2020). This highlights the necessity of attaining energy-efficient structures in order to mitigate their CO<sub>2</sub> emissions and minimize their energy usage. Additionally, the built environment has a significant impact on the overall quality of life and productivity of individuals within a community. Therefore, it is imperative for buildings to possess the ability to not only incorporate measures that reduce their energy consumption, including the integration of self-sustaining energy sources, but also enhance the well-being and productivity of occupants. The architectural possibilities for energy-efficient smart cities are vast and diverse. Therefore, architectural designs have a significant impact on the development of sustainable and intelligent urban environments. Achieving energy efficiency and using smart technologies can be facilitated by placing emphasis on architectural design. The article emphasizes the significance of architectural design level in mitigating energy consumption, minimizing carbon emissions, and fostering being “smart”.

### **Exploring the Interplay between Architectural Design and Smart Cities**

The availability of energy is a crucial factor in determining the expansion of urban, national, and international areas. Additionally, this reliance poses obstacles to endeavors aimed at enhancing environmental quality and promoting sustainability. Due to escalated energy consumption within a growing economy, there will be a corresponding surge in CO<sub>2</sub> emissions, leading to a subsequent elevation in world temperatures. On the contrary, the process of urbanisation and the subsequent increase in population density have presented cities with greater difficulties in managing their energy consumption and mitigating their environmental footprint (Moubarak et al., 2018). Approximately 70% of worldwide carbon dioxide (CO<sub>2</sub>) emissions and two-thirds of global energy use can be linked to urban zones (EU Commission, 2020). Governments worldwide have made commitments to engage in cooperative efforts aimed at addressing global challenges pertaining to energy, climate, and the environment. Following the ratification of the initial international climate agreement in 2015, the European Union, the United States, and China made a commitment to reduce their greenhouse gas emissions in the subsequent decades. Smart city have the potential to mitigate CO<sub>2</sub> emissions and improve environmental conditions (Li, 2022).

Smart cities represent a novel concept aimed at effectively managing urban areas with the objective of enhancing sustainability and elevating the quality of life for residents (Oberascher et al., 2022). In addition, it is imperative for projects pertaining to digitalization and smart cities to contribute value in order to enhance both ecological and economic sustainability (Almihat et al., 2022). Nevertheless, this enhanced worth can be expressed in a more direct manner by initially deducting the advantages from the exertion (Trindade et al., 2017). Despite the fact that the concept of Smart City has been introduced and utilized in a systematic manner for several years, there remains a lack of consensus, although some degree of convergence can be observed in recent discourse. Caragliu et al. (2011) defined smart city as “... *when investments in human and social capital and traditional (transport) and modern (ICT) communication infrastructure fuel sustainable economic growth and a high quality of life, with a wise management of natural resources, through participatory governance.*” Cocchia (2014) added valuable contributions to the definition. According to him, it can be inferred that innovation and technology are significantly contributing to the enhancement of quality of life. Furthermore, the essence of the definition is contingent upon the academic or societal context, encompassing areas such as research, economy, administration, and politics. Nam and Pardo (2011) provide a comprehensive analysis of the concept, highlighting three key dimensions. Firstly, the dimension of 'technology' emphasizes the role of mediated services in enhancing the efficiency of infrastructure utilization. Secondly, the dimension of 'people' underscores the importance of well-educated individuals in bolstering human infrastructure and facilitating collective decision-making processes. Lastly, the dimension of 'institutions' emphasizes the proactive involvement of institutions, in conjunction with citizen engagement, in promoting effective smart city development (Nam & Pardo, 2011). Therefore, the concept of the 'Smart City' should be considered as the

amalgamation of all pertinent dimensions (Giffinger, 2015). In addition to all this, In order to attain the objective of establishing a sustainable global environment, it is imperative for smart cities to effectively tackle the challenge of constructing their infrastructure by incorporating state-of-the-art technologies that optimize energy consumption and minimize adverse environmental consequences (Almihat et al., 2022).

The level of intelligence exhibited by an entity is derived from the collective intelligence of its individual components. In the context of smart cities, it is imperative that the constituent buildings possess “smart” capabilities. The establishment of “smart” and “sustainable” building is of utmost importance in addressing the challenges posed by climate change and many environmental concerns. Throughout history, the development of buildings has progressed from fundamental constructions to intricate structures that serve as both shelters and spaces for the production of goods and services. The emergence of smart houses and smart buildings has become a prominent area of research in the past decade from an academic perspective (i.e. Alam et al., 2012; Aldrich, 2003; Ghosh, 2018; Radha, 2022). The concept of smart managed housing is closely linked to the ideas of enhanced comfort, economic advantages, and, in contemporary times, decreased energy usage (Kastner et al., 2005).

The energy crisis and limitations experienced throughout the 1970s brought attention to the significant energy consumption associated with creating comfortable indoor environments in buildings. Consequently, this renewed focus on climatic design and energy efficiency as crucial considerations. Architects and designers have historically been required to incorporate considerations for the natural environment and local climatic conditions into their designs. Additionally, this strategy has the potential to reduce environmental pollutants and minimize energy use (Emekci, 2023). Subsequently, architectural design strategies had a resurgence in favor (Du et al., 2020). Although technology is frequently associated with these strategies, there have been instances where simple strategies have successfully accomplished this objective (i.e vernacular architecture). This task necessitates the reintegration of architectural design at the forefront of discussions, ensuring its alignment with smart technologies, and striving to enhance their influence.

### **Housing as “smart”**

The “home” serves as the foundational entity whereby its inhabitants engage in the consumption of water and energy, the generation of waste, and the pursuit of a safe and healthy environment, mobility, security, and sustainable living (Ghosh, 2018). Therefore, prioritizing residential areas is a fundamental necessity for the achievement of a prosperous Smart city. A home can be considered intelligent or “smart” when it actively and efficiently contributes to the broader society. In the contemporary era of digital connectivity, smart homes are frequently associated with internet-enabled, sensor-driven intelligent electro-physical appliances and applications that regulate several facets of residential environments. In order to truly embody the concept of being “Smart,” smart homes must possess the capability to support the various elements associated with smart cities. The table 1 presented below provides a visual representation of the architectural inputs required for smart homes that support the facilities and services of a smart city.

*Table 1 Architectural Considerations for the Implementation of Smart Homes.*

Components of Smart City (Features)	Architectural Contributions (Examples, not limited to)
Adequate water supply	Rainwater harvesting
Assured electric supply	Green building
Sanitation & Solid Waste	Zoning planning for redevelopment and greenfield development
Mobility	Space Planning
Affordable housing	Design re-engineering, Eco-friendly and low cost local materials
IT connectivity	Zoning for better line of sight
Sustainable environment	Green Zone, Green Buildings
Safety	CCTV grids
Health	Zoning, easy access to buildings, cycling and walking zones, parking

**Source:**(Ministry of Urban Development, 2015)

Based on the information presented in the Table1, it is apparent that the integration of architectural planning and technology can provide more ecologically favorable outcomes in relation to the ultimate product, despite the prevailing belief that technology alone can accomplish many of these objectives. There has been a notable increase in the utilization and implementation of passive design strategies, along with its associated concepts and principles (Fadli, 2019). Many countries, regions, and governments have been motivated to develop their own methods for labeling and evaluating building (i.e.Larsson, 1999; Zhu et al., 2013) . The predominant emphasis of these standards and models lies in performance-oriented aspects, rather than prioritizing the technology. According to Amato and Skelhorn (2014), a building constructed with passive strategies aims to achieve a minimum of a 50% decrease in cooling load annually, while also reducing electrical energy and water consumption. The building also seeks to decrease investment expenses by one-fifth. Furthermore, there is a notable emphasis on the interplay between users and spaces, as well as the exploration of innovative approaches to sustainability through the development of integrated smart systems.

### **Integrating Intelligence into Architectural Design**

The development of a building project is guided by overarching criteria that govern its progression in subsequent stages. Typically, these criteria encompass functional, economic, social, and temporal considerations. In order to achieve sustainability and being “smart, a comprehensive design process that beyond the standard method is required. Ensuring the high quality of design entails adopting an approach that prioritizes building performance. This involves assembling an integrated and interdisciplinary project team that collaboratively engages in integrated planning and meticulous project preparation to optimize performance outcomes. Therefore, the design process holds significant importance as it is during this stage that the majority of decisions impacting the performance of a building during its usage are made. Some criteria for this are listed below.

- The design of space layout holds significant importance in architectural design, occurring at the initial stages of "scheme design" and "design development" in the early part of the design process. The design variables associated with space layouts encompass function allocation, space dimension, space form, interior partition, and interior opening (Musau & Steemers, 2008; Yi, 2016). If space layouts are planned within a flexible border, the dimensions, form, and orientation of the boundary can be altered accordingly (Zawidzki et al., 2011). Table 2 shows design variable of space layouts.

Table 2 Design variables

Design Variables of Space Layouts (with a Non-Fixed Boundary)		Space Properties		Envelope Design
Space layout design (within a fixed boundary)	<ul style="list-style-type: none"> <li>Boundary dimension</li> <li>Boundary form</li> <li>Orientation</li> </ul>	Functional requirements	Use of spaces	<ul style="list-style-type: none"> <li>Thermal transmittance</li> <li>Window area</li> <li>Window location</li> <li>Glazing type</li> <li>Shading type and effectiveness</li> <li>Air tightness</li> </ul>
<ul style="list-style-type: none"> <li>Function allocation</li> <li>Space dimension</li> <li>Space form</li> <li>Interior partition</li> <li>Interior opening</li> </ul>		<ul style="list-style-type: none"> <li>Set-point temperature for heating</li> <li>Set-point temperature for cooling</li> <li>Lighting requirements (e.g., illuminance)</li> <li>Ventilation requirement (e.g., air flow rate)</li> <li>Control types</li> </ul>	<ul style="list-style-type: none"> <li>Occupancy, activity and schedule</li> <li>Internal gains from appliances and lighting</li> <li>Opening state of windows and doors</li> </ul>	

Source: (Du et al., 2020)

The variables that were taken into account in assessing sustainability throughout the conceptual design phase were those relating to energy consumption and being “smart”, as these factors were deemed to have a significant influence on sustainability.

- Smart architectural design is distinguished by its ability to provide an impartial assessment of the functionalities of building facilities. Architecture has evolved into a platform for the collection, processing, and examination of information. The intelligent design architecture is capable of monitoring and detecting flaws or vulnerabilities in the construction of buildings, so ensuring the safety and comfort of the residents. Reducing the total operating cost is advantageous due to the provision of dependable, real-time monitoring or onsite tracking (Rashdan & Mhatre, 2019). Smart architectural design can be defined as the outcome of employing strategies aimed at enhancing the adaptability of the structural compartments, with the objective of reducing the number of designed compartments while however conforming to all necessary specifications.
- Spatial flexibility ensures the ability to make adjustments to spatial configurations and compositions in accordance with the specific requirements and capabilities of inhabitants. The design philosophy promotes the adaptability and flexible configurations of architectural structures, empowering people to exert greater influence over spatial arrangements. Space is defined by its physical dimensions, its flexibility, and its utilization. Houses primarily offer essential provisions such as protection from the elements, an area for dining, a venue for socializing with others and communicating with loved ones, a space for mobility, dressing, and unwinding. The fundamental components of effective design result in significant alterations in physical environments, regardless of personal style preferences. Each space has the potential to be designed with confidence and individuality. The initial step in creating a smart and aesthetically pleasing room that reflects your personality and accommodates your family is to begin with space planning. This involves determining the layout and organization of the room before proceeding with the addition of furniture and decorative elements (Yi, 2016).
- Smart interior design refers to a comprehensive approach that integrates various innovative and technological solutions, such as digital materials, decorations, electronics, and sensors. The term "interior design" originates from the practice of implementing decorative elements and arranging the interior space. In order to improve living conditions, it is important to manage various functions such as ventilation, lighting, temperature control, alarms, occupancy control, and social contact in an IP environment using a mobile app on a PC. This allows for prompt response to residents' requests and the ability to make efficient decisions that will create a clear, pleasant, productive, and healthy living environment (Brown et al., 2017). Intelligent interior design offers effective and adaptable solutions to meet the diverse and complex needs of occupants. It aims to identify the most efficient strategies for creating a pleasant, comfortable, and enjoyable environment while also considering cost-effectiveness. Furthermore, the incorporation of construction structures that employ interior design technology can enhance the occupants' experience by addressing their needs and preferences. This can result in more intricate operations, improved comfort levels, enhanced energy efficiency, and reduced costs, ultimately leading to a more efficient interior design (Radha, 2022).

## Conclusion

The occurrence of climate change has led to a significant increase in average annual temperatures on our planet, exceeding the initial projections as reported by NASA in 2023. The global community's response to sudden climate change has been deemed suboptimal and ineffective. On the other hand, it is worth noting that there are significant global challenges that have arisen, namely population growth, rapid urbanization, resource overconsumption, and scarcities in water and energy sources (IPCC, 2023). The development of the Smart City concept has been prompted by a multitude of significant global challenges that have unfolded during the course of the last four decades. Some of the challenges that society currently faces encompass climate change, the rapid process of urbanization, and the issue of unsustainable resource consumption, among various others.

The built environment plays a crucial role in influencing the overall quality of life and energy efficiency. Hence, it is crucial for buildings to possess the capacity to not only integrate strategies that mitigate their energy consumption, such as the incorporation of self-sustaining energy sources, but also enhance the overall well-being and productivity of their occupants. The architectural potential for the development of energy-efficient smart cities is extensive and characterized by a wide range of possibilities. Hence, it can be argued that architectural designs play a pivotal role in shaping the progress of sustainable and intelligent urban environments.

There is a significant focus on the interaction between architectural design and spaces, as well as the investigation of novel strategies for sustainability through the creation of integrated smart systems. Re-evaluation of architectural design variables with "smart" technologies, reconsidering the adaptability and flexible configurations of architectural structures, driving "Smart Architectural Design", and "Smart Interior Design" keywords to the future academic studies, "Smartization" can be done starting from the architectural design level.

## References

- Alam, M. R., Reaz, M. B. I., & Ali, M. A. M. (2012). A Review of Smart Homes—Past, Present, and Future. *IEEE Transactions on Systems, Man, and Cybernetics, Part C (Applications and Reviews)*, 42(6), Article 6. <https://doi.org/10.1109/TSMCC.2012.2189204>
- Aldrich, F. K. (2003). Smart Homes: Past, Present and Future. In R. Harper (Ed.), *Inside the Smart Home* (pp. 17–39). Springer London. [https://doi.org/10.1007/1-85233-854-7\\_2](https://doi.org/10.1007/1-85233-854-7_2)
- Almihat, M. G. M., Kahn, M. T. E., Aboalez, K., & Almaktoof, A. M. (2022). Energy and Sustainable Development in Smart Cities: An Overview. *Smart Cities*, 5(4), 1389–1408. <https://doi.org/10.3390/smartcities5040071>
- Amato, A., Skelhorn, C., & Council, Q. G. B. (2014). *Qatar Case Study Passivhaus Project: The Baytna Scientific Partnership*. Qatar Green Building Council, Doha, Qatar.
- Brown, J. N. A., Fercher, A. J., & Leitner, G. (2017). Building an Intuitive Multimodal Interface for a Smart Home—Hunting the SNARK. *Human-Computer Interaction Series*. <https://api.semanticscholar.org/CorpusID:37452363>
- Caragliu, A., Del Bo, C., & Nijkamp, P. (2011). Smart Cities in Europe. *Journal of Urban Technology*, 18(2), Article 2. <https://doi.org/10.1080/10630732.2011.601117>
- Cocchia, A. (2014). *Smart and Digital City: A Systematic Literature Review* (pp. 13–43). [https://doi.org/10.1007/978-3-319-06160-3\\_2](https://doi.org/10.1007/978-3-319-06160-3_2)
- Du, T., Jansen, S., Turrin, M., & van den Dobbelsteen, A. (2020). Effects of Architectural Space Layouts on Energy Performance: A Review. *Sustainability*, 12(5). <https://doi.org/10.3390/su12051829>



- Emekci, S. (2022a). From Smart Homes to Smart Cities: How Smart Homes Contribute to the Sustainable Development Goals. In *Smart Cities, Citizen Welfare, and the Implementation of Sustainable Development Goals* (pp. 321–337). IGI Global. <https://doi.org/10.4018/978-1-7998-7785-1.ch018>
- Emekci, S. (2022b). *Sustainable City: Is It Enough To Ensure Sustainable Future?* 159–167.
- Emekci, S. (2023). *Return to the Basics: Vernacular Architecture as a Tool to Address Climate Change* (pp. 215–228). <https://doi.org/10.4018/978-1-6684-4829-8.ch011>
- EU Commission. (2020). *In focus: Energy efficiency in buildings*. In Focus: Energy Efficiency in Buildings. [https://commission.europa.eu/news/focus-energy-efficiency-buildings-2020-02-17\\_en](https://commission.europa.eu/news/focus-energy-efficiency-buildings-2020-02-17_en)
- Fadli, F. (2019). Medinas: From Vernacular to Smart Sustainable Cities and Buildings. *Proceedings of the International Conference on GSM4Q: Game Set and Match IV 2019 Qatar Connecting People Spaces Machines*, 175–178. <https://doi.org/10.29117/gsm4q.2019.0023>
- Ghosh, S. (2018). *Smart homes: Architectural and engineering design imperatives for smart city building codes* (p. 4). <https://doi.org/10.1109/ICSESP.2018.8376676>
- Giffinger, R. (2015). Smart City Concepts: Chances and Risks of Energy Efficient Urban Development. In M. Helfert, K.-H. Krempels, C. Klein, B. Donellan, & O. Guiskhin (Eds.), *Smart Cities, Green Technologies, and Intelligent Transport Systems* (pp. 3–16). Springer International Publishing.
- IEA. (2021). *Empowering Cities for a Net Zero Future – Analysis*. IEA. <https://www.iea.org/reports/empowering-cities-for-a-net-zero-future>
- IPCC. (2023). *AR6 Synthesis Report: Climate Change 2023 — IPCC*. AR6 Synthesis Report: Climate Change 2023. <https://www.ipcc.ch/report/sixth-assessment-report-cycle/>
- Kastner, W., G. Neugschwandtner, S. Soucek, & H. M. Newman. (2005). Communication systems for building automation and control. *Proceedings of the IEEE*, 93(6), 1178–1203. <https://doi.org/10.1109/JPROC.2005.849726>
- Larsson, N. K. (1999). Development of a building performance rating and labelling system in Canada. *Building Research & Information*, 27(4–5), 332–341. <https://doi.org/10.1080/096132199369444>
- Li, B. (2022). Effective energy utilization through economic development for sustainable management in smart cities. *Energy Reports*, 8, 4975–4987. <https://doi.org/10.1016/j.egy.2022.02.303>
- Ministry of Urban Development. (2015). *Smart Cities—Mission Statement & Guidelines*. Government of India.
- Moubarak, L., Bakeer, L., & Rashed, A. (2018). *SMART URBAN DESIGN IN EGYPT: POTENTIALS AND CHALLENGES*.
- Musau, F., & Steemers, K. (2008). Space Planning and Energy Efficiency in Office Buildings: The Role of Spatial and Temporal Diversity. *Architectural Science Review*, 51(2), 133–145. <https://doi.org/10.3763/asre.2008.5117>
- Nam, T., & Pardo, T. (2011). Conceptualizing smart city with dimensions of technology, people, and institutions. In *ACM International Conference Proceeding Series* (p. 291). <https://doi.org/10.1145/2037556.2037602>
- NASA. (2023). *Evidence | Facts – Climate Change: Vital Signs of the Planet*. How Do We Know Climate Change Is Real? <https://climate.nasa.gov/evidence/>
- Oberascher, M., Rauch, W., & Sitzenfrei, R. (2022). Towards a smart water city: A comprehensive review of applications, data requirements, and communication technologies for integrated management. *Sustainable Cities and Society*, 76, 103442. <https://doi.org/10.1016/j.scs.2021.103442>

- Obringer, R., & Nateghi, R. (2021). What makes a city 'smart' in the Anthropocene? A critical review of smart cities under climate change. *Sustainable Cities and Society*, 75, 103278. <https://doi.org/10.1016/j.scs.2021.103278>
- Radha, R. K. (2022). Flexible smart home design: Case study to design future smart home prototypes. *Ain Shams Engineering Journal*, 13(1), 101513. <https://doi.org/10.1016/j.asej.2021.05.027>
- Rashdan, W., & Mhatre, V. (2019). IMPACT OF HERITAGE ON CONTEMPORARY SUSTAINABLE INTERIOR DESIGN SOLUTIONS. *The Sustainable City XIII*. <https://api.semanticscholar.org/CorpusID:213966393>
- Ritchie, H., & Roser, M. (2018). Urbanization. *Our World in Data*. <https://ourworldindata.org/urbanization>
- Trindade, E. P., Hinnig, M. P. F., da Costa, E. M., Marques, J. S., Bastos, R. C., & Yigitcanlar, T. (2017). Sustainable development of smart cities: A systematic review of the literature. *Journal of Open Innovation: Technology, Market, and Complexity*, 3(3), 1–14. <https://doi.org/10.1186/s40852-017-0063-2>
- UN. (2023). *Department of Economic and Social Affairs*. <https://www.un.org/development/desa/en/news/population/2018-revision-of-world-urbanization-prospects.html>
- United Nations. (2014). *World Urbanization Prospects*. United Nations.
- United Nations. (2022). *World Population Prospects 2022*. Department of Economic and Social Affairs Population Division. <https://population.un.org/wpp/>
- Yi, H. (2016). User-driven automation for optimal thermal-zone layout during space programming phases. *Architectural Science Review*, 59(4), 279–306. <https://doi.org/10.1080/00038628.2015.1021747>
- Zawidzki, M., Tateyama, K., & Nishikawa, I. (2011). The constraints satisfaction problem approach in the design of an architectural functional layout. *Engineering Optimization*, 43(9), 943–966. <https://doi.org/10.1080/0305215X.2010.527005>
- Zhu, Y., Song, L., & Damiens, J. (2013). State of the art of green building standards and labelling system development in China. *International Journal of Sustainable Building Technology and Urban Development*, 4(3), 178–184. <https://doi.org/10.1080/2093761X.2013.837216>



## MODIFIED TRI-STATE STEP-UP CONVERTER WITH COUPLED COILS

Felix A. HIMMELSTOSS

Faculty of Electronic Engineering and Entrepreneurship, University of Applied Sciences Technikum Wien, Vienna, AUSTRIA  
ORCID: 0000-0001-8482-2295

### ABSTRACT

Starting from an already published tri-state step-up converter, a modified one is presented and treated which overcomes the disadvantages of the original circuit. This new converter has no inrush-current, the original converter, however, has, when connected to a stable DC supply (e.g. car batteries or a DC micro-grid buffered by batteries or large capacitors), a large inrush current. The converter consists of two coupled windings, two active switches, two diodes and a capacitor. In the stationary case the converter has three modes. During mode M1 both active switches are turned on and energy is taken from the input voltage source. When the first switch is turned off, the first diode turns on and the converter is in the idling mode (mode M2) and the flux in the coils are constant. When the second switch is turned off too, the first diode turns off too and the second diode turns on (mode M3). Now both windings are in series, and because the flux in the magnetic device must be steady, the current through the first winding is reduced and the current through the second winding must be equal to the one in the first winding. The differences between the original and the modified topologies are explained, the steady-state is described and the large and the small signal models of the converter are derived. The transfer functions are calculated and shown for an operating point. The start-up is analyzed. The investigations are proved by LTSpice simulations. Other possible topological changes are also shown which improve the efficiency of the converter.

**Keywords:** DC/DC converter, step-up converter, modelling, simulation, coupled coils

### I. INTRODUCTION

A new tri-state Boost converter with coupled coils is presented in [1] and depicted in Fig. 1 and is the starting point for this investigation. It is a modification of the well-known Boost converter, which is described in all the textbooks on Power Electronics (e.g. [2-4]). Another concept to change the voltage transformation ratio of a DC/DC converter which leads also to tri-state converters is described and applied to several converters in [5]. It should be mentioned that the voltage transformation ratio differs from the one treated here.

Making a literature review about tri-state converters one finds several topologies. The bidirectional noninverting Buck-Boost converter can be used [6, 7, 8,]. When both low side switches are on, the converter coil is short circuited and the third state occurs. [9] shows a topology with five switches and a pair of couple coils which can work as a step-up-down converter.

The topology used in [1] without coupled coils can be found in [10, 11, 12]. A controller design is shown in [13]. A tri-state Boost converter (but also without coupled coils) with a topology with little reduced forward-losses is treated in [14, 15] and an extension with zero-voltage switching (ZVS) can be found in [16]. Another ZVS concept is treated in [17]. In [18] the position of the zero is discussed and in [19] a controller design is treated. An interesting topology for an inverting tri-state Buck-Boost converter is shown in [20]. The concept [1] is a new converter topology, and in this paper another improvements and modifications are done.

#### A. Original converter

The circuit consists of two electronic switches S1 and S2, two diodes D1 and D2, two magnetically coupled windings N1 and N2 and a capacitor. The input voltage U1 is applied to the converter on the left side, and on the right side the output voltage U2 is connected to the load, here represented by the resistor R1. The converter has three modes which follow one after another during a switching period. During mode M1 both active switches

S1 and S2 are turned on and the current through N1 increases. Mode M2 starts when S1 is turned off. Now the current through N1 commutates into the diode D1 and free-wheels. When S2 is also turned off, the current commutates into the second winding N2 and therefore D2 turns on and feeds energy to the output. When the switching period is over, S1 and S2 are turned on again.

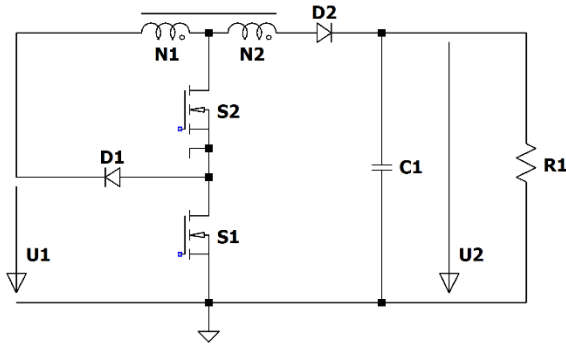

Fig. 1. Original tri-state converter with coupled coils according to [1].

When the converter is applied to a stable input voltage (e.g. strong batteries or to a stable DC micro-grid), a large inrush current occurs. The two windings N1 and N2 are in series and form the inductor L12. To get an easy idea of the inrush current, the load R1 and all parasitic losses are omitted. The inrush current can be described by

$$U_1 = L_{12} \frac{di}{dt} + \frac{1}{C_1} \int_0^t i dt. \quad (1)$$

To solve this differential-integral equation it is transformed by Laplace to

$$\frac{U_1}{s} = L_{12} s I(s) + \frac{1}{C_1} \frac{1}{s} I(s). \quad (2)$$

Rearranging to I(s) and back transformation leads to

$$i = U_1 \sqrt{\frac{C_1}{L_{12}}} \sin\left(\sqrt{\frac{1}{C_1 L_{12}}} t\right). \quad (3)$$

The peak current is given by

$$\hat{I} = U_1 \sqrt{\frac{C_1}{L_{12}}}. \quad (4)$$

The duration of this input peak is half of the period of the sinus wave (when the current reaches zero after a half period, the diode D2 turns off)

$$T_{IN} = \pi \sqrt{C_1 L_{12}}. \quad (5)$$

Fig. 2 shows the inrush, when the active switches S1 and S2 are blocked.

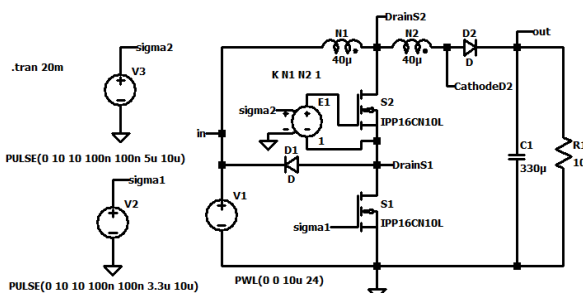

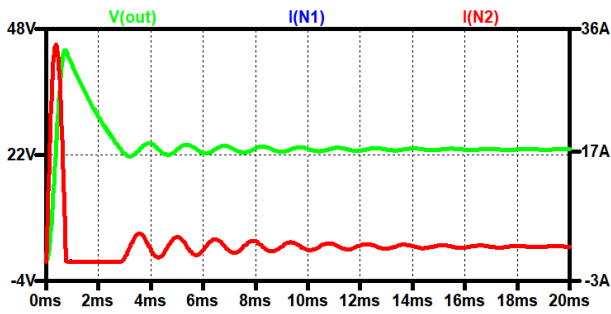

Fig. 2. Inrush: simulation circuit, (up tp down): inrush current (red) and output voltage (green).

The coupled windings form an inductor of 160  $\mu\text{H}$  (keep in mind that the inductance is proportional to the square of the number of turns). With the values of the components one gets

$$\text{Inrush frequency } f_{IN} = \frac{1}{2\pi\sqrt{160e-6 \cdot 330e-6}} = 693 \text{ Hz}$$

$$\text{Duration of the inrush peak } T_{IN} = \frac{1}{2f_{In}} = 722 \mu\text{s}$$

$$\text{Peak current } \hat{I}_{IN} = U_1 \sqrt{\frac{C_1}{L_{ges}}} = 34.5 \text{ A}$$

which are in good accordance with the simulation. The green line in Fig. 2 shows the output voltage. The capacitor is first charged up to about double of the input voltage and then discharged by the load resistor. When the voltage across the capacitor is lower than the input voltage, D2 turns on again and some damped ringing occurs.

### B. Modification of the converter according to Fig. 1

To avoid the inrush current a modification can be done. The capacitor C1 is not connected across the output, but between the positive input and the output connectors. With this small change not only the inrush current is avoided, but also the necessary voltage of the capacitor is reduced (which leads often to a cheaper capacitor). Fig. 3 shows the topology of the converter. In the continuous mode this converter has again the three modes as the original converter according to Fig. 1. Fig. 4 shows the simulation circuit and the inrush. The output voltage reaches nearly the input voltage and the current supplies the load and some ringing occurs.

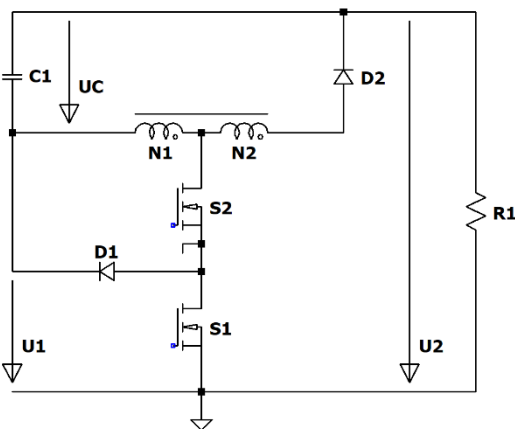

Fig. 3. Modified tri-state Boost converter with coupled coils.

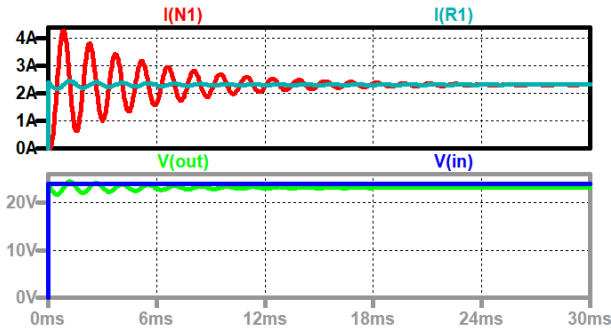

Fig. 4. Modified tri-state Boost converter with coupled coils, (up to down): inrush current (red) through winding N1, load current (turquoise); input voltage (blue), output voltage (green).

## II. BASIC ANALYSES OF THE MODIFIED TRI-STATE BOOST CONVERTER

The basic analyses are done with ideal components, that means no parasitic resistors, no forward voltage across the diodes and the transistors, and ideal switching of the semiconductor devices.

### A. Voltage transformation ratio

During steady-state the voltage across an inductor or across a magnetic winding must be zero in the mean. This characteristic can be used to achieve the voltage transformation ratio of the converter. The duty cycles of the switches  $d_1$  and  $d_2$  are the on-times of the respected switches referred to the switching period. The voltage time balance across N1

$$U_1 d_1 = |U_1 - U_2| \frac{N_1}{N_1 + N_2} (1 - d_2). \quad (6)$$

leads to

$$U_2 = \frac{d_1(N_1 + N_2) + (1 - d_2)N_1}{(1 - d_2)N_1} U_1, \quad d_1 \leq d_2, \quad (7)$$

$$U_C = U_1 \frac{d_1}{1 - d_2} \frac{N_1 + N_2}{N_1}, \quad d_1 \leq d_2. \quad (8)$$

For  $N_1 = N_2 = N$  one gets

$$U_2 = \frac{1 + 2d_1 - d_2}{1 - d_2} U_1, \quad d_1 \leq d_2, \quad (9)$$

$$U_C = 2 \frac{d_1}{1 - d_2} U_1, \quad d_1 \leq d_2. \quad (10)$$

For  $d_1 > d_2$  the converter works as a normal tapped inductor converter with the voltage time balance across N1 according to

$$U_1 d_2 = |U_1 - U_2| \frac{N_1}{N_1 + N_2} (1 - d_2) \quad (11)$$

and the output and the capacitor voltages according to

$$U_2 = \frac{d_2 N_2 + N_1}{N_1 (1 - d_2)} U_1, \quad (12)$$

$$U_C = \frac{d_2}{1 - d_2} \frac{N_1 + N_2}{N_1} U_1. \quad (13)$$

For  $N_1 = N_2 = N$  one gets

$$U_2 = \frac{1+d_2}{1-d_2} U_1, \quad (14)$$

$$U_C = 2 \frac{d_2}{1-d_2} U_1. \quad (15)$$

Fig. 5 shows the voltage transformation ratio in dependence on the duty cycles for a converter with a winding ratio of 1:1. The duty cycle of the second switch  $d_2$  must be higher than  $d_1$ . The diagram shows the stationary behavior. The curves show the duty cycle for  $d_2$  as parameter and  $d_1$  as variable. The duty cycle of switch S1  $d_1$  must be lower than  $d_2$ . One can notice that the graphs for the voltage transformation ratios with  $d_2$  as parameter are linear! The nonlinear graph is the voltage transformation ratio of a Boost converter with coupled coils and again with a winding ratio of 1:1.

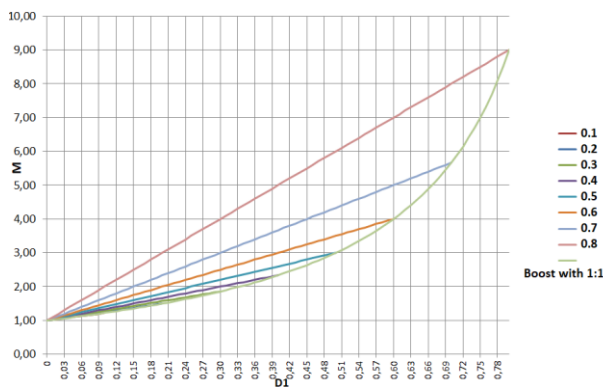

Fig. 5. Stationary voltage transformation ratio for  $N_1=N_2$  in dependence on  $d_1$  with  $d_2$  as parameter.

### B. Charge balance of the capacitor

The characteristic of a capacitor is the fact that the current through it is zero in the mean during steady-state. Therefore, one can write

$$I_R d_2 = \left( \bar{I}_{N2,3} - I_R \right) (1 - d_2) \quad (16)$$

and gets for the mean value of the current through  $N_2$  referred only to the off-time of S2

$$\bar{I}_{N2,3} = \frac{I_R}{1 - d_2}. \quad (17)$$

The mean value of the current through  $N_1$  referred to the duration of M1 is

$$\bar{I}_{N1,1} = \frac{I_R}{1 - d_2} \frac{N_1 + N_2}{N_2}. \quad (18)$$

The current ripple of the current through  $N_1$  during M1 depends on the input voltage and the inductivity, which is the  $A_L$ -value of the used core multiplied by the square of the number of windings

$$\Delta I_{N1} = \frac{U_1 d_1 T}{L_1} = \frac{U_1 d_1}{f L_1}. \quad (19)$$

leading to a peak current of

$$\hat{I}_{N1,1} = \frac{I_R}{1 - d_2} \frac{N_1 + N_2}{N_2} + \frac{U_1 d_1}{2 f L_1}. \quad (20)$$

Fig. 6 shows a steady state. When both switches are on, the current through N1 increases. When only S2 is on, the current is nearly constant (only the negative forward voltage of D1 and the very low on-voltage of the MOSFET S2 (also negative) is across N1) leading to only a very slow reduction of the current.

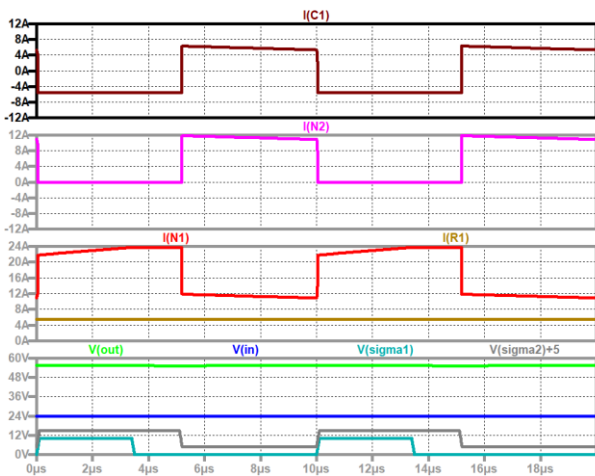

Fig. 6. Steady state (up to down): current through the capacitor (black); current through the second winding (violet); current through the first winding (red), load current (brown); output voltage (green), input voltage (blue), control signals for S2 (grey) and S1 (turquoise).

From Fig. 6 one can see that the coupled windings can be smaller. Fig. 7 and Fig. 8 show the steady state for smaller windings (both have 7.7 μH). They depict the current through the source, the current through the capacitor, the current through winding N1, the current through winding N2, the current through the diode D2, and the current through the diode D1, and the voltages across the components.

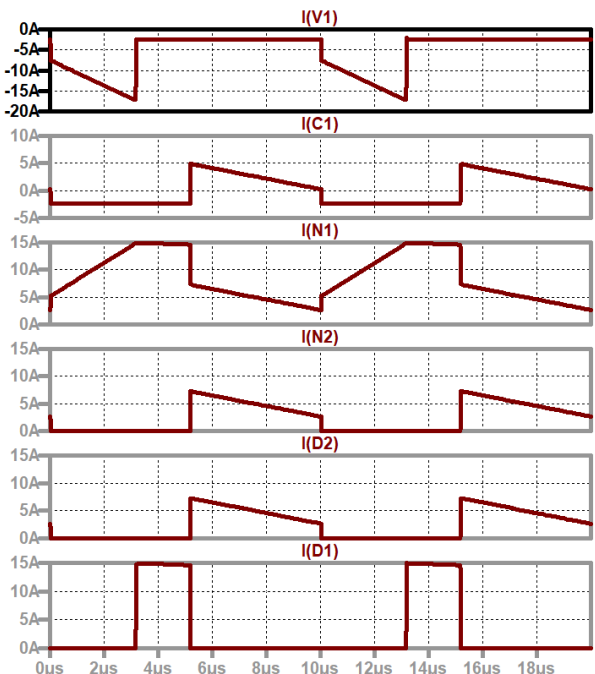

Fig. 7. Steady state (up to down):: current through the source (this current is negative because LTSpice counts current and voltage across a component always in the same direction), current through the capacitor, current through winding N1, current through winding N2, current through the diode D2, current through the diode D1.



It should be mentioned that, as for most step-up converters, the circuit is not short- and open-circuit proved. Fact is further that the coupled coils should have a low stray inductance to avoid over-voltages across the switches. Therefore, a winding ratio of one to one, realized by a bifilar winding, is advantageous. When other winding ratios are necessary, a recuperating turn-off snubber which feeds the energy, stored in the stray inductor, back to the source or to the output (c.f. e.g. [21, 22]) should be used.

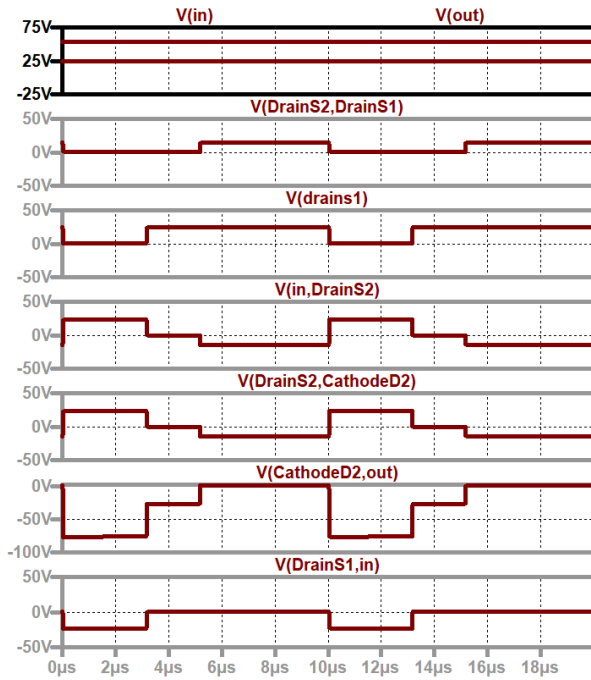

Fig. 8. Steady state, up to down: output voltage, input voltage; voltage across S2; voltage across S1; voltage across N1; voltage across N2; voltage across D2; voltage across D1.

### III. MODEL OF THE CONVERTER

The state variables are the flux connected to one turn and the voltage across the capacitor.

During M1 both active switches are on

$$\frac{d\phi}{dt} = \frac{u_1}{N_1}, \quad \frac{du_{C1}}{dt} = \frac{-(u_{C1} + u_1)/R_1}{C_1}. \quad (21)$$

During M2 S1 is off, S2 is on and the current through N1 is free-wheeling through D1

$$\frac{d\phi}{dt} = 0, \quad \frac{du_{C1}}{dt} = \frac{-(u_{C1} + u_1)/R_1}{C_1}. \quad (22)$$

The flux does not change and the load is supplied by the capacitor and the input source.

During M3 both active switches are turned off; the flux is now produced by both windings and the diode D2 transfers charge to the output. The state equations are now

$$\frac{d\phi}{dt} = \frac{-u_{C1}}{N_1 + N_2}, \quad \frac{du_{C1}}{dt} = \frac{i_{N2} - (u_{C1} + u_1)/R}{C_1}. \quad (23)$$

The flux is linked with the current and the proportional factor between flux and current is the inductance. For a given iron core with the value  $A_L$  (which depends on the air gap) one can write for the current

$$\psi = N\phi = Li, \quad i = \frac{N\phi}{L} = \frac{N\phi}{A_L N^2} = \frac{\phi}{A_L N}. \quad (24)$$

With

$$i_{N1} = i_{N2} = \frac{\phi}{A_L(N_1 + N_2)} \quad (25)$$

one can write for the second state equation in mode M3

$$\frac{du_{C1}}{dt} = \frac{\phi/[A_L(N_1 + N_2)] - (u_{C1} + u_1)/R}{C_1} \quad (26)$$

Mode M1 must be weighted by  $d_1$ , mode M3 must be weighted by  $(1-d_2)$  and the discharge of the capacitor by the load current is valid all the time. This leads to the large signal model

$$\frac{d}{dt} \begin{pmatrix} \phi \\ u_{C1} \end{pmatrix} = \begin{bmatrix} 0 & \frac{d_2 - 1}{N_1 + N_2} \\ \frac{1 - d_2}{A_L(N_1 + N_2)C_1} & -\frac{1}{RC_1} \end{bmatrix} \begin{pmatrix} \phi \\ u_{C1} \end{pmatrix} + \begin{bmatrix} \frac{d_1}{N_1} \\ -\frac{1}{RC_1} \end{bmatrix} (u_1) \quad (27)$$

Linearization leads to

$$\frac{d}{dt} \begin{pmatrix} \hat{\phi} \\ \hat{u}_{C1} \end{pmatrix} = \begin{bmatrix} 0 & \frac{D_{20} - 1}{N_1 + N_2} \\ \frac{1 - D_{20}}{A_L(N_1 + N_2)C} & -\frac{1}{RC} \end{bmatrix} \begin{pmatrix} \hat{\phi} \\ \hat{u}_{C1} \end{pmatrix} + \begin{bmatrix} \frac{D_{10}}{N_1} & \frac{U_{10}}{N_1} & \frac{U_{C10}}{N_1 + N_2} \\ -\frac{1}{RC_1} & 0 & -\frac{\Phi_0}{A_L(N_1 + N_2)C} \end{bmatrix} \begin{pmatrix} \hat{u}_1 \\ \hat{d}_1 \\ \hat{d}_2 \end{pmatrix} \quad (28)$$

With abbreviations

$$\frac{d}{dt} \begin{pmatrix} \hat{\phi} \\ \hat{u}_{C1} \end{pmatrix} = \begin{bmatrix} 0 & A_{12} \\ A_{21} & A_{22} \end{bmatrix} \begin{pmatrix} \hat{\phi} \\ \hat{u}_{C1} \end{pmatrix} + \begin{bmatrix} B_{11} & B_{12} & B_{13} \\ B_{21} & 0 & B_{23} \end{bmatrix} \begin{pmatrix} \hat{u}_1 \\ \hat{d}_1 \\ \hat{d}_2 \end{pmatrix} \quad (29)$$

one can write for the Laplace transformed equation

$$\begin{bmatrix} s & -A_{12} \\ -A_{21} & s - A_{22} \end{bmatrix} \begin{pmatrix} \Phi(s) \\ U_C(s) \end{pmatrix} + \begin{bmatrix} B_{11} & B_{12} & B_{13} \\ B_{21} & 0 & B_{23} \end{bmatrix} \begin{pmatrix} U_1(s) \\ D_1(s) \\ D_2(s) \end{pmatrix} \quad (30)$$

With the help of Cramer's law one can calculate the transfer functions (Fig. 9 till Fig. 14).

The denominator

$$Den = s^2 - A_{22}s - A_{12}A_{21} \quad (31)$$

is the same for all transfer functions. The numerators are different. The values used are  $C=330 \mu\text{F}$ ,  $N_1=N_2=12$ ,  $A_L=280\text{nH}$ ,  $A_{Fe}=289 \text{ mm}^2$ ,  $U_{10}=24 \text{ V}$ ,  $U_{C10}=28.8 \text{ V}$ ,  $U_{20}=52.8 \text{ V}$ ,  $R=10 \Omega$ ,  $\Phi_0=69 \mu\text{Vs}$ ,  $D_{10}=0.3$ ,  $D_{20}=0.5$ .

The numerator of the capacitor voltage in dependence on the duty cycle of switch S2  $d_2$  GUCD2 is

$$Num_{U_C D_2} = B_{23}s + A_{21}B_{13} \quad (32)$$

The zero is on the right side of the complex plane at

$$s_N = -\frac{A_{21}B_{13}}{B_{23}} = \frac{(1-D_{20})U_{C0}}{(N_1 + N_2)\Phi_0} \quad (33)$$

A smaller flux shifts the zero to the right and reduces its influence! The transfer function describes a non-phase-minimum system.

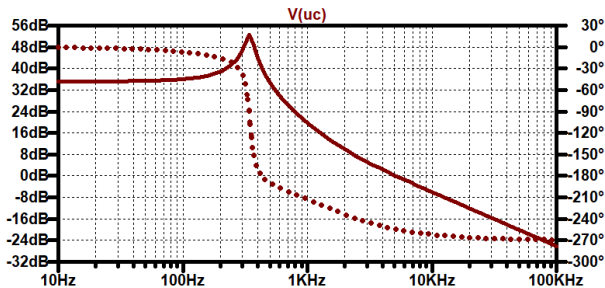

Fig. 9. Bode plot between capacitor voltage UC and duty cycle D2 (solid line: gain response, dotted line: phase response).

The numerator of the capacitor voltage in dependence on the duty cycle of switch S1 d1 GUCD1 is

$$Num_{UCD_1} = A_{21}B_{12} \quad (34)$$

The transfer function is a phase minimum system of second order.

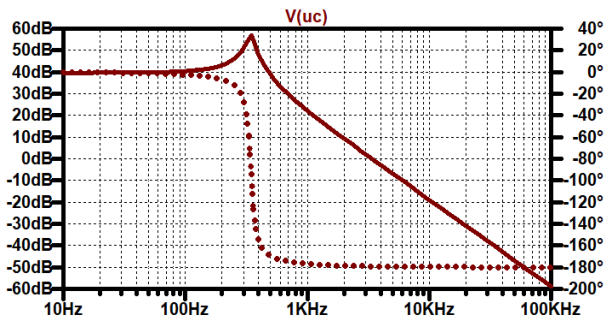

Fig. 10. Bode plot between capacitor voltage UC and duty cycle D1 (solid line: gain response, dotted line: phase response).

The numerator of the capacitor voltage in dependence on the input voltage GUCU1 is

$$Num_{UCU_1} = B_{21}s + A_{21}B_{11} \quad (35)$$

The transfer function is now a non-phase minimum system of second order (Fig. 11). The influence of the right half plane zero is low (the frequency of the zero is at about 3.1 kHz).

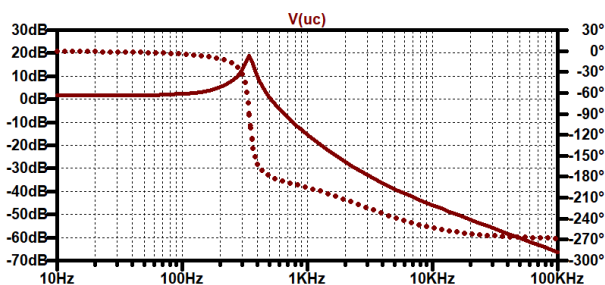

Fig. 11. Bode plot between capacitor voltage UC and the input voltage U1 (solid line: gain response, dotted line: phase response).

To control the output voltage one will choose a constant duty cycle  $d_2$  and control the converter with the duty cycle  $d_1$ . A phase-minimum system is easier to control than a non-phase-minimum system (the positive zero leads to an additional phase shift of -90 degrees).

The numerator of the flux in dependence on the duty cycle of switch S2  $d_2$  GPHID2 is

$$Num\_PHID_2 = B_{13}s + A_{12}B_{23} - A_{22}B_{13}. \quad (36)$$

This transfer function (Fig. 12) has a zero on the left side at

$$s_N = \frac{-\left[ \frac{(1-D_{20})\Phi_0}{A_L(N_1+N_2)C} + \frac{U_{C0}}{RC} \right]}{U_{C0} - U_{10}}. \quad (36)$$

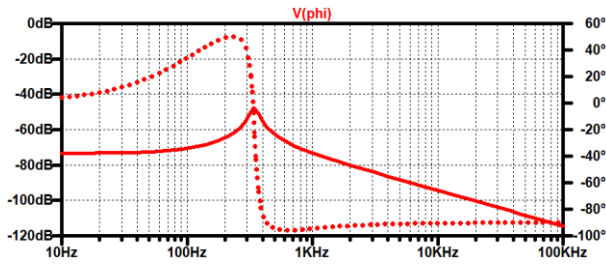

Fig. 12. Bode plot between flux PHI and duty cycle D2 and flux density and duty cycle D2 (red) (solid line: gain response, dotted line: phase response).

The numerator of the flux in dependence on the duty cycle of switch S1 GPHID1 is

$$Num\_PHID_1 = B_{12}s - A_{22}B_{12}. \quad (37)$$

One can calculate the position of the zero according to

$$s_N = \frac{A_{22}B_{12}}{B_{12}} = A_{22} = -\frac{1}{RC}. \quad (38)$$

In this graph (Fig. 13) not only the flux is shown, but also the flux density

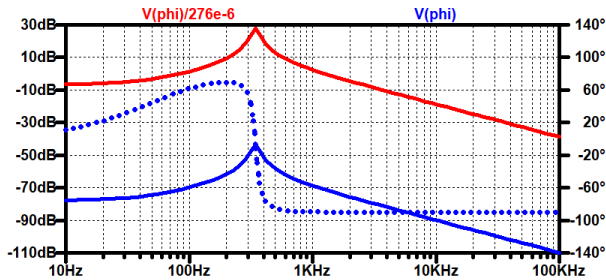

Fig. 13. Bode plot between flux PHI and duty cycle D2 (blue) and flux density and duty cycle D2 (red) (solid line: gain response, dotted line: phase response).

The numerator of the flux in dependence on the input voltage GPHIU1 is

$$Num\_PHIU_1 = B_{11}s + A_{12}B_{21} - A_{22}B_{11}. \quad (39)$$

The zero is again on the left side.

$$s_N = \frac{A_{22}B_{11} - A_{12}B_{21}}{B_{11}} = -\frac{1}{RC_1} \left[ 1 + \frac{N_1}{N_1+N_2} \frac{1-D_{20}}{D_{10}} \right]. \quad (40)$$

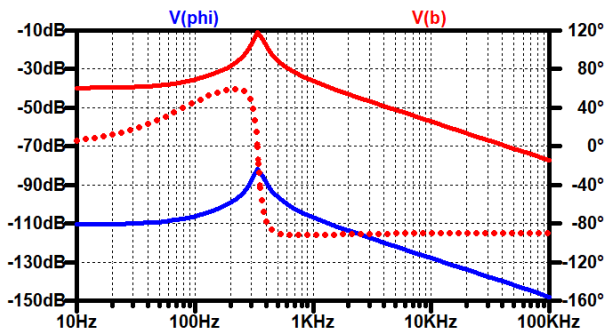

Fig. 14. Bode plot between flux PHI (blue) and flux density (red) (solid line: gain response, dotted line: phase response).

## IV. SIMULATIONS

A comparison of the input current of the tri-state Boost and the modified tri-state Boost with coupled coils are shown in Fig. 15.

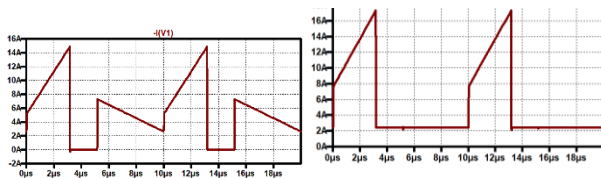

Fig. 15. Input current: left: converter according to Fig. 1, right: converter according to Fig. 3.

The soft-start and the reaction of changes of the duty cycle are shown in Fig. 16. The duty cycles for the two switches are increased slowly during start-up to achieve a soft-start and no current overshoot occurs. The reaction of the currents through the windings and of the output voltage can be seen for steps of the duty cycle  $d_1$ .

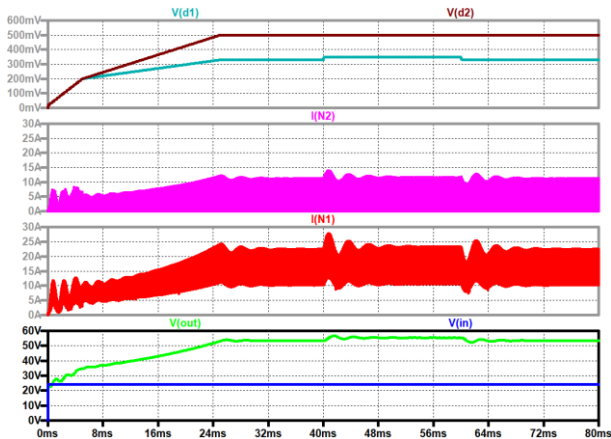

Fig. 16. Start-up and duty cycle steps, up to down: duty cycle of switch S2 (black), duty cycle of switch S1 (turquoise); current through N2 (violet); current through N1 (red); output voltage (green), input voltage (blue).

## V. OTHER MODIFICATIONS TO GET A MODIFIED TRI-STATE BOOST CONVERTER WITH COUPLED COILS

### A. Replacement of diode D1

To reduce the losses during the short circuit of N1, a current bidirectional active switch can replace the diode D1 (Fig. 17). This switch S3 is turned on, when switch S1 is turned off. If it is turned on later, the parallel diode (in case of a MOSFET the body diode) turns on and the current can free-wheel.

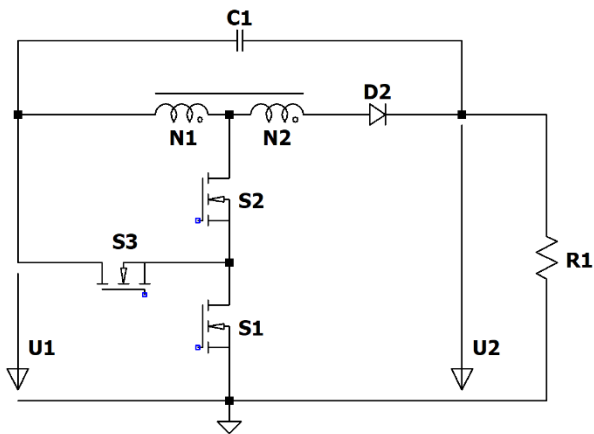

Fig. 17. Tri-state Boost converter with coupled coils with replaced diode D1 by a current bidirectional active switch S3.

*B. Replacement of diode D2*

To reduce the onward losses of the converter, diode D2 can also be replaced by a current bidirectional switch S4 (Fig. 18). S4 is turned on, when S2 is turned off. To avoid a short circuit, a small dead-time between the turn off of S2 and the turn-on of S4 is used. In the case when both diodes are replaced by current bidirectional switches, the converter is now bidirectional and energy can be transferred from the input side to the output side and also the other way around.

When working from the output to the input side S4, S2 and S1 are turned on to magnetize N2. When S4 is turned off, the current through N2 commutates into N1 and energy is transferred into the input source or free-wheels through S3, when this switch is turned on. Another way to control the circuit during back operation is when S1 and S2 are off. When S4 is turned on, both windings get magnetized. When S4 turns off, the current commutates from N2 also into N1, energy is fed back and the circuit is closed by the body diodes of S1 and S2 (which can be turned on to reduce losses). A third mode can be achieved by turning on S3.

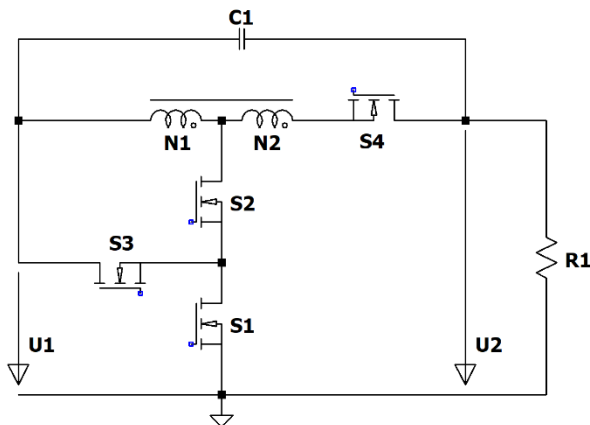

Fig. 18. Tri-state Boost converter with coupled coils, replaced diodes by current bidirectional active switches.

*C. Cascaded converter*

When higher output voltages are to be produced, converters can be connected in series. Fig. 19 shows two modified tri-state converters in series (with diodes, but naturally they can be replaced by active switches).

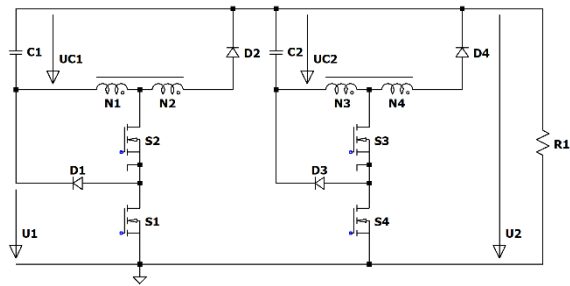

Fig. 19. Cascaded tri-state modified Boost converters with coupled coils.

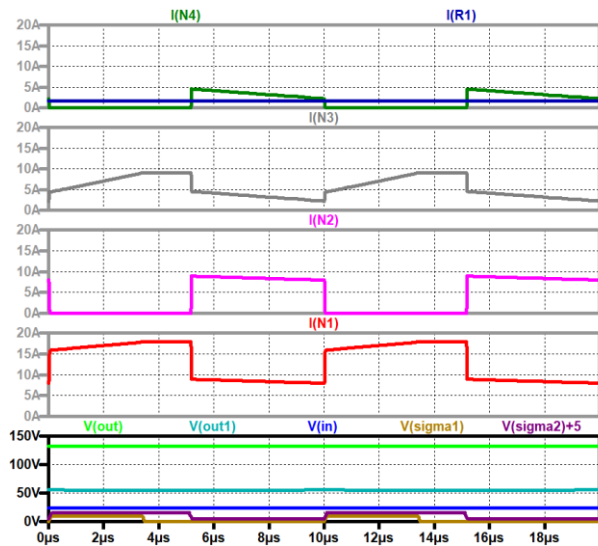

Fig. 20. Cascaded tri-state modified Boost converters with coupled coils in steady-state, (up to down): current through N4 (dark green), load current (dark blue); current through N3 (grey); current through N2 (violet); current through N1 (red); output voltage (green), output of stage 1 (turquoise), input voltage (blue), control signal for S2 (dark violet), control signal for S1 (brown).

Fig. 20 shows the cascaded converter in the steady state. The currents through the four windings are drawn in the same scale. Furthermore, the output voltage, the input voltage and the control signals of the switches S1 and S2 are depicted. In the simulation the two switches of the second stage are driven by the same signals.

### D. Little change in the topology variant I

To reduce the on-losses the position of S2 and D1 can be changed (Fig. 21). Now current is flowing only through S1 during mode M1 and not through both active switches.

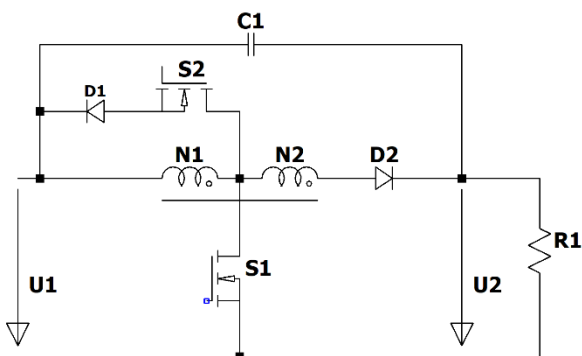

Fig. 21. Modification of the topology variant I.

Diode D1 and the second switch S2 are in series and in parallel to the winding N1. This reduces the losses during M1. S2 can be turned on during the on-time of S1, but the current through it starts only after S1 is turned off.

Fig. 22 show the input current, the current through the second winding, the current through the first winding, the output voltage, the input voltage, the control signal for S2, and the control signal for S1 in steady-state.

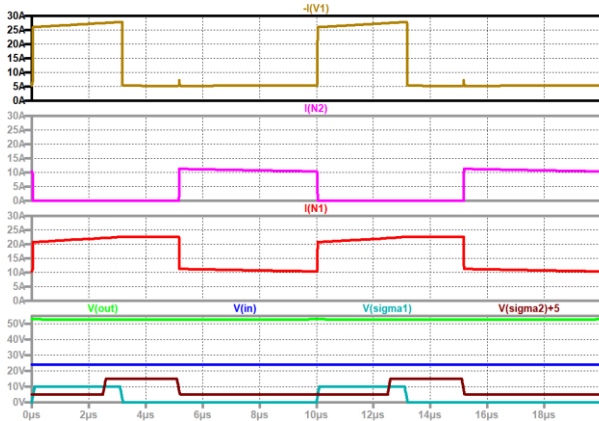

Fig. 22. Variant I according Fig. 21 (up to down): input current (brown); current through the second winding (violet); current through the first winding (red); output voltage (green), input voltage (blue), control signal for S2 (black), control signal for S1 (turquoise).

### E. Little change in the topolgy variant II

The diode D1 is replaced by a third active switch S3 which is anti-serial to the switch S2. Both can be turned on and off together, so only one high side driver is necessary. Transistors with low onward resistor have lower losses than the diode. Therefore, the efficiency of the converter can be improved. The switches which make the short circuit of N1 must not be turned on, when the main switch S1 is on! The circuit diagram is shown in Fig. 23.

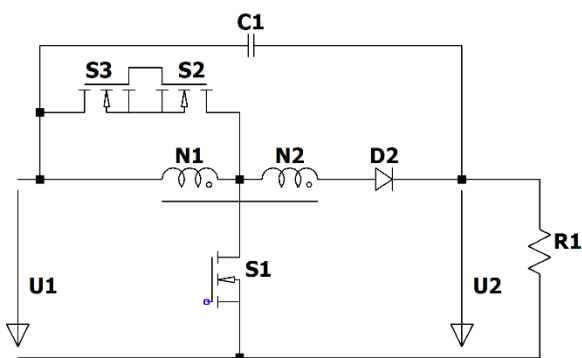

Fig. 23. Modification of the topolgy variant II.

Fig. 24 shows the input current, the current through the second winding, the current through the first winding, the output voltage, the input voltage, the control signal for S2, and the control signal for S1 in steady-state.



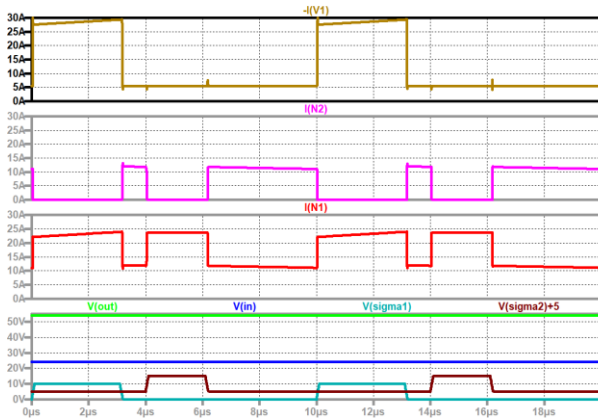

Fig. 24. Variant II according Fig. 23 (up to down): input current (brown); current through the second winding (violet); current through the first winding (red); output voltage (green), input voltage (blue), control signal for S2 (black), control signal for S1 (turquoise)

## VI. CONCLUSIONS

The modified Boost converter with coupled inductors has several interesting features:

- No inrush current, when applied to a stable input voltage source
- Additional degree of freedom in the voltage transformation ratio
- Reduced voltage stress across the capacitor
- Linearized voltage transformation ratio
- Phase minimum system for constant duty cycle of the second switch
- Continuous input current
- High step-up ratios possible

Some interesting modifications of the converter are shown. The converter is especially useful for driving loads which need a higher supply voltage in DC micro grids or in cars (electro mobility).

## References

- [1] M. A. Vaghela and M. A. Mulla, "Tri-State Coupled Inductor Based High Step-Up Gain Converter Without Right Hand Plane Zero," in *IEEE Transactions on Circuits and Systems II: Express Briefs*, vol. 70, no. 6, pp. 2291-2295, June 2023, doi: 10.1109/TCSII.2023.3237679.
- [2] N. Mohan, T. Undeland and W. Robbins, *Power Electronics, Converters, Applications and Design*, 3rd ed. New York: W. P. John Wiley & Sons, 2003.
- [3] F. Zach, *Power Electronics*, in German: *Leistungselektronik*, Frankfurt: Springer, 6th ed., 2022.
- [4] Y. Rozanov, S. Ryvkin, E. Chaplygin, P. Voronin, *Power Electronics Basics*, CRC Press, 2016.
- [5] F. A. Himmelstoss, "Concept to change the voltage transformation ratio of a DC/DC converter," *CUKUROVA 9th INTERNATIONAL SCIENTIFIC RESEARCHES CONFERENCE*, October 9-11, 2022, Adana, Turkey, pp. 258-273, ISBN: 978-625-8246-28-5.
- [6] A. Choubey and L. A. C. Lopes, "A tri-state 4-switch bi-directional converter for interfacing supercapacitors to DC micro-grids," *2017 IEEE 8th International Symposium on Power Electronics for Distributed Generation Systems (PEDG)*, Florianopolis, Brazil, 2017, pp. 1-6, doi: 10.1109/PEDG.2017.7972507.

- [7] Q. Wang, A. Choubey and L. A. C. Lopes, "Mode Transition for Increased Voltage Gain Range of a 4-Switch DC-DC Converter with Tri-State and Single Duty Cycle Control," 2021 IEEE 12th International Symposium on Power Electronics for Distributed Generation Systems (PEDG), Chicago, IL, USA, 2021, pp. 1-6, doi: 10.1109/PEDG51384.2021.9494256.
- [8] Q. Wang and L. A. C. Lopes, "Multi-Mode PWM Modulator for a 4-Switch DC-DC Converter Operating with Tri-State," 2023 IEEE 17th International Conference on Compatibility, Power Electronics and Power Engineering (CPE-POWERENG), Tallinn, Estonia, 2023, pp. 1-6, doi: 10.1109/CPE-POWERENG58103.2023.10227409.
- [9] G. R. Broday, G. Damm, W. Pasillas-Lépine and L. A. C. Lopes, "Modeling and dynamic feedback linearization of a 5-switch tri-state buck-boost bidirectional DC-DC converter," 2021 22nd IEEE International Conference on Industrial Technology (ICIT), Valencia, Spain, 2021, pp. 427-432, doi: 10.1109/ICIT46573.2021.9453569.
- [10] K. Viswanathan, R. Oruganti and D. Srinivasan, "Dual-mode control of tri-state boost converter for improved performance," in IEEE Transactions on Power Electronics, vol. 20, no. 4, pp. 790-797, July 2005, doi: 10.1109/TPEL.2005.850907.
- [11] K. Viswanathan, R. Oruganti and D. Srinivasan, "A novel tri-state boost converter with fast dynamics," in IEEE Transactions on Power Electronics, vol. 17, no. 5, pp. 677-683, Sept. 2002, doi: 10.1109/TPEL.2002.802197.
- [12] S. K. Viswanathan, R. Oruganti and D. Srinivasan, "Dual mode control of tri-state boost converter for improved performance," IEEE 34th Annual Conference on Power Electronics Specialist, 2003. PESC '03., Acapulco, Mexico, 2003, pp. 944-950 vol.2, doi: 10.1109/PESC.2003.1218182.
- [13] S. Sarkar, A. Ghosh and S. Banerjee, "Design and implementation of type-III controller in tri state boost converter," 2015 Annual IEEE India Conference (INDICON), New Delhi, India, 2015, pp. 1-6, doi: 10.1109/INDICON.2015.7443152.
- [14] K. Viswanathan, R. Oruganti and D. Srinivasan, "Tri-state boost converter with no right half plane zero," 4th IEEE International Conference on Power Electronics and Drive Systems. IEEE PEDS 2001 - Indonesia. Proceedings (Cat. No.01TH8594), Denpasar, Indonesia, 2001, pp. 687-693 vol.2, doi: 10.1109/PEDS.2001.975402.
- [15] S. Kapat, A. Patra and S. Banerjee, "A novel current controlled tri-state boost converter with superior dynamic performance," 2008 IEEE International Symposium on Circuits and Systems, Seattle, WA, USA, 2008, pp. 2194-2197, doi: 10.1109/ISCAS.2008.4541887.
- [16] K. Kumar, N. Rana, S. Banerjee, S. B. Santra and N. Parvez, "Design and analysis of soft-switched tri-state boost converter," 2018 International Conference on Power, Instrumentation, Control and Computing (PICC), Thrissur, India, 2018, pp. 1-6, doi: 10.1109/PICC.2018.8384792.
- [17] O. Knecht, D. Bortis and J. W. Kolar, "ZVS Modulation Scheme for Reduced Complexity Clamp-Switch TCM DC-DC Boost Converter," in IEEE Transactions on Power Electronics, vol. 33, no. 5, pp. 4204-4214, May 2018, doi: 10.1109/TPEL.2017.2720729.
- [18] V. Michal, D. Cottin and P. Arno, "Boost DC/DC converter nonlinearity and RHP-zero: Survey of the control-to-output transfer function linearization methods," 2016 International Conference on Applied Electronics (AE), Pilsen, Czech Republic, 2016, pp. 1-10, doi: 10.1109/AE.2016.7577229.
- [19] S. Sarkar and S. S. Ghosh, "Traditional IMC & IMC Based PID Controller Design for Tri-State Boost Converter," 2020 IEEE 9th Power India International Conference (PIICON), Sonapat, India, 2020, pp. 1-6, doi: 10.1109/PIICON49524.2020.9112992.
- [20] N. Rana and S. Banerjee, "Interleaved Tri-state Buck-Boost Converter with Fast Transient Response and Lower Ripple," 2019 IEEE Transportation Electrification Conference (ITEC-India), Bengaluru, India, 2019, pp. 1-5, doi: 10.1109/ITEC-India48457.2019.ITECINDIA2019-199.

[21] F. A. Himmelstoss, "Modified Boost Converter with additional Boehringer network," 10th INTERNATIONAL ZEUGMA CONFERENCE ON SCIENTIFIC RESEARCH, June 25-26, 2023/ Gaziantep, Turkey, pp. 404-411, ISBN: 978-625-367-178-5.

[22] F. Himmelstoss and M. Windisch, "Tapped inductor Boost with exploitation of the stray energy," 2022 IEEE 20th International Power Electronics and Motion Control Conference (PEMC), Brasov, Romania, 2022, pp. 75-80, doi: 10.1109/PEMC51159.2022.9962849.



## IMPLEMENTATION AND TESTING OF A SOLAR DECLINATOR WITH WATER PREHEATING

**P. Sivaraj, K.S.Naveen and Dr C. M. Raguraman**

Department of Mechanical Engineering, Faculty of Engineering and Technology, Annamalai University, India

### ABSTRACT

The primary aim of this study was to develop a novel approach for obtaining drinking water in arid regions that are severely affected by droughts, by utilising brackish water sourced from pre-existing wells. The study focused on developing an active solar desalination unit, which aimed to preheat water using a flat solar collector, and subsequently perform boiling desalination through an evaporation and condensation chamber.

A prototype active solar desalination unit was constructed, utilising Ferro-cement and masonry collector to desalinate brackish water. The unit composed of a flat solar collector, which is used to preheat water, and an evaporation and condensation chamber, which perform the boiling desalination process. Upon conducting several tests, it was observed that the unit produced an average of 3.3 litres of desalinated water per square metre on a daily basis.



### ELECTRIC VEHICLE CHARGER BASED ON PID CONTROLLER

**Youness Hakam<sup>1</sup>, Ahmed Gaga<sup>2</sup>, Benachir El Hadadi<sup>2</sup>**

Research Laboratory of Physics and Engineers Sciences (LRPSI), Research team in Embedded Systems Engineering, Automation, Signal, Telecommunications and Intelligent Materials (ISASTM), Department of Physics, Polydisciplinary Faculty (FPBM), Sultan Moulay Slimane University (USMS), Beni-Mellal, Morocco

#### ABSTRACT

As the usage of electric vehicles (EVs) continues to rise worldwide, the proliferation of EV chargers is becoming increasingly common. The interaction between vehicle-to-grid (V2G) and grid-to-vehicle (G2V) presents complex challenges within the realm of the Smart Grid. Precise management of power exchange between EVs and the grid is essential to effectively regulate the quality of the Smart Grid's power supply. The integration of vehicle-to-grid technology necessitates the use of specialized electric vehicle battery chargers that enable bidirectional power transfer between the power grid and the EV battery.

In light of these considerations, this paper introduces a novel control strategy for bidirectional battery chargers. This proposed control strategy enables both the charging and discharging of electric vehicle batteries in Constant Current (CC) and Constant Voltage (CV) modes. The charging process involves drawing power from the grid via a bidirectional AC-DC inverter and a cascaded DC-DC converter. The inverter's operations are governed by a PID controller, generating Sinusoidal Pulse Width Modulation (SPWM) for charging and discharging operations. Additionally, the converter is regulated to charge the battery with a specified current reference, employing another PID controller. By utilizing current and State of Charge (SOC) references, the battery charging process ensures that the SOC can be accurately adjusted according to the user's preferences. this process has been simulated in MATLAB-Simulink.

**Keywords:** PID controller; AC-DC Inverter, DC-DC converter. MATLAB-Simulink, Vehicle-to-Grid, Grid-to-Vehicle.



### SOLAR CHARGING SYSTEM BASED ON ARTIFICIAL NEURAL NETWORK

Hajar ahessab <sup>1\*</sup>, Ahmed Gaga<sup>2</sup>, Benachir El Hadadi<sup>2</sup>

Research Laboratory of Physics and Engineers Sciences (LRPSI), Research team in Embedded Systems Engineering, Automation, Signal, Telecommunications and Intelligent Materials (ISASTM), Department of Physics, Polydisciplinary Faculty (FPBM), Sultan Moulay Slimane University (USMS), Beni-Mellal, Morocco

#### ABSTRACT

In a hybrid renewable energy system leveraging photovoltaic technology, batteries play a pivotal role as energy storage. This system operates under two distinct scenarios: stable conditions, where the photovoltaic (PV) system generates energy, and unstable conditions, where energy is simultaneously generated by both the PV system and the batteries. This paper proposes the design of a charging circuit for lithium-ion batteries, tailored to maintain the maximum power point (MPP) across a range of variable solar radiation levels spanning 0 to 1000 W/m<sup>2</sup>, while operating at a consistent temperature of 25°C. The control of the converter is achieved through the utilization of Artificial Neural Network (ANN) and Perturb and Observe (P&O) techniques, ensuring precise regulation of the output voltage from the solar panels to match the battery's nominal voltage. To validate the proposed approach, a simulation-based investigation was conducted using the MATLAB/Simulink toolset.

**Keywords:** ANN controller; P&O algorithm; DC-DC converter. MATLAB-Simulink.



### ANALYSIS OF REDUCED SWITCH MULTILEVEL INVERTERS FOR ELECTRIC VEHICLE APPLICATIONS

**R Tamizh Selvan, Dr V Thiagarajan**

Department of Electrical & Electronics Engineering, Sri Sivasubramaniya Nadar College of Engineering,  
Kalavakkam – 603 110, Chennai, Tamil Nadu, INDIA

#### ABSTRACT

The efficient and compact design of multilevel inverters (MLI) serves as a driving force across various applications, notably in solar photovoltaic (PV) systems and electric vehicles (EVs). Multilevel inverters have garnered increasing attention as they strive to meet specific requirements and offer an attractive alternative for delivering high-quality power. They present a range of advantages, including a reduced device count, operation at lower switching frequencies, decreased  $dv/dt$  stress, and lower harmonic distortions. Recent advancements in multilevel inverter topologies have led to designs with fewer components compared to conventional inverters like the flying capacitor type (FC), cascaded H-bridge type (CHB), and neutral point clamped type (NPC). The number of components in the circuit is directly linked to the number of levels in the multilevel inverter, which can increase both cost and structural complexity. In the case of FC MLI and NPC MLI, maintaining capacitor voltage balance presents a formidable challenge, limiting them to five levels and preventing further cascading. This limitation results in an output voltage that is only half of the input voltage, leading to higher switching frequencies and increased losses. To address these issues, a wide range of research efforts has been dedicated to reducing the component count in multilevel inverters, resulting in the proposal of various topologies tailored to different levels, each with its unique set of challenges. In this study, a novel multilevel inverter architecture utilizing a switched capacitor approach is presented. The proposed configuration is distinguished by its simplicity and ease of implementation, especially for higher-level applications. A key advantage is the reduced number of active switches, resulting in a corresponding reduction in driver circuitry. This reduction translates into cost savings, reduced device count, and a smaller overall MLI footprint. In the context of solar energy systems, the integration of solar panels, alongside a perturb and observe (P&O) algorithm, ensures a stable DC voltage. Furthermore, a single input and multi-output converter is employed to boost the DC link voltage. A comprehensive comparative analysis is conducted, encompassing parameters such as switch count, gate driver boards, source count, diode and capacitor quantities, and overall component count. For the proposed MLI configurations, simulation results are meticulously aligned with experimental data. The total harmonic distortion (THD) consistently remains below 5%, conforming to IEEE standards. To corroborate our findings, we have implemented a hardware prototype in our laboratory, subjecting it to dynamic load variations, while the simulations have been executed using MATLAB/Simulink.

**Keywords:** Multilevel Inverter, Reduced switch count, Symmetrical, Asymmetrical, Photovoltaic, P&O algorithm, THD



## AN ENSEMBLE HARD VOTING MODEL FOR ELECTRICAL FAULT DETECTION

Oğuzhan KATAR

Research Assistant, Firat University, Faculty of Technology, Department of Software Engineering, Elazığ-Türkiye  
(Responsible Author) ORCID: 0000-0002-5628-3543

Özal YILDIRIM

Assoc. Prof., Firat University, Faculty of Engineering, Department of Artificial Intelligence and Data Engineering, Elazığ-Türkiye  
ORCID: 0000-0001-5375-3012

### ABSTRACT

Electrical faults are abnormalities or malfunctions in an electrical system that can disrupt its normal operation. They can be caused by factors such as overloading circuits or equipment, insulation breakdown, short circuits, loose connections, and equipment failure, leading to potential electrical hazards or system failures. While methods such as visual inspections, using multimeters, and thermography have traditionally been employed to identify abnormal temperature patterns and detect these faults. Manual detection can be challenging due to the need for trained personnel, time-consuming inspections, and the potential for human error. This makes it less reliable for large or complex electrical systems. However, machine learning methods offer the advantage of automating the detection of electrical faults by analyzing vast amounts of data, identifying subtle patterns indicative of faults. This paper proposes an ensemble hard voting model designed for the automatic detection of electrical faults. This ensemble model incorporates five distinct machine learning classifiers: decision tree (DT), random forest (RF), support vector machine (SVM), logistic regression (LR), and K-nearest neighbors (KNN). The ensemble model's final output is determined through the implementation of a hard voting strategy on the predictions generated by each individual model. To validate the effectiveness of our proposed ensemble model, we conducted experiments on a publicly available dataset comprising 12,001 samples of current and voltage values from a 3-phase system. Our training phase utilizes 80% of the dataset, with the remaining 20% reserved for testing. Our experimental results demonstrate that the proposed ensemble model attains an impressive accuracy rate of 99.75%, with just six misclassifications observed in the test data. The proposed model has the potential to be an efficient tool for the detection of electrical faults due to its high accuracy and low cost.

**Keywords:** electrical faults, ensemble model, hard voting, automatic detection, machine learning.

### Introduction

An electrical fault refers to any anomaly or malfunction in an electrical circuit or system that can disrupt its normal operation and potentially result in equipment damage, power outages, or safety hazards (Furse et al., 2020). Electrical faults can arise from various causes and are generally classified into two primary categories: symmetric faults and asymmetric faults (Rivas & Abrao, 2020).

Symmetric faults occur when the fault current is equally distributed across all three phases of a three-phase electrical system. These faults typically result from a short circuit between conductors or a ground fault where the fault current is uniformly distributed among the phases (Raj & Bhattacharjee, 2020). Symmetric faults are generally easier to analyze and remediate because the fault currents are evenly distributed across all phases, making it simpler to predict the behavior of the electrical system during the fault condition.

Conversely, asymmetric faults, also referred to as unbalanced faults, occur when the fault current is unevenly distributed across different phases of a three-phase electrical system. These faults often result from irregular or asymmetrical conditions within the electrical system (Tu'uau et al., 2020). Asymmetric faults can be more challenging to analyze and may lead to unpredictable system behavior. They are also more difficult to diagnose and remediate because they create unbalanced conditions in the electrical system, which can result in voltage imbalances, increased stress on equipment, and potential damage to the system.



Electrical faults are generally detected by experts through a combination of visual inspections, testing equipment, and expertise. These experts perform visual inspections of electrical components and wiring to identify signs of wear, damage, or overheating, such as discolored insulation or burnt connections (Rajawat et al., 2022). They also use a variety of testing tools, including multimeters and circuit testers, to measure voltage, current, and resistance at various points in the electrical system to pinpoint abnormalities. In addition, experts perform insulation resistance tests to identify potential insulation breakdowns. This process relies on the experience and knowledge of specialists to recognize irregularities and diagnose electrical faults accurately, ensuring the safety and reliability of electrical systems (Yao et al., 2021).

However, machine learning methods have the potential to detect electrical faults more effectively than traditional methods (Alimi et al., 2020). This is because machine learning algorithms can analyze vast amounts of data from sensors and historical records to identify patterns indicative of faults, even in complex and hidden issues. Machine learning models can detect faults by training on labeled datasets containing examples of both normal and faulty electrical behavior. They can then classify new data based on these learned patterns. Additionally, machine learning can continuously monitor electrical systems in real-time, providing early detection and predictive maintenance capabilities, thus reducing downtime and improving safety.

Electrical fault detection using machine learning-based ensemble methods is a subject of considerable research interest, yet the number of studies utilizing such methods is limited. In this study, we propose an ensemble hard voting model for the automatic detection of electrical faults. The model incorporates five distinct machine learning classifiers: decision tree (DT), random forest (RF), support vector machine (SVM), logistic regression (LR), and K-nearest neighbors (KNN). The predictions generated by each individual model are aggregated through a hard voting strategy, resulting in a more accurate and robust final output.

The primary contributions of this study are as follows:

- A system that detects the presence of electrical faults without the need for expensive hardware is presented.
- The use of a hard voting strategy enhances the accuracy and robustness of the model by combining the individual predictions of multiple classifiers.
- Our research expands the application of ensemble methods in the field of electrical fault detection, providing a versatile framework that can be adapted for various electrical systems.

## Materials and Methods

In this paper, we propose an ensemble model that is specifically designed for the automatic detection of electrical faults. The proposed model utilizes both current and voltage measurements as input, and employs a combination of five distinct machine learning classifiers to predict the presence or absence of electrical faults. These classifiers include DT, RF, SVM, LR, and KNN. The predictions generated by each classifier are subsequently combined through a hard voting strategy, resulting in a final output that is both accurate and reliable. Figure 1 depicts the block diagram of the proposed method.

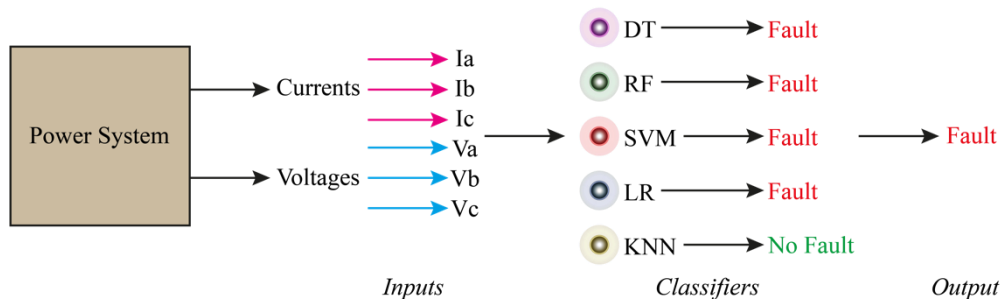

**Figure 1.** The proposed hard voting method

### Dataset

In this study, a public dataset containing 12,001 samples was utilized (Electrical Fault Detection and Classification, 2021). The dataset was obtained from a power system modeled in the MATLAB environment. The dataset comprises of 6 distinct classes, namely:

1. Line-Line (LL) Fault
2. Line-Ground (LG) Fault
3. Line-Line-Ground (LLG) Fault
4. Line-Line-Line-Ground (LLLG) Fault
5. Line-Line-Line (LLL) Fault
6. No Fault

In this study, the focus was solely on detecting the presence or absence of electrical faults, leading to the consolidation of five fault classes into a single class. The class-based distribution of the organized dataset is presented in Figure 2. The dataset comprises of 7 columns in total, with 6 of them being numerical characteristics, namely Ia, Ib, Ic, Va, Vb and Vc. The remaining column is a label value (0 or 1) indicating the presence or absence of a fault.

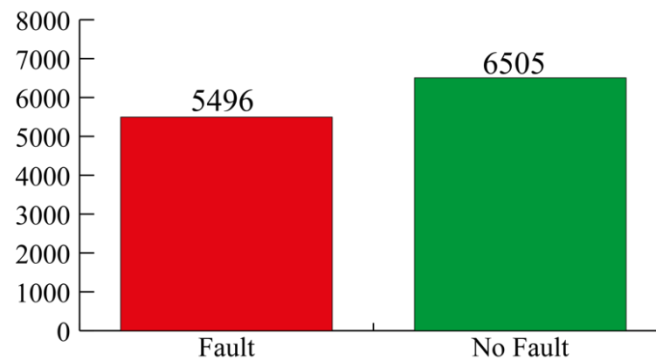

**Figure 2.** Distribution of dataset samples

### Hard Voting Ensemble Model

An efficacious voting ensemble model, which utilizes multiple individual classifiers to arrive at a definitive decision, has been implemented in this investigation. Each classifier in the ensemble submits its prediction, and the most populous vote among them determines the ultimate output. The classifiers incorporated in this study can be summarized as follows:

- DT partition data into subsets based on feature conditions, forming a tree-like structure, and make predictions by traversing the tree (Zenga & Colapinto, 2023).
- RF combines multiple DT to reduce overfitting and improve generalization by constructing a forest of trees and aggregating their predictions through majority voting (Fawagreh et al., 2014).
- SVM aim to find the hyperplane that best separates different classes in the data, and are particularly effective in high-dimensional spaces (Erfani et al., 2016).
- LR models the probability of a data point belonging to a particular class using a logistic function, and can handle both numerical and categorical features (Maalouf, 2011).
- KNN is a non-parametric classification algorithm that assigns a data point to the class most common among its K nearest neighbors in the feature space (Peterson, 2009).

**Performance Evaluation**

Evaluating the performance of our ensemble model requires a thorough examination using multiple metrics and the confusion matrix. This matrix provides an in-depth analysis of true positives (TP), true negatives (TN), false positives (FP), and false negatives (FN). The standard structure of a two-class confusion matrix is presented in Figure 3.

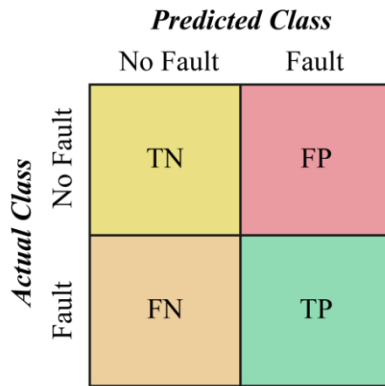

**Figure 3.** Two-class structure of the confusion matrix

Various performance metrics are calculated using the confusion matrix elements. These metrics and their mathematical equations are given in Table 1.

**Table 1.** Performance evaluation metrics

Measures	Description	Equation
Accuracy (Acc)	Accuracy is the ratio of correctly classified instances to the total number of instances.	$\frac{TP + TN}{TP + FP + FN + TN}$
Precision (Pre)	Precision measures the proportion of correctly predicted positive instances out of all instances predicted to be positive.	$\frac{TP}{TP + FP}$
Recall (Rec)	Recall measures the proportion of correctly predicted positive instances out of all actual positive instances.	$\frac{TP}{TP + FN}$
F-1 Score	The F1 score is the harmonic mean of precision and recall.	$\frac{2 * (Pre * Rec)}{(Pre + Rec)}$

**Experimental Results**

The proposed ensemble hard voting model was trained using 80% of the dataset samples, utilizing the default hyper-parameters of the classifiers. The training processes were carried out in the Python 3.10.11 version within the Google Colab environment. Subsequently, the model was tested using unseen test data, and the predictions made by the model were recorded. The confusion matrix of the predictions is presented in Figure 4.

*Hard Voting Model*

	0	1
0	1323	1
1	5	1072

**Figure 4.** Test phase results

The proposed model demonstrated an impressive level of accuracy by achieving a 99.75% accuracy rate on the test data, with only 6 misclassifications out of 2401 instances. However, the model experienced difficulty in certain instances, specifically when predicting "no fault" when the actual class was "fault". The performance rates of the proposed model in the test phase are given in Figure 5.

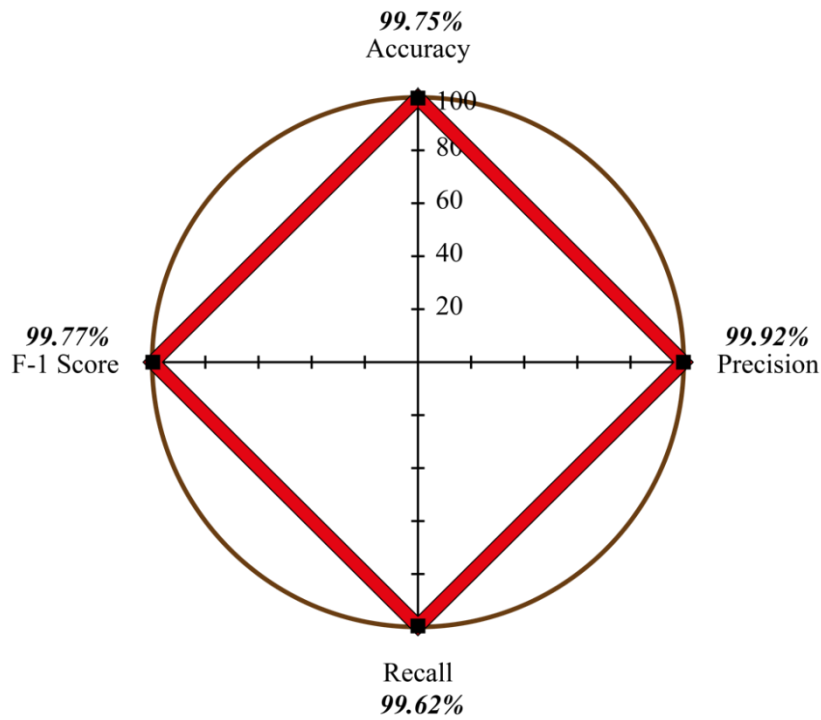

**Figure 5.** The performance rates of the test predictions

**Conclusions**

Our study has demonstrated the potential of machine learning techniques in automating the detection of electrical faults within complex systems. Electrical faults pose significant risks to both equipment and personnel, making their early detection and mitigation crucial. Traditional methods of fault detection, while effective to some extent, have limitations in terms of scalability, reliability, and time efficiency. The ensemble

hard voting model we proposed in this study, combining five machine learning classifiers (Decision Tree, Random Forest, Support Vector Machine, Logistic Regression, and K-Nearest Neighbors), has proven to be highly effective. Our experiments on a dataset of 12,001 samples of current and voltage values from a 3-phase system revealed an outstanding accuracy rate of 99.75%. The model exhibited remarkable performance, with only six misclassifications in the test data. These results indicate that our ensemble model has the potential to significantly improve the efficiency and accuracy of electrical fault detection in various settings, from industrial complexes to residential electrical systems. Its automation capabilities not only reduce the reliance on manual inspections but also enhance the overall safety and reliability of electrical systems.

## References

- Alimi, O. A., Ouahada, K., & Abu-Mahfouz, A. M. (2020). A review of machine learning approaches to power system security and stability. *IEEE Access*, 8, 113512–113531.
- Erfani, S. M., Rajasegarar, S., Karunasekera, S., & Leckie, C. (2016). High-dimensional and large-scale anomaly detection using a linear one-class SVM with deep learning. *Pattern Recognition*, 58, 121–134.
- Electrical Fault detection and classification. (2021, May 22). Kaggle. <https://www.kaggle.com/datasets/esathyaprakash/electrical-fault-detection-and-classification/>
- Fawagreh, K., Gaber, M. M., & Elyan, E. (2014). Random forests: from early developments to recent advancements. *Systems Science & Control Engineering: An Open Access Journal*, 2(1), 602–609.
- Furse, C. M., Kafal, M., Razzaghi, R., & Shin, Y.-J. (2020). Fault diagnosis for electrical systems and power networks: A review. *IEEE Sensors Journal*, 21(2), 888–906.
- Maalouf, M. (2011). Logistic regression in data analysis: an overview. *International Journal of Data Analysis Techniques and Strategies*, 3(3), 281–299.
- Peterson, L. E. (2009). K-nearest neighbor. *Scholarpedia*, 4(2), 1883.
- Raj, R. D. A., & Bhattacharjee, S. (2020). Short-Circuit Fault Analysis of Three-Phase Grid Integrated Photovoltaic Power System. *2020 International Conference on Power Electronics & IoT Applications in Renewable Energy and Its Control (PARC)*, 231–236.
- Rajawat, A. S., Goyal, S. B., Bedi, P., Mihaltan, T. C., Neagu, B.-C., Raboaca, M. S., & Verma, C. (2022). Electrical fault detection for industry 4.0 using fusion deep learning algorithm. *2022 International Conference and Exposition on Electrical And Power Engineering (EPE)*, 658–662.
- Rivas, A. E. L., & Abrao, T. (2020). Faults in smart grid systems: Monitoring, detection and classification. *Electric Power Systems Research*, 189, 106602.
- Tu'uau, D. Y., Marica, T., & Assaf, M. (2020). Electric power system fault analysis. *WSEAS Transactions on Circuits and Systems*, 19(3), 19–27.
- Yao, L., Fang, Z., Xiao, Y., Hou, J., & Fu, Z. (2021). An intelligent fault diagnosis method for lithium battery systems based on grid search support vector machine. *Energy*, 214, 118866.
- Zenga, M., & Colapinto, C. (2023). 3 Decision Tree for. *Engineering Mathematics and Artificial Intelligence: Foundations, Methods, and Applications*, 53.

## GÜÇ SİSTEMLERİNDE MAKİNE ÖĞRENMESİ İLE ELEKTRİK ARIZA TESPİTİ

**Ozan TURANLI**

System Engineer, GDZ Electrical Energy inc. Bornova İzmir-Türkiye  
(Responsible Author) ORCID: 0009-0000-3723-7528

**Yurdagul Bentesen YAKUT**

Research Assistant, Dicle University, Faculty of Engineering, Department of Engineering Diyarbakir-Türkiye,  
ORCID0000-0003-3236-213

### ÖZET

Modern güç sistemlerinde elektriğin üretiminden konutlara iletimine kadar olan süreçte sürekliliğin sağlanması esastır. Genel olarak elektriğin üretimi, iletimi ve dağıtımı simetrik bir yapıya sahiptir. Üç fazlı sistemlerde iletkenler arasındaki gerilim ile her bir fazdan geçen akım mutlak değer olarak eşittir. Tek fazlı yükler üç fazın her birine eşit olarak dağıtılır. Ancak üç fazlı simetrik kısa devre oluşumu dışında, elektrik sisteminde dengesiz yükler veya iletken değerler, iletken ve toprak gibi arızalar, iletkenlerin kendi aralarında kısa devre oluşması, faz iletkenlerinin simetrik olmayan akımlar akması gibi nedenlerle elektrik sisteminde farklı büyüklükte gerilimler. Sonuç olarak enerji sabit, kesintisiz veya aynı frekansta olamaz. Bu istenmeyen senaryonun önüne geçebilmek için elektrik güç sistemlerinin nominal çalışma koşullarının ve arızalarının iyi anlaşılması gerekmektedir. Enerji sistemi modellerinin anlaşılmasını kolaylaştırmak için bilgisayar arayüzlerini kullanır.

Bu motivasyonla çalışma, güç sistemlerinde elektrik arıza tespitinin makine öğrenmesi ile sınıflandırılmasını amaçlamaktadır. Pilot bölge için enerji sisteminin modeli bir grup araştırmacı tarafından MATLAB/Simulink platformunda oluşturulmuş ve veri seti internette kullanıma sunulmuştur. Bu modelle elde edilen veri seti bu çalışmaya dayanmaktadır. Makine öğrenimi, bir bilgisayarın doğrudan talimatlar olmadan öğrenmesine yardımcı olmak için matematiksel modelleri kullanma sürecidir. Yapay sinir ağları yöntemi makine öğrenmesi kapsamında yer alan bir yöntemdir. Yapay sinir ağları, doğrusal olmayan ve karmaşık girdi ve çıktı verileri arasındaki ilişkileri öğrenme ve modelleme yeteneğine sahiptir. Bu nedenle bu çalışmada yapay sinir ağları yöntemi tercih edilmiştir. Hat akımları ve gerilimleri, çeşitli arıza senaryoları ve bir arızanın gerçekten meydana gelip gelmediği için veri setine dahil edilir. Çalışmada örnek modelden elde edilen veri setleri ile bir arızanın olup olmadığı yapay sinir ağı yöntemiyle tespit edilmiştir. Simülasyon tabanlı veri seti eğitim ve test olmak üzere iki sete ayrılmıştır. Ağımız eğitim veri seti kullanılarak eğitildi ve test seti performansını değerlendirmek için kullanıldı. Sonuçlar çeşitli kriterler ışığında gözden geçirildi ve en az hata içeren sonuçlar değerlendirildi. Gözlem sonucunun düşük çıkması durumunda farklı mimariler denenerek en başarılı model belirlendi.

**Anahtar Kelimeler:** Güç Sistemi, Arıza Tespiti; Sınıflandırma, Makine Öğrenmesi

### 1. Giriş

İletim hattı, güç sisteminin en önemli parçasıdır. Güç gerekliliği ve bağılılığı modern çağda katlanarak artmaktadır. Bir iletim hattının öne çıkan rolü, elektrik enerjisini kaynak bölgeden dağıtım şebekesine iletmesidir. Elektrik güç sistemi, çok sayıda etkileşimli öğeden kaynaklı olarak bozulmaya veya arızalanmaya eğilimli bir dinamik yapıdır. Yüksek kapasiteli elektrik üretim santrallerinde ve şebekelerde, stabil kalabilmek için mümkün olan en kısa sürede arızanın tespiti ve koruma ekipmanlarının çalıştırılması gerekmektedir.

Elektrik güç sisteminin iletim hatlarındaki arızalarının öncelikle tespit edilip doğru sınıflandırılması ve mümkün olan en kısa sürede sorunun giderilmesi gerekmektedir. Bu aşamada iletim hattında arıza tespiti ve kontrolü ise işleme alınan öncelikli iş paketi olarak karşımıza çıkar. Arızaların kısa devreden kaynaklı veya yıldırım, deprem gibi doğa olaylarından kaynaklı olduğu kayıtlardan görülmektedir. Oluşabilecek arızaların önceden tespit edilmesi veya tespit edildiği gibi olaya müdahale edilmesi; enerji iletiminin kesintisiz olarak sürdürülebilirliğini artırmakla birlikte, oluşabilecek maddi sıkıntıların önüne geçebilecektir. Arızaların ilk

aşamada tespiti, söz konusu sıkıntıların hızlı müdahalesine olanak sağlayacaktır. Bu motivasyonla, bu çalışmada elektrik arızalarının tespiti amaçlanmış olup, araştırmacıların erişimine açık olan bir veri seti üzerinden farklı sınıflandırma yaklaşımları ile başarımlarını performansları değerlendirilmiştir. Sınıflandırma amaçlı kullanılan makine öğrenmesi yöntemlerinin başarılı olabilmesi, ancak sistemin dengesiz bir durumda olması ile mümkündür ki bu durum simetrik ve asimetrik kategori olarak adlandırılır. Çoğunlukla iletim hattında asimetrik arızalar meydana gelir; L-G Arızası (tekli hat toprak arızası) ve L-L Arızası (Hat Hat arızası). Bu çalışmada arıza var / yok olacak şekilde bir sınıflandırma yapılmış olup, arıza tespiti için kullanılan sınıflandırma yöntemi olarak farklı makine öğrenmesi yaklaşımları kullanılmıştır. (Janarthanam K, Kamallesh P et al, 2022).

## 2. Literatür Çalışmaları

İletim hatlarındaki güç kalitesinin artırılması; hatanın tespiti ve sınıflandırılması ile ilişkilidir. Bu minvalde (N. A. M. Leh, F. M. Zain, Z. Muhammad et al., 2022). çalışmasında, yapay sinir ağları kullanılarak, güç kalitesi iyileştirilmiş ve iletim hatlarında görülen soru çözüme kavuşturulmuştur. Öncelikle empedans tekniği ile hata oluşturulmuş ve çeşitli uyarımlar (stimulation) ile akım/gerilimler ölçülmüştür. Çalışmada, ileri besleme geri yayılım algoritması kullanılarak iletim arızalarının tespiti ve sınıflandırılması gerçekleştirilmiştir. Tespit ve sınıflandırma performansında %100 doğruluk oranı ile arıza tespit işlemi gerçekleştirilmiş ve sınıflandırma performansının ise %70 olduğu görülmüştür.

Diğer bir çalışmada, elektrik iletim sisteminden alınan gerçek arıza kayıtları öncelikle tasarlanan filtreden geçirilmiş ve ardından ayrık dalgacık enerjisi hesaplanmıştır. Elde edilen veriler yapay sinir ağı ile arıza tespiti yapılmıştır. Farklı örnekleme frekansları ile elde edilen verilerin başarı performanslarının [%92 %94] aralığında olduğu görülmüştür. (Ömer Faruk Ertuğrul et al., 2011).

Derin öğrenme destekli yapılan diğer bir çalışmada, arızanın tespiti için LSTM (uzun kısa süreli bellek) ağı önerilmiştir. Arızanın sınıflandırılması için akım değişkeni, ağına girişine uygulanmıştır. Önerilen modelin gürbüzlüğünü artırmak amacıyla, giriş işaretine Gaussian gürültüsü eklenmiştir. Yapılan simülasyon çalışmasında, toplam 11 sınıf üzerinde çalışılmış olup, 0 çıkışı ile arıza olmadığı ve 1-10 arası ise 10 farklı arıza sınıfını işaret ettiği belirtilmiştir. Önerilen model ile %100 oranında tespit ve sınıflandırma işleminin yapıldığı görülmüştür. (Abdul Malek Saidina Omar et al., 2020).

## 3. Materyal ve Metod

### 3.1 Veri Seti

Bu çalışmada MATLAB Simulink tabanlı simülasyon çerçevesinde oluşturulan "Electrical Fault detection and classification" etiketli kaggle veri seti kullanılmıştır (Jamil M., Sharma S.K et al., 2015). Arıza analizini simule etmek için MATLAB'da bir güç sistemi modellenmiş ve Şekil 1'de gösterilen güç sisteminde her bir çift iletim hattının her iki ucuna 11000V'luk 4 jeneratör konumlandırılmıştır. Transformatörler çeşitli arızaları simule etmek ve incelemek için iletim hattının orta noktasına konumlandırılmıştır. Devre normal koşullar altında ve çeşitli arıza koşulları altında simule edilmiş ve güç sisteminin çıkışında hattın gerilim ve akım değerleri kayda alınmıştır. Veri seti için yaklaşık 12000 veri noktası kayda alınmış ve etiketlenmiştir (Jamil M., Sharma S.K et al., 2015). Üç fazın gerilim ve akımlarından oluşan toplam altı giriş (Ia, Ib, Ic, Va, Vb, Vc), oluşturulan makine öğrenmesi modellerinin girişine uygulanmıştır.

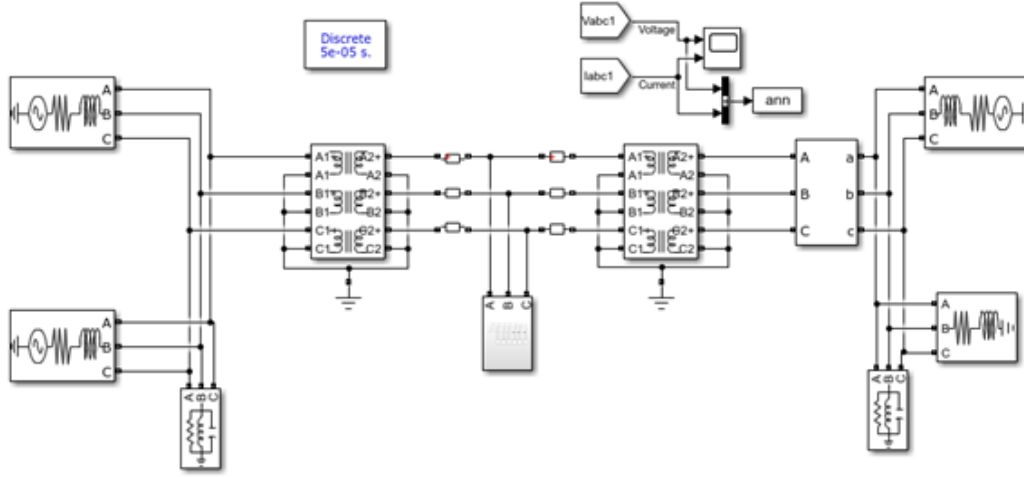

Şekil 1 . İletim hattının MATLAB/Simulink modeli kullanılmıştır(Jamil M., Sharma S.K et all., 2015).

Arıza öncesi ve sonrası üç faz gerilim ve akım değerleri farklıdır ve arıza türüne göre farklılık arz eder. Kullanılan veri setinin gerilim ve akım değerleri incelendiğinde, gerilim ve akım genliklerinin normal ve arıza durumlarında nasıl bir değişime girdikleri Şekil 2’de gösterilmiştir. Giriş gerilim değerleri sırasıyla arıza öncesi değerlerine göre normalize edildi. Şekil 2a gerilim normalize edilmiş değerleri ile grafik çizilmiştir.

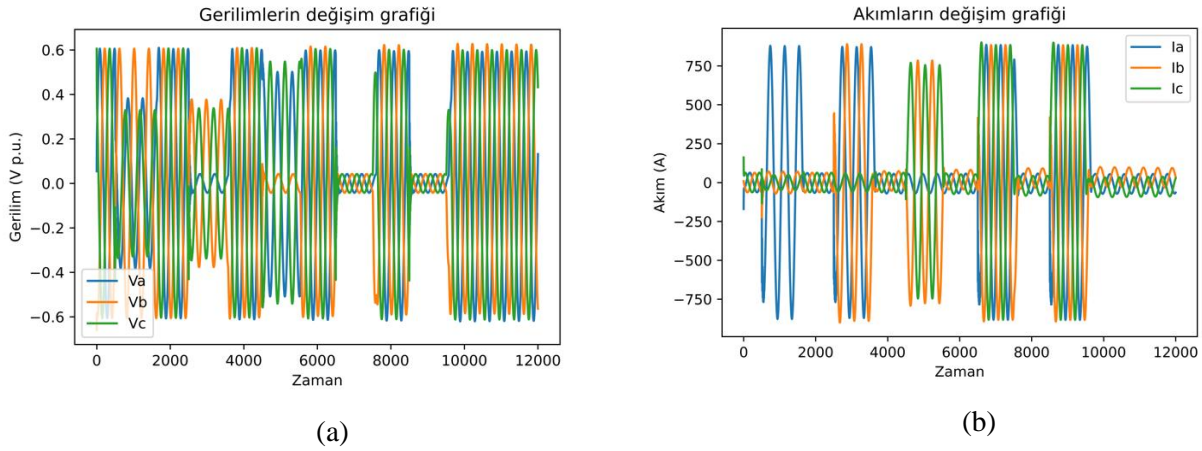

Şekil 2. (a) Üç fazlı gerilimin normal ve arıza durumlarındaki değişim örnekleri (b) Üç fazlı akımın normal ve arıza durumlarındaki değişim örnekleri

### 3.2 Önerilen Arıza Tespit Modeli

Önerilen arıza sistem model taslağı Şekil 3’de gösterilmiştir. Modelde görüldüğü üzere, üç faz gerilim ve akım değerleri modelin giriş parametreleri olup, çıkışta iletim hattında arızanın var olup olmadığı tespit edilmiştir.

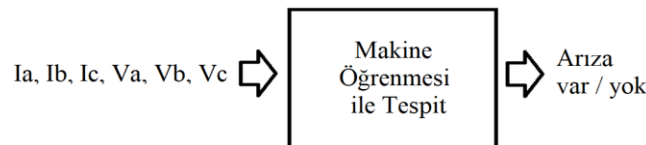

Şekil 3. Oluşturulan model taslağı. Arızanın var / yok durumu, modelde 0: normal, 1: arıza olarak etiketlenmiştir.



Giriş verileri öncelikle normalizasyona tabi tutulmuştur.

		Tahmin değerleri	
		Doğru	Yanlış
Gerçek değerler	Doğru	DP	YN
	Yanlış	YP	DN

hesabı her bir giriş parametresine

uygulanarak, her parametrenin ortalaması sıfır ve standart sapması bir olacak yapıya dönüştürülmüştür ve dolayısıyla veri seti yeniden ölçeklendirilmiştir. Ölçeklenen veriler, oluşturulan makine öğrenmesi modellerinin girişine uygulanmıştır.

12001 tane örüntüden oluşan veri setinin %80'lik kısmı (9600 örüntü) eğitim için ve kalan %20'lik kısım (2400 örüntü) ise test için ayrılmıştır. Eğitim verisinin ayrıca modele göre %20'si doğrulama veri seti olarak ayrılmıştır. Oluşturulan modellerin detayları bir sonraki bölümde kısaca açıklanmıştır.

**a) K-En Yakın Komşu Algoritması (KNN):** Parametrik olmayan sınıflandırma ve regresyon algoritmasıdır. Basit bir matematiksel temele sahip olmakla birlikte, uygulanabilme kolaylığı olması nedeniyle tahmin modellerinde sıklıkla tercih edilmektedir. Bu algoritmanın amacı, test veri setinde yer alan ve sınıfı bilinmeyen bir örneğin eğitim veri setindeki örneklerle olan uzaklığını ölçerek sınıflandırmaktır (Düzgün Akmaz, 2022). Öklit, Chebyshev, Manhattan ve Minkowski gibi uzaklık ölçüleri, KNN uygulamalarında görülebilen mesafe fonksiyonlarıdır. Bu yöntemin tüm eğitim veri setinin depolanması için geniş bir alana ihtiyaç duyması, sistem belleği açısından maliyetli olmaktadır.

Çalışmada uzaklık ölçütü olarak Öklit kullanılmakla birlikte, komşuluk k değeri farklı değerlerde (3,5,7,9,11,13,..) denenmiştir. Analiz sonunda en iyi performansın  $k=3$ 'de elde edildiği tespit edilmiştir.

**b) Destek Vektör Makinesi (SVM):** Yöntem; sınıflandırma ve örüntü tanıma problemlerinin çözümü için Vapnik tarafından geliştirilmiştir (Sevgi AYHAN et al., 2014). Sınıfları birbirinden ayıracak optimal ayırma hiper düzleminin elde edilmesi, yöntemin temel amacıdır. Bu işlem, farklı sınıflara ait destek vektörleri arasındaki uzaklığın maksimize edilmesi ile sağlanır (Wu X, Kumar V et al., 2008). Verileri doğrusal olarak ayrılabilir forma dönüştürmek için, verilerin giriş uzayından daha yüksek boyutlu bir öznitelik uzayına doğrusal olmayan dönüşümüne olanak sağlayan ve iç çarpıma dayanan uygun bir çekirdek (kernel) fonksiyonu tanımlanır (Cortes, C et al., 1995). Bu çalışmada; lineer, sigmoid, polynomial ve radial basis çekirdek fonksiyonları denenmiş olup, en iyi performansı radial basis çekirdek fonksiyonunun verdiği tespit edilmiştir.

**c) Naive Bayes (NB) Sınıflandırma:** Bu tahmin yöntemi, Bayes teoremine dayalı basit bir olasılık tabanlı sınıflandırma yöntemi olup, olasılık tabanlı olarak bir olayın gerçekleşme ihtimalini hesaplar (Emrah Aydemir et al., 2021) ,(Mustafa SU et al., 2023). Denetimli öğrenmeye dayalı çalışan bu yöntemde, her bir nitelik sınıf içerisindeki diğer niteliklerden bağımsız olduğu kabul edilir. Koşullu olasılık ile önceki olayların bilgileri göz önüne alınarak, başka olayların gerçekleşebilme olasılığı hesaplanabilmektedir.

**d) LSTM Derin Öğrenme Modeli:** Özyinelemeli Sinir Ağlarının (Recurrent Neural Network-RNN) özel bir türü olan Uzun-Kısa Süreli Bellek (Long-Short Term Memory-LSTM), derin öğrenme alanında kullanılan yapay bir yinelemeli sinir ağı mimarisidir. RNN ürettiği her çıkışı bir önceki adıma bağlı olarak ilerlemesini sağlar ki bu durum, önceki adımlarda hesaplanan sonuçların bellekte tutulmasını gerektirir. Mimari yapısından kaynaklı olarak RNN'de kısa vadeli bellek olması nedeniyle uygulamalarda beklenen performansı sağlayamamaktadır. Ayrıca hesaplama sürecinde gradyan değerinin küçülmesi nedeniyle, LSTM ve GRU (Geçitlenmiş Özyinelemeli Birimler) mimarileri önerilmiştir (Jing Xia et al., 2019). LSTM'in kapsamında yer alan Cell State ile örüntülere ilişkin öznitelik bilgileri hücreler boyunca taşınır ki bu durum mimarinin belleği olarak açıklanabilir. Bu mimari yaklaşım, kısa süreli bellek probleminin çözümünü sağlar. Cell State için gerekli bilgiler kapılar tarafından sağlanır (Şekil 4a).

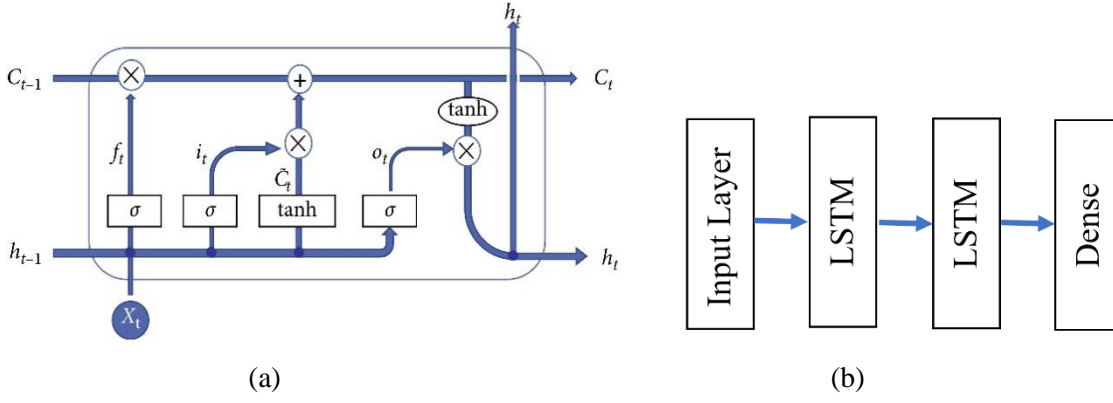

Şekil 4. (a) LSTM ağının mimari yapısı (Jing Xia et al., 2019). (b) çalışmada kullanılan model

Şekilden görüldüğü üzere mimaride; unut, girdi ve çıktı olmak üzere 3 kapı yer almaktadır. Unut kapısı, gelen bilginin unutulup unutulmayacağına karar veren birimdir. Girdi kapısı, bellekte depolanacak bilgiye karar veren birimdir ve çıktı kapısı ise hangi bilginin çıkışa aktarılacağını belirleyen birim olarak görev alır. LSTM mimarisinin literatürde hem tahmin ve hem de sınıflandırma amacıyla kullanılabildiği ve yüksek performans sergilemesi nedeniyle sıklıkla tercih edildiği görülmektedir.

Bu çalışmada LSTM mimarisi, sınıflandırma amaçlı kullanılmış ve farklı LSTM modelleri denenerek, en iyi performans veren mimari tespit edilmeye çalışılmıştır. Çalışmada en iyi performansa sahip olan LSTM modeli iki katmandan oluşmaktadır. Her katmanda sırasıyla bulunan nöron sayısı 4 ve 32 dir (Şekil 4b). Sonuçlar Tensorflow paketi ile Keras framework kullanılarak elde edilmiştir. Eğitim işlemi 100 iterasyon, ikili sınıflandırmada kayıp fonksiyonu olarak ikili çapraz entropi (binary cross entropy), ağırlıkların güncelleme amacıyla optimizasyon algoritması olarak Adam fonksiyonu ve aktivasyon fonksiyonu olarak sigmoid tercih edilmiştir.

### 3.3 Modelde Performans Ölçütleri

Literatürde, sınıflandırma modellerinin doğruluğunu belirlemek için farklı performans ölçütleri kullanılır. Bu çalışmada karmaşıklık (hata) matrisi ile birlikte elde edilen parametreler (doğruluk oranı, hassasiyet, duyarlılık ve F1 skoru) ve ROC eğrisi altında kalan AUC değeri modellerin başarı ölçütleri olarak değerlendirilmiştir. Karmaşıklık tahmin matrisi Tablo 1’de gösterilmiş olup, diğer gerekli açıklamalar aşağıda verilmiştir.

Tablo 1. Örnek karmaşıklık matrisi tablosu ve açıklamaları (J. P. Tan et al., 2022).

	Tahmin değerleri	
	Doğru	Yanlış
Gerçek değerler	Doğru	Yanlış
	Yanlış	Doğru

Doğru Pozitif (DP): Gerçek değeri pozitif olup, pozitif olarak tahmin edilenler  
Yanlış Negatif (YN): Gerçek değeri pozitif olup, negatif olarak tahmin edilenler  
Yanlış Pozitif (YP): Pozitif olarak tahmin edilmiş gerçek değeri negatif olanlar  
Doğru Negatif (DN): Negatif olarak tahmin edilmiş gerçek değeri negatif olanlar

Karmaşıklık matrisi kullanılarak elde edilen kategorik değerler, başarı ölçüt parametreleri olarak bilinir ki matematiksel ifadeleri denklem (1-4) de verilmiştir (Mustafa SU et al., 2023).

$$\text{Doğruluk Oranı (Accuracy)} = \frac{DP+DN}{DP+YN+YP+DN} \quad (1)$$

Doğruluk oranı; oluşturulan modelin hedef sınıflarını hangi oranda tahmin edebildiğini ifade eder.

$$\text{Kesinlik (Precision)} = \frac{DP}{DP+YP} \quad (2)$$

Kesinlik; oluşturulan model ile elde edilen sonucun ne kadar doğru olduğunu gösterir.

$$\text{Duyarlılık (Recall)} = \frac{DP}{DP+YN} \quad (3)$$

Duyarlılık; oluşturulan modelin doğru örnekleri bulma yeteneğini gösterir.

$$\text{F1 skoru (F1 Score)} = \frac{2 \cdot \text{Kesinlik} \cdot \text{Duyarlılık}}{\text{Kesinlik} + \text{Duyarlılık}} \quad (4)$$

F1 skoru; kesinlik ve duyarlılığın harmonik ortalamasını ifade eder.

#### 4. Bulgular

Oluşturulan her dört model için yapılan sınıflandırma çalışması ile elde edilen sonuçlar bu bölümde açıklanmıştır. KNN, SVM, NB ve LSTM modelleri ile elde edilen performans ölçütleri Tablo 2’de gösterilmiştir.

**Tablo 2.** KNN, SVM, NB ve LSTM modelleri başarı performansları

	Doğruluk Oranı (%)	Kesinlik (%)	Duyarlılık (%)	F1-Skoru (%)	AUC (%)
KNN	99.4	99.9	99	99.4	99.3
NB	97.7	100	95.9	97.9	97.4
SVM	97.8	100	96.2	98.1	97.6
LSTM	99.2	99.9	98.7	99.3	99.1

Sınıflandırma sürecinde denemeler neticesinde en iyi performans sergileyen yöntemler (KNN, SVM, NB ve LSTM) ile elde karmaşıklık matrisleri Tablo 3’de gösterilmiştir.

Tablo 3. Oluşturulan modellerin karmaşıklık matrisleri

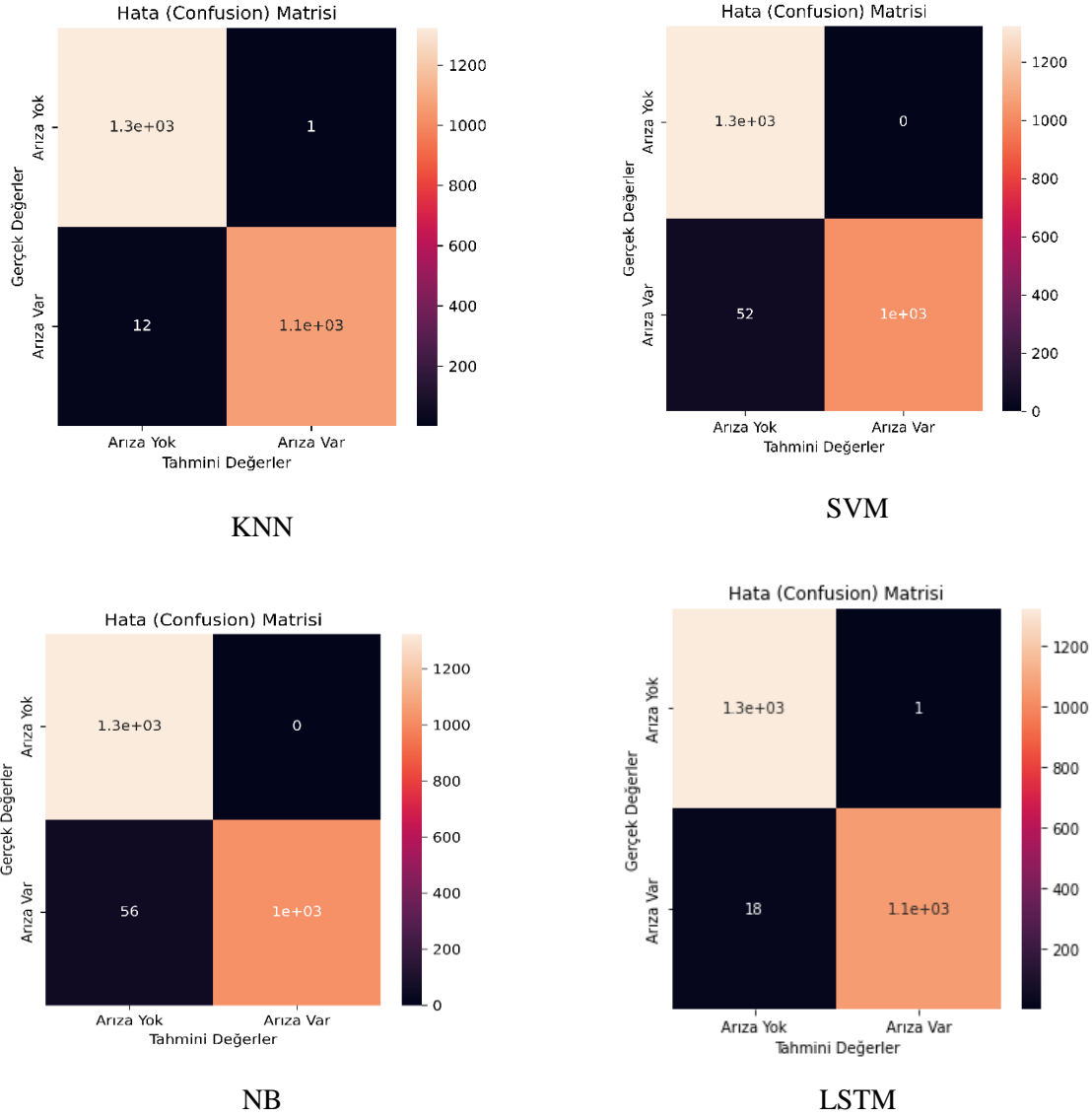

Çalışmada kullanılan KNN, SVM, NB ve LSTM yöntemlerinin elektrik arıza tespiti konusunda en iyi doğruluk performansının KNN ve LSTM ile sağlanabildiği görülmüştür. Elde edilen sonuçlar literatürde var olan benzer çalışmaların sonuçlarına yakın değerler elde edildiği görülmüştür.

### Sonuç ve Öneri

Bu çalışmada elektrik arızalarının makine öğrenmesi yöntemleri ile tespiti amaçlanmıştır. Çalışmada erişimine açık olan bir veri seti üzerinden farklı sınıflandırma yaklaşımları ile başarımlar değerlendirilmiştir. Çalışmada kullanılan KNN, SVM, NB ve LSTM yöntemlerinin elektrik arıza tespiti konusunda [97.7-- 99.4] aralıklarında bir başarı performansı sergiledikleri tespit edilmiştir. En iyi doğruluk performansının sırasıyla %99.4 ile KNN ve arkasından %99.2 ile LSTM yaklaşımları ile elde edildiği tespit edilmiştir. Ayrıca elektrik arıza tespiti konusunda kullanılan LSTM yönteminin, söz konusu alanda başarıyla kullanılabileceği tespit edilmiştir.

**Kaynakça**

- Janarthanam K, Kamalesh P, Basil T V, Judeson Antony Kovilpillai J (2022). "Electrical Faults-Detection and Classification using Machine Learning", Proceedings of the International Conference on Electronics and Renewable Systems (ICEARS 2022), IEEE Xplore Part Number: CFP22AV8-ART; ISBN: 978-1-6654-8425-1
- N. A. M. Leh, F. M. Zain, Z. Muhammad, S. A. Hamid and A. D. Rosli(2020). "Fault Detection Method Using ANN for Power Transmission Line," 2020 10th IEEE International Conference on Control System, Computing and Engineering (ICCSCE), Penang, Malaysia, 2020, pp. 79-84, doi: 10.1109/ICCSCE50387.2020.9204921.
- Ömer Faruk Ertuğrul, M. Bahattin Kurt (2011). Enerji İletim Hatlarında Modüler YSA ve ADD ile Hızlı Arıza Tespiti, e-Journal of New World Sciences Academy, 1A0128, 6, (1), 78-87.
- Abdul Malek Saidina Omar, Muhammad Khusairi Osman, Mohammad Nizam Ibrahim, Zakaria Hussain, Ahmad Farid Abidin (2020). Fault classification on transmission line using LSTM network, Indonesian Journal of Electrical Engineering and Computer Science, Vol. 20, No. 1, October 2020, pp. 231-238
- Jamil M., Sharma S.K., and Singh R(2015). Fault detection and classification in electrical power transmission system using artificial neural network, SpringerPlus 4:334, DOI 10.1186/s40064-015-1080-x
- Düzgün Akmaz (2022). "Güç Kalitesi Olaylarının Dalgacık Dönüşümü, K-En Yakın Komşu Algoritması ve Kazanç Oranı Özellik Seçme Yöntemi Kullanılarak Tanınması", International Journal of Innovative Engineering Applications, 6, 1(2022), 42-47.
- Sevgi AYHAN, Şenol ERDOĞMUŞ (2014). "Destek Vektör Makineleriyle Sınıflandırma Problemlerinin Çözümü İçin Çekirdek Fonksiyonu Seçimi", Eskişehir Osmangazi Üniversitesi İİBF Dergisi, Nisan 2014, 9(1), 175- 198.
- Wu X, Kumar V, Ross QJ, Ghosh J, Yang Q, Motoda H, Steinberg D (2008). Top 10 Algorithms in Data Mining. In Knowledge and Information Systems, 14 (1): 1-37.
- Cortes, C., ve Vapnik, V (1995). Support-vector networks. Machine Learning, 20(3):273-97.
- Emrah Aydemir, Murat Işık, Türker Tuncer (2021). "Türkçe Haber Metinlerinin Çok Terimli Naive Bayes Algoritması Kullanılarak Sınıflandırılması", Fırat Üniversitesi Müh. Bil. Dergisi, 33(2), 519-526, 2021. <https://doi.org/10.35234/fumbd.871986>
- Mustafa SU, Hidayet TAKCI (2023). "Naive Bayes ile Otistik Spektrum Bozukluğu Tanısı Koyma", Sırnak University Journal Of Sciences 3(2): 50-62-(2023)
- Jing Xia, Su Pan, Min Zhu, Guolong Cai, Molei Yan, Qun Su, Jing Yan, Gangmin Ning (2019). A Long Short-Term Memory Ensemble Approach for Improving the Outcome Prediction in Intensive Care Unit, Computational and Mathematical Methods in Medicine, Hindawi, Volume 2019, Article ID 8152713, <https://doi.org/10.1155/2019/8152713>
- J. P. Tan, A. L. A. Ramos, M. V. Abante, R. L. Tadeo and R. R. Lansigan (2022). "A Performance Review of Recurrent Neural Networks Long Short-Term Memory (LSTM)," 2022 3rd International Conference for Emerging Technology (INCET), Belgaum, India, 2022, pp. 1-5, doi: 10.1109/INCET54531.2022.9824567.



## HARMONICS STUDY IN ELECTRICAL GRID CONNECTED RENEWABLE ENERGY SYSTEMS

Yacine Djeghader<sup>1</sup>, Nora Daou<sup>2</sup>, and Omar Feddaoui<sup>3</sup>

<sup>1,3</sup> Department of Electrical Engineering, University of Mohamed-Cherif Messaadia ,Souk Ahras, ALGERIA ; BP 1553 Annaba Road 41000 Souk Ahra, Algeria.

<sup>2</sup>Faculty of Science and Technology, Hassan First University, Settat 26000, Morocco

<sup>1,3</sup>LEER Laboratory University of Mohamed-Cherif Messaadia ,Souk Ahras, ALGERIA;

### ABSTRACT

Photovoltaic energy is currently considered among the most used renewable energies. Given these advantages and rapid development, their integration and connection in the electrical system have become very important. This connection is usually made by the intervention of power electronic devices. The use of these devices degrades the quality of the energy and generates harmonics. In this paper we have presented the integration of a photovoltaic system in an electrical network (low voltage) in two scenarios, the first one without the polluting load (three-phase rectifier), and the second one with the presence of this non-linear load. In this study, we employ the Maximum Power Point Tracking (MPPT) controller to regulate the boost converter and Pulse-width modulation (PWM) control for the three-phase inverter, facilitating the connection. The simulation outcomes, excluding the non-linear load, demonstrate that the current waveforms in the photovoltaic (PV) system and the power grid closely resemble sin waves. The total harmonic distortion (THD) rates also conform to the specified standards. However, when the non-linear load is introduced, we observe a deformation in the current waveforms' quality, leading to elevated THD values surpassing the predefined standard

**Keywords:** Electrical Grid, Harmonic, Power system, Power Quality, MPPT, Renewable Energy Systems



### ANALYZING THE STABILITY OF THE CLOSED-LOOP SYSTEM IN AUTOMOBILE ADAPTIVE CRUISE CONTROL SYSTEMS

**Michael Okon Bassey**

Department of Mechatronics Engineering, Akwa Ibom State Polytechnic, Ikot Osurua, Ikot Ekpene, Nigeria.  
ORCID ID: 0000-0001-5433-7889

**Aniekan Essienubong Ikpe**

Department of Mechanical Engineering, Akwa Ibom State Polytechnic, Ikot Osurua, Ikot Ekpene, Nigeria.  
ORCID ID: 0000-0001-9069-9676.

**Victor Etok Udoh**

Department of Welding & Fabrication Engineering, Akwa Ibom State Polytechnic, Ikot Osurua, Ikot Ekpene, Nigeria.  
ORCID ID: 0000-0003-0864-9974

#### ABSTRACT

Surrounding the amount of traffic on the roads and the number of cars on the road, serious problems with traffic safety are emerging. Intelligent modes of transport (ITSs) and advanced driver assistance systems (ADASs) have been proposed globally in response to serious traffic accidents and environmental challenges. ADASs are technologies designed to increase active safety and provide drivers a better driving experience, however they have recently sparked worries from a variety of perspectives. This research study discusses the adaptive cruise control (ACC) technology, which lightens the driver's load. The ACC system manages the vehicle's acceleration and deceleration in order to maintain a certain speed or to avoid a collision. It primarily supports four driving modes on the road. In addition to managing the gap between cars, this research suggests more precise techniques for seeing the vehicle in front of you on radar while you're turning. This study further gives an overview of the adaptive cruise control system, its workings, and the benefits of including it in cars. Additionally, for the system to work at its best, it must be stable. To assess the stability of a close loop system, of which the cruise system is an example, the controller gain ( $K_1$ ,  $K_2$ ,  $K_3$ ) was calculated and then substituted into the characteristic equations. When simulated ACC cars with commercial availability are used, the traffic flow is very unstable and the bottleneck capacity falls with larger rates of market penetration, with some scenarios leading to a reduction in capacity of up to 35%. The research shows that string stability and inter-vehicle time gap have a significant impact on bottleneck capacity, whereas time gap is the only factor that affects downstream throughput. However, when  $K_1$ ,  $K_2$ , and  $K_3$  values were swapped into the characteristic equation, the stability of a closed loop system led to a negative real component.

**Keywords:** Adaptive Cruise Control, Close Loop System, Car Speed, Intelligent Transport System

#### 1. INTRODUCTION

With the amount of traffic on the roads and the number of cars on the road, serious problems with traffic safety are emerging. The deployment of Intelligent transportation systems (ITSs) and advanced driver assistance systems (ADASs) have been proposed globally in response to serious traffic accidents and environmental challenges. ADASs are systems designed to increase active safety and give drivers a better driving experience, however they have recently sparked worries from a variety of sources (Guo et al.,2020; He et al.,2017; Jiang et al.,2017). Adaptive cruise control, also known as speed control or autocruise, is a system that efficiently maintains the driver's desired set speed, without any intervention from the driver, by actuating and controlling the throttle accelerator pedal linkage. In other words, the system takes control of the car's throttle and maintains a steady speed limit desired by the driver. Over the past few years, a lot of research has been done on smart vehicles to address problems including pollution networks, pressure relief for drivers, crash avoidance, and more. In the modern automotive business, there are continuing initiatives to achieve autonomy (AVs). In recent years, cooperative adaptive cruise control (CACC) systems have garnered a lot of scientific interest. It is one

of the first connected and automated vehicle (CAV) applications designed for close-spaced cooperative vehicle following. The throughput of traffic can be significantly increased with a properly-designed CACC system, and fuel use and emissions can be decreased as well (Soufyane et al.,2020; Junejo et al.,2020; Gunter et al.,2020).

Preventing accidents is the main challenge when deploying autonomous technologies to assure safety (Singh & Bhattacharya,2020; Bharmal & Rashid, 2019). When activated, a vehicle's adaptive cruise control (ACC) system, according to Hunter [2], considers the traffic situation and steers the vehicle accordingly. In contrast to traditional cruise control systems, the ACC system also maintains a consistent distance between the automobile and the vehicle in front by adjusting to the flow of traffic on the road. As shown in the control loop block diagram in Figure 1, when the setting is programmed to run at a specific set point (desired speed), additional response (illustrated by the dotted and bold arrows in Figure 1) occurs sequentially to fully provide the necessary feedback needed to initiate the operation.

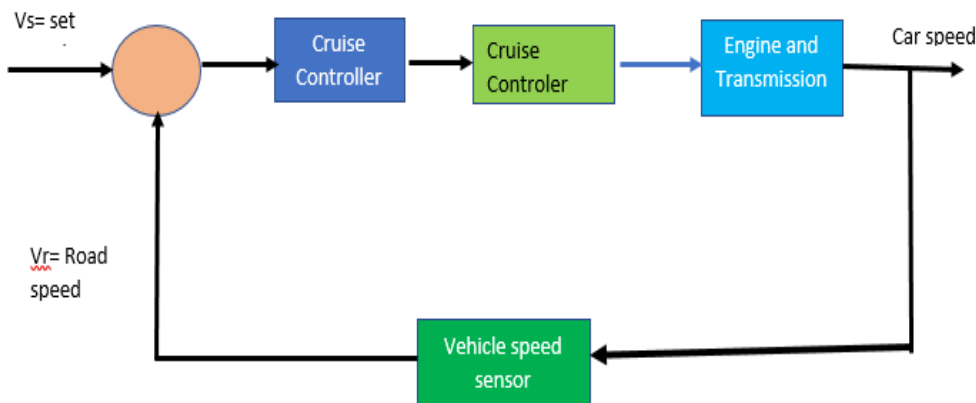

**Figure 1:** Block Diagram of a typical Car Cruise control Loop

A cable that is attached to an actuator during cruise control opens the throttle valve. By restricting the amount of air, the engine can intake, the throttle valve manages the engine's power and speed. Figure 2 depicts how two wires are attached to a pivot that rotates the throttle valve. The accelerator pedal and the actuator each produce one cable (Yi et al.,2015).

**Figure 2:** Cruise Control Acceleration





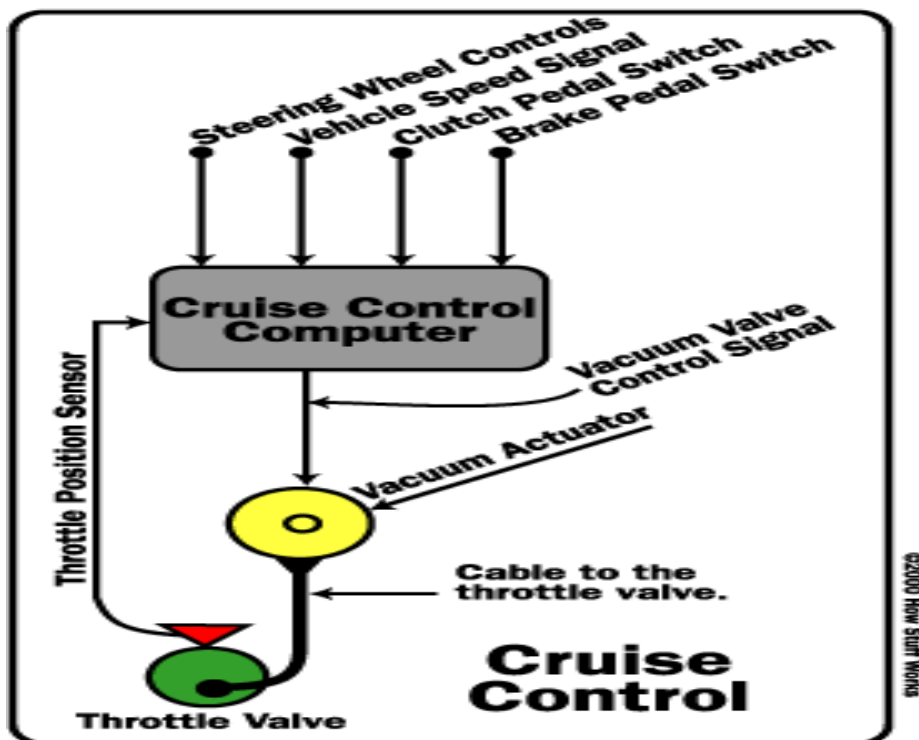

Figure 3: Controlling the cruise control

A little computer that is typically placed under the hood or beneath the dashboard serves as the brain of a cruise control system. It is connected to various sensors as well as the throttle control that was seen in the previous section. The inputs and outputs of a typical cruise control system are depicted in the diagram in figure 3. No matter how much weight is in the car or how steep the hill is that you are driving up, a strong cruise control system accelerates rapidly to the desired speed without overshooting and then maintains that pace with little deviation. Control system theory is frequently used to regulate a car's speed. The throttle position is adjusted by the cruise control system to manage the vehicle's speed; hence sensors are required to provide this information. In order to determine the appropriate speed and when to disengage, it must also keep an eye on the controls (Li et al.,2021; Makridis et al.,2021).

## 2. METHODOLOGY

The stability of a close loop system was calculated for K1, K2 and K3 and the results were substituted into the characteristic equation to generate real values in order to ascertain whether or not the ACC close loop system in this study is stable. This was done by taking into consideration the close loop transfer function of a typical ACC system as shown in Figure 4. With a step of 15% and a damping ratio of  $\xi = 0.7$ , this was done for peak overshoot.

## VII. 2.1 CONSIDERING CLOSED LOOP ACC SYSTEM

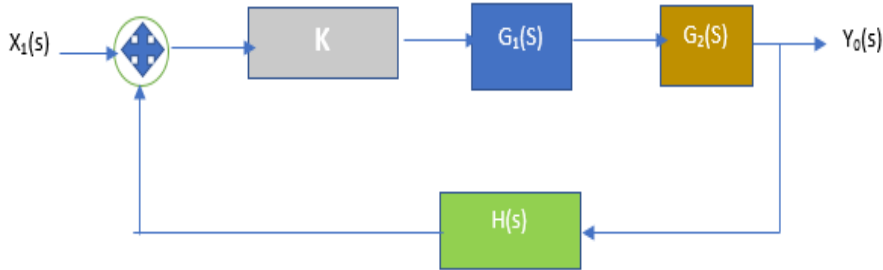

**Figure 4:** A schematic of Close Loop Transfer Function of a Typical ACC

From figure 3,

$G_1(S)$  = Transfer function of an actuator

$G_2 S$  = Transfer function of a plant

$H (S)$  = Transfer function of a measurement plant

$G_O(S)$  = Open loop transfer function

$G_{cl}$  = close loop transfer function

The transfer function of the closed loop is:

It is possible to combine the summing node, the  $G(s)$ , and the  $H(s)$  blocks into a single block, which would have the following transfer function:

$$G_{CL} = \frac{Y(s)}{Xs} = \frac{k G_1(s) G_2(s)}{1 + k G_1(s) G_2 H(S)} \tag{1}$$

Where  $G_1(s) = \frac{1}{s+12}$  and  $G_2(s) = \frac{10}{s+2}$ ,  $H(S)= 1$

Substituting the following values with the previous equation 1 we have

$$G_{cl} = \frac{10K}{s^2 + 14s + 24 + 10k} \tag{2}$$

## VIII. 2.2 CONSIDERATION OF THE DAMPING RATIO

If the damping ratio  $\xi = 0.7$

$$G(S) = \frac{K}{s^2 + 2\xi\omega_n s + \omega_n^2} \tag{3}$$

Thus, comparing equation 2 we have

$$2\xi\omega_n = 14 \tag{4}$$

$$\omega_n^2 = 24 + 10k \tag{5}$$

Substituting the damping value  $\xi = 0.7$  in 4

$$2(0.7)\omega_n = 14$$

$\omega_n = \frac{14}{1.4} = 10$  thus when  $\omega_n$  is substituted in 5 we have

$$10k = \omega_n^2 - 24 = 10^2 - 24 = 76$$

$$K_1 = 76/10 = 7.6$$

### IX. 2.3 CONSIDERING PEAK OVERSHOOT OF 15% STEP

$$\text{Power overshoot} = \exp\left(\frac{-\pi\xi}{1-\xi^2}\right) \tag{6}$$

$$0.15 = \exp\left(\frac{-\pi\xi}{1-\xi^2}\right) \text{ taking the logarithm of both sides}$$

$$\ln 0.15 = \exp\left(\frac{-\pi\xi}{1-\xi^2}\right) = \frac{-\pi\xi}{1-\xi^2}$$

$$\ln 0.15 \cdot 15 \left(\sqrt{1-\xi^2}\right) = -\pi\xi$$

$$3.5991(1-\xi^2) = (-\pi\xi)^2$$

$$\xi = \sqrt{0.26772} = 0.5169$$

substituting  $\xi = 0.5169$  in equation 4

$$\text{we have } 2(0.5169)\omega_n = 14$$

$$1.033\omega_n = 14$$

$$\omega_n = 14/1.033$$

$$\omega_n = 13.55$$

by substituting  $\omega_n = 13.55$  in (5)

$$\omega^2 = 24 + 10k$$

$$10k = \omega^2 - 24$$

$$K = 13.55^2 - 24/10$$

$$K_2 = 15.96$$

Then considering settling time of 4 seconds within 2% accuracy of the steady state value of the damping ratio 0.7 and employing the equation  $t_s = \frac{3}{\xi\omega_n}$

$$\text{We can evaluate for } \omega_n = 3/4 \times 0.7 = 1.071$$

Thus substituting the of  $\omega_n$  in equation (5) we have

$$\omega_n^2 = 24 + 10K$$

$$\text{Thus } K = 1.071^2 - 24/10$$

$$\text{There } K_3 = -2.285$$

### 3. ADAPTIVE CRUISE CONTROL SYSTEM CONFIGURATION

The Stop & Go (S&G) and Adaptive Cruise Control (ACC) systems can be seen as the first steps of such systems that try to aid the driver in highway or urban traffic. They have to regulate the speed and headway of the car in front of them. The system alone controls the speed and the safe distance from the car in front as the driver only has control over the vehicle's direction. The operating speed scale is what distinguishes the ACC and S&G systems:

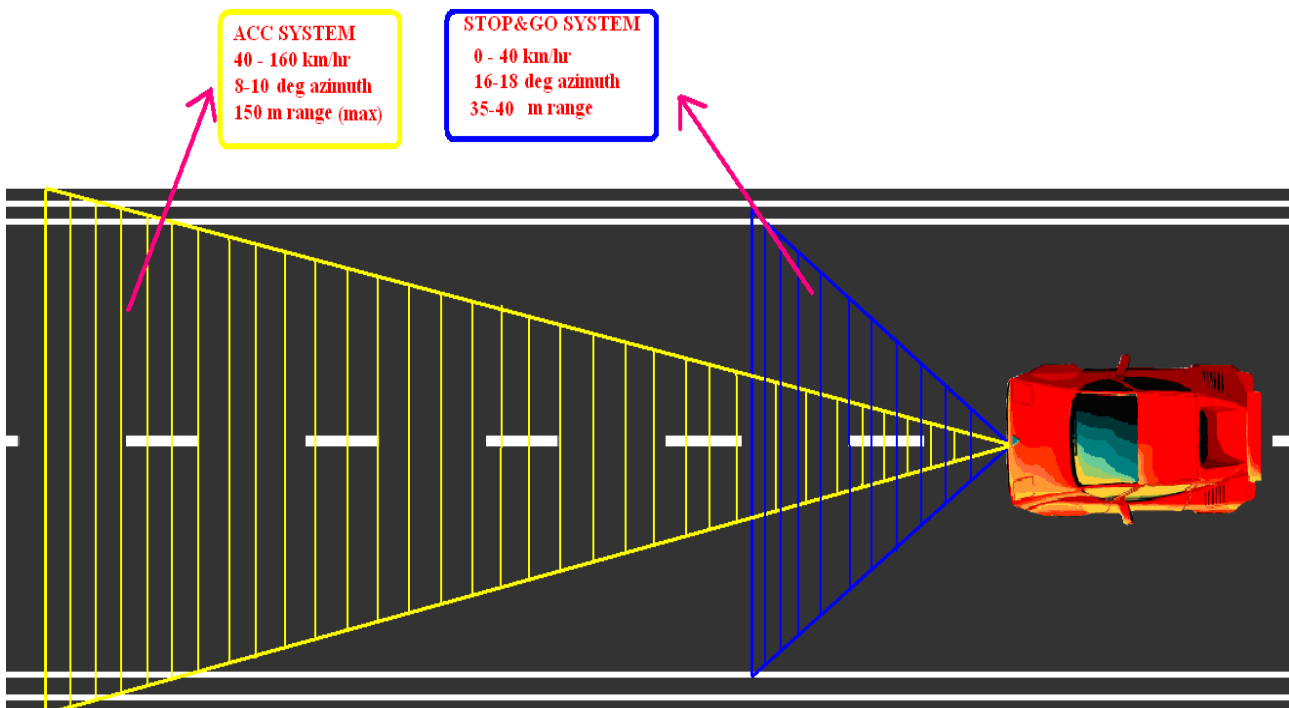

X. FIGURE 5: ADAPTIVE CRUISE CONTROL SYSTEMS PRINCIPALS

Although ACC is intended for highways with greater speeds, S&G is responsible for speeds below 40 km/h, including the halting operation and in more congested traffic (Patole et al.,2017; Hakobyan & Yang, 2019; Bilik et al.,2019). Figure 2 shows the principal of the S&G and ACC systems as well as the pace at which those systems operate: A forward-looking sensor is used by ACC and S&G systems to identify the target vehicle, and throttle and brake actuators are used to provide the necessary acceleration and deceleration during a subsequent operation. Their ability to function makes driving safer and more comfortable while also lightening the driver's workload. Thus, the functioning of these devices reduces driver fatigue and enables the driver to react more quickly in an emergency.

The ACC system should be able to carry out two distinct duties depending on the environment. If a lead vehicle is found, the ACC system should follow it while keeping a suitable relative distance. Like a traditional cruise control system, the ACC system should maintain the intended speed when no lead cars are detected in front of the host vehicle. It is crucial that not only do both modes function correctly and steadily, but that the transition between them is also seamless and secure.

**XI. 4. CONCEPT OF THE VIRTUAL LEAD VEHICLE SCHEME**

The ACC system need to be capable of operating in two modes: distance control and speed control. The distance between the lead and host cars, both desired and real, affects the modes. Creating two different controllers and switching between them is one method of putting these two modes into practice. However, this may result in a number of issues. A different approach is the virtual lead vehicle system, which eliminates the need to switch between the distance control algorithm and the speed control algorithm (Kim ,2009). The virtual lead vehicle approach simplifies the structure of the control system.

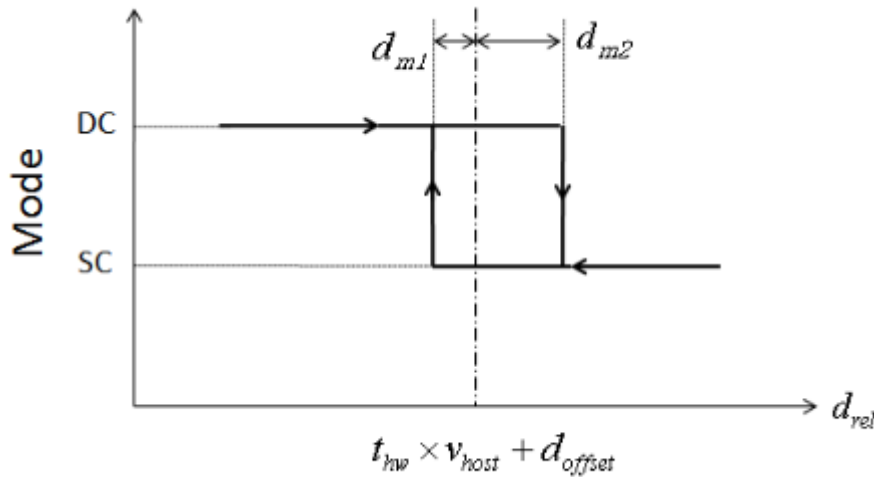

**Figure 6:** Mode switching logic

Thus, the mode decision can be inferred as follows; when the host vehicle follows a lead vehicle the desired distance is given by:

$$XII. \quad D_{DESIRED} = T_{HW} V_{HOST} + D_{OFFSET} \tag{8}$$

where

$d_{offset}$  = the safety distance to be maintained in the event of a complete stop

$v_{host}$  = the host vehicle's velocity

$t_{hw}$  = the time headway.

When the lead car abruptly stops and the host vehicle continues its speed, the time headway is the amount of time it will take for the two vehicles to crash. When the ACC system is engaged, the driver selects the required time headway. Using Figure 6, the following formula may be used to identify the correct mode:

$$Mode = \begin{cases} DC & d_{rel} \leq d_{desired} \\ SC & d_{rel} > d_{desired} \end{cases} \tag{9}$$

where

DC = Distance control

SC = Speed control,

$D_{rel}$  = relative distance to the lead vehicle.

However, if the distance between the lead and host vehicles is too near to the intended distance, using this technique may result in chattering in the algorithm. Marginal distances are introduced as: to stop chattering.

$$mode = \begin{cases} SC \rightarrow DC & d_{rel} - dm_1 \leq d_{desired} \\ DC \rightarrow SC & d_{rel} + dm_2 > d_{desired} \end{cases} \tag{10}$$

Thus,

$dm_1$  and  $dm_2$  = marginal distances.

As seen in Figure 6, this causes hysteresis in the mode switching.  $D_{rel}$  is limitless and the speed control mode is used if there is no lead vehicle.

5. Virtual Lead Vehicle Scheme and Control of the Virtual Lead Vehicle in Transient

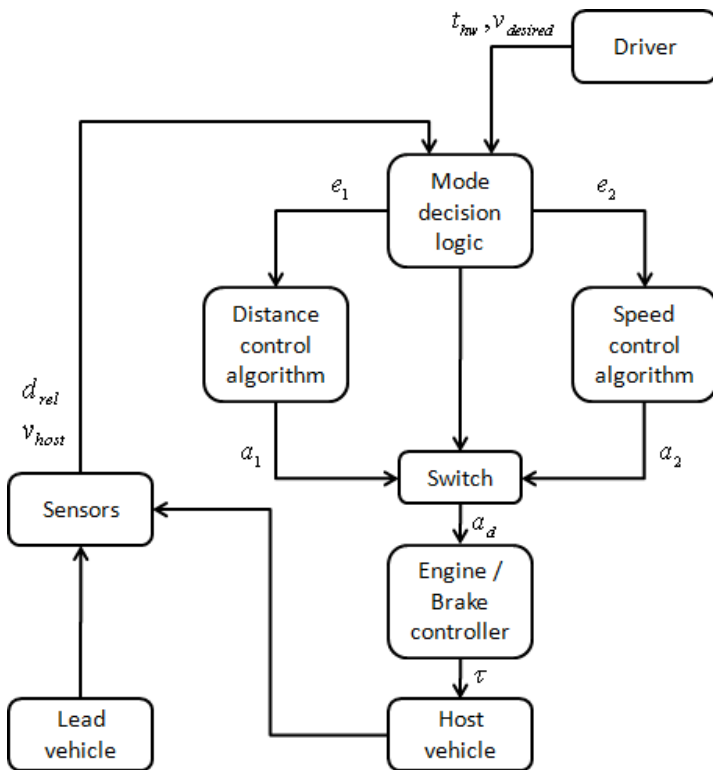

Figure 7: Block diagram of the mode switching scheme

The virtual lead vehicle scheme's conceptual drawing is shown in Figure 3.3. In the virtual lead vehicle system, the host vehicle uses a distance control algorithm to follow the virtual lead vehicle in the absence of the real lead vehicle. The location and velocity of the virtual lead vehicle are adjusted to match those of the real lead vehicle when a lead vehicle is identified within the appropriate relative distance and its speed is less than the desired speed.



Figure 8: Concept of the virtual lead vehicle scheme

The virtual lead vehicle technique prevents switching to the speed control algorithm by capping the velocity of the virtual lead vehicle at the appropriate speed when no lead vehicle is identified or if the speed of the lead vehicle is too high. In that situation, integrating the velocity updates the location of the virtual lead vehicle.

As a result, the virtual lead vehicle strategy does not use the speed control algorithm, and the total controller structure only includes one loop, the distance control algorithm, as shown in Figure 3.4.

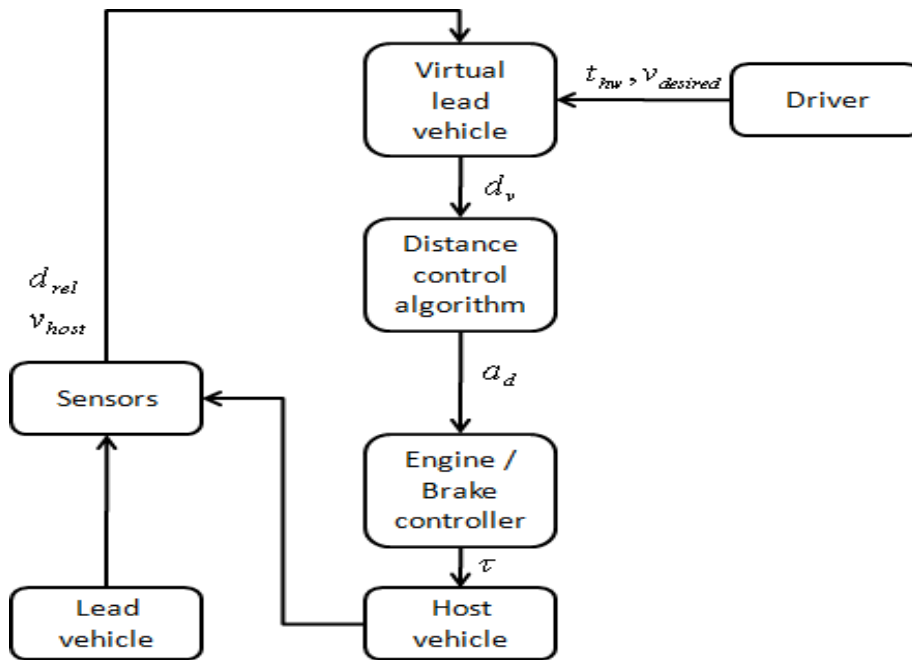

**Figure 9:** Block diagram of the virtual lead vehicle scheme

### XIII. 6. STABILITY

The most crucial component of all control systems is stability. Ineffective feedback controllers have the potential to turn stable systems unstable. When it comes to ACC systems, stability implies that the host vehicle's speed and the lead vehicle's distance from it converge to the required values. String stability should be accomplished for a platoon of vehicles in addition to the stability of a single vehicle. If not, it can become problematic if a platoon of cars all have the same ACC system installed. When the first vehicle in the platoon accelerates or decelerates, the distance errors along the vehicle stream rise if the feedback controller is not appropriately configured. The appropriate relative distance must be accurately calculated (Rajamani & Rajamani ,2012) or vehicle-to-vehicle communication is necessary to ensure string stability (Nair, 2013).

### XIV. 7. DISTANCE CONTROL & SPEED CONTROL

If the lead vehicle is travelling faster than the desired pace or cannot be detected by sensors, ACC systems, like conventional cruise control systems, should maintain the target speed set by the driver. Not only must the speed controller and distance controller function correctly and steadily, but also the transient performance must be stable. For instance, if a lead vehicle cuts out, the relative distance to the replacement lead vehicle may be quite large, causing the speed control to be engaged without the proper transient controller. In that situation, the host car accelerates needlessly, which is uncomfortable for the driver and wasteful of gasoline. (Rajamani & Rajamani ,2012).

### XV. 8. CONCLUSION

The development of the automotive intelligent cruise system provided some background on the study that was conducted to help fatigued drivers who were traveling long distances safely and accident-free. It has also provided a chance for research on driving assistance technologies. Systems like adaptive cruise control and intelligent cruise control allow drivers to specify a specific speed range so the vehicle may drive itself without hitting the vehicles in front of it, providing the cruise system's control loops are reliable. Maintaining constant driving speeds helps reduce the cost of fuel. The majority of drivers are not very good at keeping a set pace; instead, they gradually increase and decrease their speed as they go down the road, manually adjusting for the posted speed limit and any unusual road features like hills. Continuous acceleration and braking uses a lot more fuel than maintaining a constant speed. The coming of Artificial intelligence will definitely enhance the

deployment of ACC and other trends in the automobile industry in order to reduce road fatalities and ensure the robust safety of commuters.

#### XVI. REFERENCE

- Soufyane, B., Abdelhamid, R., & Smail, Z. (2020). Adaptation mechanism techniques for improving a model reference adaptive speed observer in wind energy conversion systems. *Electrical Engineering*, 102, 1621-1637.
- Junejo, A. K., Xu, W., Mu, C., Ismail, M. M., & Liu, Y. (2020). Adaptive speed control of PMSM drive system based a new sliding-mode reaching law. *IEEE Transactions on Power Electronics*, 35(11), 12110-12121.
- Gunter, G., Gloudemans, D., Stern, R. E., McQuade, S., Bhadani, R., Bunting, M., ... & Work, D. B. (2020). Are commercially implemented adaptive cruise control systems string stable?. *IEEE Transactions on Intelligent Transportation Systems*, 22(11), 6992-7003.
- Singh, B., & Bhattacharya, A. (2020). Review on Safety Problems with Adaptive Cruise Control System in Automobiles. *management*, 3, 4.
- Bharmal, M. A., & Rashid, M. H. (2019). Designing an Autonomous Cruise Control System using an A3 LIDAR. In 2019 2nd International Conference on Innovation in Engineering and Technology (ICIET) (pp. 1-6). IEEE.
- Van Arem, B., C. J. van Driel, and R. Visser(2006). The Impact of Cooperative Adaptive Cruise Control on Traffic-Flow Characteristics. *IEEE Transactions on Intelligent Transportation Systems*, Vol. 7, No. 4, pp. 429–436.
- Shladover, S., D. Su, and X. Lu(2012) Impacts of Cooperative Adaptive Cruise Control on Freeway Traffic Flow. *Transportation Research Record: Journal of the Transportation Research Board*, 2012. 2324: 63–70.
- Guo, L., Ge, P., Sun, D., & Qiao, Y. (2020). Adaptive cruise control based on model predictive control with constraints softening. *Applied Sciences*, 10(5), 1635.
- He, D., He, W., Song, X., & Guo, H. (2017). Predictive cruise control of vehicles with pre-planned acceleration/deceleration command. In 2017 29th Chinese Control And Decision Conference (CCDC) (pp. 7558-7563). IEEE.
- Jiang, Y., Deng, W., He, R., Yang, S., Wang, S., & Bian, N. (2017). Hierarchical framework for adaptive cruise control with model predictive control method (No. 2017-01-1963). SAE Technical Paper.
- Yi, S. G., Kang, C. M., Lee, S. H., & Chung, C. C. (2015). Vehicle trajectory prediction for adaptive cruise control. In 2015 IEEE Intelligent Vehicles Symposium (IV) (pp. 59-64). IEEE.
- Li, T., Chen, D., Zhou, H., Laval, J., & Xie, Y. (2021). Car-following behavior characteristics of adaptive cruise control vehicles based on empirical experiments. *Transportation research part B: methodological*, 147, 67-91.
- Makridis, M., Mattas, K., Anesiadou, A., & Ciuffo, B. (2021). OpenACC. An open database of car-following experiments to study the properties of commercial ACC systems. *Transportation research part C: emerging technologies*, 125, 103047.
- Patole, S. M., Torlak, M., Wang, D., & Ali, M. (2017). Automotive radars: A review of signal processing techniques. *IEEE Signal Processing Magazine*, 34(2), 22-35.
- Hakobyan, G., & Yang, B. (2019). High-performance automotive radar: A review of signal processing algorithms and modulation schemes. *IEEE Signal Processing Magazine*, 36(5), 32-44.
- Bilik, I., Longman, O., Villeval, S., & Tabrikian, J. (2019). The rise of radar for autonomous vehicles: Signal processing solutions and future research directions. *IEEE signal processing Magazine*, 36(5), 20-31.
- 20] S.G. Kim, M. Tomizuka, and K.H. Cheng. "Mode Switching and Smooth Motion Generation of the Adaptive Cruise Control System by a Virtual Lead Vehicle". In: *IFAC Symposium on Control in Transportation Systems* (2009).



Rajamani, R., & Rajamani, R. (2012). Longitudinal vehicle dynamics. *Vehicle dynamics and control*, 87-111.

Nair, G. N. (2013). A nonstochastic information theory for communication and state estimation. *IEEE Transactions on automatic control*, 58(6), 1497-1510.

Kim, S.G., Tomizuka, M. and Cheng, K.H. (2009). "Mode Switching and Smooth Motion Generation of the Adaptive Cruise Control System by a Virtual Lead Vehicle". In: *IFAC Symposium on Control in Transportation Systems*.



## NUMERICAL INVESTIGATION OF VARIOUS MOTHER-FIN LENGTHS FOR T-SHAPED FINS ON THE MELTING PROCESS

**İsmail DEMİRKIRAN**

Research Assistant, İzmir Institute of Technology (IZTECH), Faculty of Engineering, Department of Mechanical Engineering, İzmir-Türkiye, (Responsible Author) ORCID: 0000-0003-4620-5514

**Erdal ÇETKİN**

Prof. Dr., İzmir Institute of Technology (IZTECH), Faculty of Engineering, Department of Mechanical Engineering, İzmir-Türkiye, ORCID: 0000-0003-3686-0208

### ABSTRACT

There is a strong need to increase the share of renewables in energy generation plants in order to decrease electricity prices and for decarbonization. Coupling of renewable energy and energy storage techniques is a must in order to stabilize power networks and to close the gap between energy supply and demand by avoiding intermittent nature of renewable facilities like wind and solar plants. However, the employment of rare earth materials such as Li, Co, and Mn in electrochemical batteries or Pt catalysts in fuel cells makes it difficult to store electricity from large-scale renewable sources directly in an economical way. Thermal energy storage of Phase Change Materials (PCMs) is a crucial alternative due to their energy storage capacity associated with latent heat for storing renewable electricity or heat cheaper than batteries and hydrogen. However, minimizing the high-conductive material for heat transfer enhancement of PCMs, which suffer from low thermal conductivity, is desired. The current study aims to numerically investigate the effects of T-shaped fin structures on the PCM melting process for various mother-fin lengths and locations of fins on the tube. The melting process is modeled in ANSYS Fluent, which governs the enthalpy-porosity technique, and the performance of distinct fin lengths is compared for the 30 min. melting time. Erythritol and copper fins are used as PCM and thermal enhancers in the shell-and-tube storage tank, respectively. The results showed that variations on T-shaped fin length do not change the melting ratio when located at the bottom region, and liquid fraction values are around 23.6%. But, if the fins are attached to the top region, mother fins with different lengths may perform better or worse depending on the natural convection characteristics. T-shaped fins can increase melting performance without using more expensive conductive materials depending on the fin attachment location.

**Keywords:** T-shaped fin; Phase Change Material; Latent Heat Thermal Energy Storage; Computational Fluid Dynamics.



### PARAMETRIC OPTIMIZATION OF ND: YAG LASER DRILLING OPERATION ON BASALT-PTFE COATED GLASS WOVEN FIBRE HYBRID COMPOSITE FOR HOLE TAPER USING TEACHING LEARNING BASED OPTIMIZATION ALGORITHM

**Amiya Kumar Sahoo and Dhananjay R. Mishra**

Department of Mechanical Engineering, Jaypee University of Engineering and Technology, A-B Road, Raghoagarh, India

#### ABSTRACT

Composite materials are well known for engineering usage due to their directional properties, corrosion and fatigue resistance. It consists of fibres within a matrix material that performs better than metals and alloys and has a high strength-to-weight ratio. Conversely, composite materials are difficult to cut as the variation of material properties and the abrasive nature of the fibres leads to lower tool life in conventional machining operations along with conditions of fibre pull out of the matrix. Therefore, unconventional machining processes like laser drilling are more suitable than conventional ones. Laser drilling is a thermal process in which the composite material gets melted and burnt to produce holes. The holes produced by the laser drilling process are tapered depending on the fibre and matrix material distribution and the laser parameters. Hence in this article, Nd: YAG laser drilling operation on a newly developed hybrid composite material of basalt and PTFE-coated glass woven fibres is reported and followed by parametric optimization of the process for hole taper using a Teaching Learning-based optimization algorithm. The lamp current, pulse width, stand-off distance and compressed air pressures were considered as the laser drilling process parameters. The optimization of the laser drilling process yielded a parametric setting of 180 A of lamp current, 3 m-s of pulse width, 1 mm of stand-off distance and 12 kg/cm<sup>2</sup> of compressed air pressure with a predicted value of hole taper 0.017 degrees.

**Keywords:** Laser drilling; Hybrid-composite; Fibre-reinforced composite; Optimization; TLBO



## STUDY OF THERMAL BEHAVIOR OF LITHIUM-ION BATTERIES USING SOFTWARE

**Purushottam Kumar & BP Singh**

Department of Physics, Institute of Basic Science, Dr. Bhimrao Ambedkar University, Agra-282002 (U. P.) India

### ABSTRACT

Lithium-Ion Batteries (Li-ion) are the advance form of batteries recently utilized in various applications. Li-ion batteries are the preferred technology for hybrid and fully electric vehicles, power tools, and portable gadgets due to their unmatched combination of high energy and power density. In this battery the electrolyte acts as a conduit for the ion exchange that generates electricity. Batteries of all shapes and sizes are thought to be one of the best methods for storing energy; nonetheless, the environmental effects of widespread battery use continue to be a significant issue that needs further research. The high-energy materials and the organic components of a Li-ion battery are unstable at temperatures above 130–150 °C and are prone to produce greater heat. The battery temperature will rise further and the heat-releasing process will quicken if the created heat is not expelled. The main Li-ion battery components are presented and contrasted in this study, along with the accompanying battery management systems and methods for enhancing battery efficiency, capacity, and lifespan. The thermal runaway mechanism is discussed in this work, along with a number of thermal runaway mitigation strategies, such as separators, flame retardants, and safety vents.

**Keywords:** Battery efficiency, Li-ion batteries, Battery Management Systems, Electrode Materials, and Thermal Runaway



## THE IMPACT OF INCREASING FUEL PRICES ON FAMILY BUDGET IN INDONESIA

**GUSTHYTA PUTRI NABILA**

Faculty of Islamic economics and business, UIN K.H. Abdurrahman Wahid Pekalongan, Indonesia  
ORCID ID: <https://orcid.org/0009-0002-8417-2901>

**HENDRI HERMAWAN ADINUGRAHA**

Faculty of Islamic economics and business, UIN K.H. Abdurrahman Wahid Pekalongan, Indonesia  
ORCID ID: <http://ortid.org/0009-0003-5-488-8252>

### ABSTRACT

The increase in fuel oil (BBM) prices is a problem that often affects family budgets in Indonesia. This research aims to identify the impact of rising fuel prices on family budgets and their lifestyles. This research method involves surveys and analysis of household budget data from various families in various regions of Indonesia.

The research results show that the increase in fuel prices has a significant impact on the family budget. Higher fuel prices lead to increased transportation costs, which in turn reduces the amount of money available for other needs such as food, education and health. Families with lower incomes tend to be more affected by rising fuel prices, while families with higher incomes may have more leeway in dealing with rising transportation costs.

Apart from that, rising fuel prices can also affect family lifestyles. Some families may be forced to reduce their social or recreational activities to save money, while others may seek cheaper transportation alternatives. The impact of rising fuel prices can also stimulate behavioral changes such as using public transportation more frequently or switching to alternative fuel vehicles.

This research provides a better understanding of how rising fuel prices affect family budgets and their lifestyles in Indonesia. These results could be useful in designing better policies to protect low-income families from these adverse economic impacts

**Keywords:** Impact,Indonesia,Lifestyles,Survey,Education,and Health Policies



## ENVIRONMENTAL IMPACT ANALYSIS OF LITHIUM EXTRACTION

**Usman Aliyu Taliyawa, Hamma Ibrahim Siddi, Umar Zahradeen, Saidu Abdullahi Kwace**

Modibbo Adama University, Yola, Ne Nigeria

### ABSTRACT

Lithium is the lightest and least dense element at a temperature of 20°C, a very soft alkali metal that does not occur in elemental form in nature due to its high reactivity. Due to its crucial role in contemporary technology and its use in a number of different industries, including batteries, ceramics and glass, medicines, and lubricating greases, lithium is currently in high demand. Battery demand is predicted to increase as the UN works to reach net-zero greenhouse gas emissions, which can be accomplished by introducing electrically powered vehicles (EPV) and grid battery storage systems. Lithium is extracted from pegmatites, sedimentary rocks, and brines. Building a mine, removing the clay or ore, and isolating the metal through a convoluted process are required to extract lithium from pegmatites and sedimentary rocks. This process will have an impact on the environment because it frequently entails shifting thousands of acres of dirt and rock (known as overburden material), disrupting nearby land, and eradicating plant life. Extraction from brines, on the other hand, necessitates pumping the brine to the surface and then evaporating it to concentrate the lithium. The process necessitates a significant amount of fresh water, which is frequently obtained from wells, streams, or aquifers that are also used for agricultural or drinking water. As a result, fresh water is a vital resource in the dry regions where lithium deposits are located. Chemicals used in lithium production can pollute soil and water, endangering both the environment and human health. Lithium extraction and processing are energy-intensive processes that increase carbon emissions, especially in areas with fossil fuel-based energy sources. Sustainable mining techniques, resource recycling, policy and regulation, and community engagement will be used to address these issues.



### THE REVIEW OF INFRASTRUCTURE REQUIREMENTS FOR ELECTRIC AUTOMOTIVE

**MOHAMMED ALAA ALWAFIAE**

István Sályi Doctoral School of Mechanical Engineering Sciences, The University of Miskolc Miskolc,3500UTCA, Hungary

**BELA KOVACS**

István Sályi Doctoral School of Mechanical Engineering Sciences, The University of Miskolc Miskolc,3500UTCA, Hungary

#### ABSTRACT

The field of economics and business administration pertaining to electric cars encompasses a range of elements, such as market analysis, consumer behavior, supply chain management, business models, financing and investment, and infrastructure development. Among these elements, infrastructure development is of utmost importance for the growth and sustainability of the electric car industry. It involves the establishment of networks of charging stations, advancements in battery technology, and the integration of smart grid systems. These three components, which we will define and explore as the latest technology in this field evolves, play a critical role in ensuring the success of electric cars as a practical alternative to gasoline-powered vehicles. The availability of charging stations, advancements in battery technology, and the integration of smart grid systems contribute to increased convenience and practicality of electric cars, reduced ownership costs, and enhanced sustainability within the industry.

**Keywords-** Electric cars, Infrastructure development, Charging station networks, Advancements in battery technology, Sustainability.

#### Introduction

Infrastructure development plays a crucial role in the electric car ecosystem, enabling the widespread adoption and effective operation of electric vehicles (EVs). It encompasses several key components, including the establishment of charging station networks, advancements in battery technology, and the integration of smart grid systems.

#### 1. charging stations

It play a pivotal role in supporting the usability and practicality of electric cars by providing a reliable and convenient means of recharging. They are an essential component of the infrastructure necessary for the widespread adoption and success of electric vehicles because facilities or points where electric vehicles (EVs) can be charged.

#### 1.1 Types of Charging Stations:

Charging stations come in different forms and charging capabilities, catering to various needs and charging speeds. Here are some common types:

##### 1.1.1 Level 1 Charging:

This is the simplest and slowest form of charging, typically using a standard household electrical outlet (120 volts AC). Level 1 chargers are portable and come with most electric vehicles. However, they provide the slowest charging rate and are best suited for overnight charging at home.

### 1.1.2 Level 2 Charging:

Level 2 chargers operate at higher power levels (240 volts AC) and provide faster charging compared to Level 1. They require specialized charging equipment and are commonly installed in public locations, workplaces, and residential areas. Level 2 chargers can fully charge an electric vehicle in a few hours, depending on the battery capacity.

### 1.1.3 DC Fast Charging:

DC fast chargers, also known as Level 3 chargers, offer the fastest charging speeds for electric cars. They operate at much higher power levels (typically 400 volts or higher) and can charge an EV to 80% or more in around 30 minutes. DC fast chargers are commonly found along highways, commercial areas, and EV charging networks.

## 1.2 Charging Station Components:

### 1.2.1 Charging Unit:

The charging unit is the main component of a charging station. It contains the necessary hardware and software to provide electricity to the electric vehicle's battery.

### 1.2.2 Connector:

We have several type :

- ❖ **J1772 Connector:** The J1772 connector is the standard connector for Level 1 and Level 2 charging in North America. It features a plug and socket design, allowing for the safe and secure connection between the charging station and the electric vehicle.
- ❖ **CCS (Combined Charging System) Connector:** CCS connectors are used for DC fast charging and are widely adopted in Europe and North America. They combine the AC charging pins of the J1772 connector with additional DC charging pins for high-speed charging.
- ❖ **CHAdeMO Connector:** CHAdeMO connectors are primarily used for DC fast charging and are common in Asian markets. They have a distinct plug design and enable high-power charging for compatible electric vehicles.
- ❖ **Tesla Supercharger Connector:** Tesla vehicles use their proprietary connector for high-speed charging at Tesla Supercharger stations. Tesla vehicles also come with an adapter that allows them to be charged using other charging connectors.

### 1.2.3 Display and Payment System:

Charging stations often feature a display panel that provides information such as charging status, energy consumption, and sometimes payment options. Payment systems can include credit card readers, mobile payment apps, or RFID cards.

### 1.2.4 Networking and Communication:

Many charging stations are connected to a network, allowing for remote monitoring, maintenance, and payment processing. Networked charging stations provide real-time information on availability, usage, and charging rates.



### 2. Examples of smart grid systems being integrated with electric car infrastructure

Integrating smart grid systems with electric car infrastructure is an important step towards optimizing the charging process, managing energy flow, and enhancing the overall efficiency of the electric grid. Here are some examples of how smart grid systems can be integrated with electric car infrastructure:

1. **Demand Response Programs:** Smart grid systems can enable demand response programs, where charging stations can adjust their charging rates or schedules based on the grid's supply and demand conditions. This allows for better load management and can help prevent grid congestion during peak periods.
2. **Vehicle-to-Grid (V2G) Technology:** V2G technology enables bidirectional energy flow between electric vehicles and the grid. Electric vehicles can not only draw electricity from the grid but also send excess energy back to the grid when needed. This capability can help balance the grid, support renewable energy integration, and provide grid services such as frequency regulation.
3. **Smart Charging Management:** Smart grid systems can facilitate intelligent charging management, allowing for optimized and coordinated charging of electric vehicles. Charging stations can communicate with the grid to determine the best charging times, considering factors such as electricity prices, grid load, and renewable energy availability.
4. **Grid-Friendly Charging Infrastructure:** Smart grid systems can enable the development of grid-friendly charging infrastructure. This includes features such as load balancing, where charging stations distribute the load evenly across the grid to prevent localized overloads. It can also include the capability to communicate with the grid to receive real-time grid status updates and adjust charging accordingly.
5. **Grid Integration with Renewable Energy Sources:** Smart grid systems can integrate electric vehicle charging with renewable energy sources. Charging stations can prioritize charging when renewable energy generation is high, promoting clean energy utilization and reducing the reliance on fossil fuel-based power generation.

### 3. Advancements in battery technology:

The potential to significantly improve the efficiency and range of electric vehicles (EVs) in several ways:

1. **Increased Energy Density:** Battery technology advancements can lead to higher energy density, allowing for more energy storage within the same physical size or weight of the battery pack. This means that EVs can store more energy, resulting in longer driving ranges without the need for frequent recharging.
2. **Improved Energy Efficiency:** Enhanced battery technology can improve the overall energy efficiency of EVs. This includes reducing energy losses during charging and discharging processes, minimizing internal resistance within the battery cells, and optimizing the battery management system. By improving efficiency, more energy can be effectively used to propel the vehicle, resulting in longer ranges for the same amount of stored energy.
3. **Rapid Charging Capability:** Advancements in battery technology can enable faster charging times. This includes the development of fast-charging technologies and the ability to handle higher charging currents without negatively impacting battery life. Rapid charging capabilities reduce the time required to recharge an EV, making them more convenient and comparable to refueling a gasoline-powered vehicle.
4. **Longer Battery Lifespan:** Battery technology advancements can improve the durability and longevity of EV batteries. This includes advancements in electrode materials, cell chemistry, and thermal management systems. Longer battery lifespan reduces the need for frequent battery replacements, lowering the overall cost of ownership and improving the practicality of EVs.
5. **Enhanced Thermal Management:** Efficient thermal management systems for batteries can prevent overheating and thermal degradation, ensuring optimal battery performance and longevity. Improved cooling and heating mechanisms can maintain the battery within an optimal temperature range, maximizing its efficiency and extending its lifespan.
6. **Solid-State Batteries:** The development of solid-state batteries, which replace the liquid electrolyte with a solid-state electrolyte, shows promise for higher energy density, improved safety, and faster charging times.

Solid-state batteries have the potential to revolutionize EVs by addressing current limitations and unlocking even greater efficiency and range.

### Conclusion

The field of economics and business administration related to electric cars encompasses various elements, including market analysis, consumer behavior, supply chain management, business models, financing and investment, and infrastructure development. Infrastructure development, particularly the establishment of charging station networks, advancements in battery technology, and integration of smart grid systems, is crucial for the growth and sustainability of the electric car industry.

The availability of charging stations ensures that electric car owners have convenient access to charging facilities, addressing concerns about range anxiety and promoting widespread adoption. Advancements in battery technology improve the efficiency, range, and charging capabilities of electric vehicles, making them more practical and comparable to traditional gasoline-powered cars. Integration of smart grid systems allows for intelligent management of energy flow and optimization of charging processes, enhancing the overall efficiency and sustainability of the electric car ecosystem.

By focusing on these three components, the electric car industry can achieve increased convenience, reduced ownership costs, and improved sustainability. Continued research and technological advancements will undoubtedly shape the future of electric cars, making them a viable and attractive alternative to conventional vehicles.

### References :

- [1] S. Hadley and A. Tsvetkova, "Potential impacts of plug-in hybrid electric vehicles on regional power generation," Oak Ridge National Laboratory, Tech. Rep., 2008.
- [2] G. A. Putrus et al., "Impact of electric vehicles on power distribution networks", Vehicle Power and Propulsion Conference, 2009. VPPC'09. IEEE. IEEE, 2009.
- [3] E. Akhavan-Rezai et al. "Uncoordinated charging impacts of electric vehicles on electric distribution grids: Normal and fast charging comparison", Power and Energy Society General Meeting, 2012 IEEE. IEEE, 2012.
- [4] C. R. Green II, L. Wang, and M. Alam, "The impact of plug-in hybrid electric vehicles on distribution networks: A review and outlook", Renewable and Sustainable Energy Reviews 15.1 (2011): 544-553.
- [5] M. Kintner-Meyer et al. "Impact Assessment of Plug-in Hybrid Vehicles on the US Power Grid." The 25th World Battery, Hybrid and Fuel Cell Electric Vehicle Symposium & Exhibition, Shenzhen, China. 2010.
- [6] K. Clement-Nyns, E. Haesen, and J. Driesen, "The impact of charging plug-in hybrid electric vehicles on a residential distribution grid." Power Systems, IEEE Transactions on 25.1 (2010): 371-380.
- [7] A. Masoum, A. Abu-Siada, and S. Islam, "Impact of uncoordinated and coordinated charging of plug-in electric vehicles on substation transformer in smart grid with charging stations", Innovative Smart Grid Technologies Asia (ISGT), 2011 IEEE PES, Nov. 13-16, 2011.  
132.
- [8] J. Liu, "Electric vehicle charging infrastructure assignment and power grid impacts assessment in Beijing", Energy Policy, Vol. 51, Dec. 2012, p544-p557.
- [9] G. Mauri, P. Gramatica, E. Frasciolo, and S. Fratti, "Recharging of EV in a typical Italian urban area: Evaluation of the hosting capacity", 2011 IEEE PowerTech, Trondheim, Jun. 19-23, 2011.

- [10] Y. He, B. Venkatesh, and L. Guan, "Optimal scheduling for charging and discharging of electric vehicles," IEEE Trans. Smart Grid, vol. 3, no. 3, Sep. 2012.
- [11] A. Shepelev, C. Chung, C. Chu, R. Gadh, "Mesh Network Design for Smart Charging Infrastructure and Electric Vehicle Remote Monitoring ", International Conference on ICT Convergence 2013, Jeju, Korea, Oct. 14-16, 2013.

**KAMPÜS BİNALARI VE ULAŞIMI İÇİN ENERJİ PLANLAMA VE OPTİMİZASYON  
MODELLEME**

**ENERGY PLANNING AND OPTIMIZATION MODELING FOR CAMPUS BUILDINGS AND  
TRANSPORTATION**

**Dr. Öğr. Üyesi Saltuk Buğra SELÇUKLU**

Erciyes Üniversitesi, Mühendislik Fakültesi, Enerji Sistemleri Mühendisliği Bölümü, Kayseri, Türkiye  
Enerji Dönüşümleri Araştırma ve Uygulama Merkezi, Erciyes Üniversitesi, Kayseri, Türkiye.  
ORCID ID: <https://orcid.org/0000-0002-9295-3866>

**Atabek MOVLYANOV**

Erciyes Üniversitesi, Fen Bilimler Enstitüsü, Enerji Sistemleri Mühendisliği ABD, Kayseri, Türkiye

## ÖZET

Enerji tüketimi ve iklim değişikliği sorunlarının artmasına çözüm olarak günümüzde enerji verimliliğini teşvik etmek, fosil enerji tüketimini azaltmak ve yenilenebilir enerji kaynaklarını kullanarak çevreye duyarlı enerji sistemleri kurmak en önemli unsurların biridir. Üniversiteler; büyük boyutları, nüfusları ve gerçekleştirdikleri pek çok iş ve eylemleriyle küçük birer şehir gibidir ve çeşitli birimlerinden hizmet alan kişiler de sayıya dâhil edildiğinde, üniversitelerin bulunduğu kente sağladığı yararların yanı sıra hem doğal çevreye hem de sosyal çevreye doğrudan ve dolaylı olumsuz etkileri bulunmaktadır. Buradan hareketle bu çalışmada, literatürdeki verimlilik optimizasyon çalışmaları incelenerek kampüs binaları ve ulaşımı için kapsamlı bir enerji planlama ve optimizasyon modeli kurulmuştur. Model, karışık tamsayı doğrusal olmayan programlama (MINLP) modelidir ve kesin optimizasyon sağlayan çözümlerle GAMS yazılımında ve optimumluğu garanti etmeyen ama hızlı çözüm sağlayan ve birer sezgisel algoritma olan *Pareto Uncertain Genetic Algorithm* (PUGA) ve *Artificial Bee Colony* (ABC) algoritmalarında çözdürülmüştür. Erciyes Üniversitesi örneğinde veri toplanarak araştırmanın ilk kısmı tamamlanmıştır.

**Anahtar Kelimeler:** Enerji planlama, Optimizasyon, Enerji verimliliği

## 1. GİRİŞ

Üniversiteler, geçmişten bugüne sosyal, ekonomik ve politik yaşamdaki değişimlerde önemli role sahip olmuştur. Ulusal ve küresel boyuttaki bu önemli konuları, üniversiteleri sürdürülebilir gelişmeyi farklı ölçeklerde ve tüm boyutları ile başarmada anahtar kuruluşlardan biri yapmaktadır. Sürdürülebilir üniversite kampüsleri tasarlamak, kapsamlı ve uzun vadeli bir süreç yönetimini gerektirmektedir. Bu süreçte, yeşil/sürdürülebilir üniversite kampüslerine yönelik kriterleri oluşturmak, altyapısal, yönetsel ve işletmeye dair düşünmeyi gerektiren en önemli birleşenlerden biridir. Bu anlayışla, tüm dünyada, çevreye duyarlı, enerji etkin yöntemleri kullanan, üniversite personeli ve öğrencilerinin yanı sıra bulunduğu şehre toplumsal ve ekonomik boyutta kalkınma sağlamayı amaçlayan sürdürülebilir üniversite kampüsü tasarımları ve uygulamaları yaygınlaşmalıdır. Üniversitelerde enerjinin verimli kullanılması ve YEK'ten faydalanılması ile hem enerji maliyetlerinin üniversite bütçesi üzerindeki yükü hafifletilebilecek, hem sürdürülebilir üniversite kriterleri için önemli bir adım atılacak, hem de üniversite kampüsleri daha çevreci şehirler için model olacaktır. Bu çalışmada amaç, Paris İklim Anlaşması'nı onaylayan ve Avrupa Birliği (AB) ile Yeşil Mutabakat sürecine dâhil olan Türkiye'nin yeşil dönüşüm adımlarını destekleyici nitelikte üniversite kampüsleri için modüler ve bütünsel enerji planlama ve optimizasyon modeli geliştirmektir.

## 2. LİTERTÜR TARAMASI

Birincil enerji tüketiminin artması ve iklim değişikliği, 21. yüzyılda karşılaştığımız en büyük zorluklar arasındadır. Birçok ülkede, hükümetlerin enerji verimliliğini (EV) teşvik ederek birincil enerji tüketimini

azaltmayı ve yenilenebilir enerji kaynaklarını (YEK) kullanmayı amaçlayan politikaları vardır [1]. Ülkemizde, son yıllarda artan nüfus ve sanayi faaliyetleri ile yükselen enerji talebimiz ve mevcut enerji kaynaklarımızın sınırlı oluşu, EV ve YEK imkânlarından faydalanılmasına ilişkin çalışmaları zorunlu hale getirmiştir. Üniversiteler; büyük boyutları, nüfusları ve gerçekleştirdikleri pek çok iş ve eylemleriyle küçük birer şehir gibidir ve çeşitli birimlerinden hizmet alan kişiler de sayıya dâhil edildiğinde, üniversitelerin bulunduğu kente sağladığı yararların yanı sıra hem doğal çevreye hem de sosyal çevreye doğrudan ve dolaylı olumsuz etkileri bulunmaktadır [2, 3]. Üniversiteler, geçmişten bugüne sosyal, ekonomik ve politik yaşamdaki değişimlerde önemli role sahip olmuştur. Ulusal ve küresel boyuttaki bu önemli konuları, üniversiteleri, sürdürülebilir gelişmeyi farklı ölçeklerde ve tüm boyutları ile başarmada anahtar kuruluşlardan biri yapmaktadır. Sürdürülebilir üniversite kampüsleri tasarlamak, kapsamlı ve uzun vadeli bir süreç yönetimini gerektirmektedir. Bu süreçte, yeşil/sürdürülebilir üniversite kampüslerine yönelik kriterleri oluşturmak, altyapısal, yönetsel ve işletmeye dair düşünmeyi gerektiren en önemli birleşenlerden biridir. Bu anlayışla, tüm dünyada, çevreye duyarlı, enerji etkin yöntemleri kullanan, üniversite personeli ve öğrencilerinin yanı sıra bulunduğu şehre toplumsal ve ekonomik boyutta kalkınma sağlamayı amaçlayan sürdürülebilir üniversite kampüsü tasarımları ve uygulamaları yaygınlaşmalıdır.

Üniversiteler gerek çalışanları gerekse öğrencileriyle oldukça kalabalık bir nüfusa ve binalar gibi enerji tüketen yapısal alanlara sahiptirler. Eğitim-öğretim faaliyetlerinin gerçekleştirildiği binalarda tükenebilir kaynak kullanımına alternatif üretmek, harcanan enerjinin ve malzemenin daha verimli bir şekilde kullanılmasını teşvik etmek, her türlü israfın önüne geçmek ve çevre dostu bina tasarımları gerçekleştirmek önem taşımaktadır [3]. Artan enerji maliyetleri ve çevresel endişeler, binalarda enerjinin verimli kullanımını zorunlu kılmıştır. Yapı sektöründe enerji tasarrufu sağlamak amacıyla yüksek enerji tüketimi olan üniversiteler odak haline gelmiştir. Ölçülen ve hesaplanan sonuçlar üniversitelerin yüksek enerji verimliliği potansiyeli olduğunu gösterir [3, 4]. Eğitim binaları için, ısıtma soğutma ve havalandırma ekipmanı ve aydınlatma sistemine odaklanan enerji verimliliği önlemleri, enerji tasarrufu ve verimliliği ve çevresel faydalar açısından büyük potansiyele sahiptir [4-9]. İncelenen çalışmalarda, bina kabuklarının yalıtılması, ısı merkezine kojenerasyon sisteminin kurulması, aydınlatma sistemlerinin verimlendirilmesi, PV kurulumuyla birlikte çatı güçlendirme ve yalıtımı, pencere değişimi ve renkli pencere kullanımı, ısıtma sistemlerinde biyokütle veya ısı pompaları kullanılması, klima ayarlarının optimizasyonu, ısı geri kazanım sistemlerinin kurulumu, HVAC için düzenlemeler ve LED lambalarının otomatik kontrolü gibi enerjinin verimli kullanılabilmesi için çeşitli çalışmalarda optimizasyon modelleri kullanılmıştır [1, 5, 6, 8, 10-15]. Literatürdeki çalışmalardan görüldüğü üzere, kampüs binalarında EV ve YEK için en uygun uygulamaların belirlenmesinde, enerji tüketimi, emisyon değerleri ve ilk yatırım maliyeti gibi amaç fonksiyonları doğrultusunda çok amaçlı optimizasyon modellerinden faydalanmak karar vericiler için çok faydalı olacaktır. Yapı kabuğu, ısıtma, soğutma ve sıcak su sağlayan enerji sistemleri, elektrikli cihazlar, aydınlatma sistemleri ve YEK uygulamaları karar değişkenleri olarak seçilebilir.

Binalardan sonra kampüste önemli enerji tüketim ve zararlı gaz salınım sebeplerinden biri de ulaşımdır. Malezya Teknoloji Üniversitesinde yapılan bir çalışmada [16], elektrik enerjisi tüketimi yaklaşık %74 ile kampüsün karbon emisyonunun en büyük bileşenini oluştururken, yıllık karbon emisyonunun %26'sını oluşturan ikinci CO<sub>2</sub> emisyonu ve enerji tüketimi bileşeni ulaşımdır. Ulaşım emisyonunun %75'ini personel ve özel araç kullanan öğrencilerin yakıt tüketimi oluşturmaktadır. ABD'nin orta batısındaki büyük bir kampüste yapılan bir çalışmada, kampüse insanların %51'inin tek başına araba ile gittiğini, %18'inin toplu taşıma kullandığını, %8'inin yürüdüğünü, %10'unun bisiklete bindiğini, %9'unun araba paylaşımı yaptığı, %1'inin motosiklet kullandığını ve %3'ünün diğer kategorisine düştüğünü ortaya koyar [17]. Nanjing Teknoloji Üniversitesi kampüsünde gerçekleştirilen bir çalışmada [18], bisiklet park noktalarının yerleşim ve planlaması için bir optimizasyon modeli geliştirilmiştir. Optimizasyondan sonra kullanıcıların seyahat süresi %6 oranında azaltılmış ve paylaşılan bisiklet park yeri sayısı 51'den 35'e düşürülmüştür. Böylece bisiklet park yerlerinin işletme ve bakım maliyetleri etkili bir şekilde azaltılmıştır. Balıkesir Üniversitesi Kampüsünde yapılan bir çalışmada da [19] kampüs içi öğrenci ve personel ulaşım hareketliliğine kolaylık sağlayacak elektrik bisiklet paylaşım sistemi önerilmiştir. Elektrikli bisikletlerin şarj ihtiyaçlarını PV sistemle karşılamak için bir şarj istasyon tasarımı da yapılmıştır. Çalışmada, elektrikli bisiklet sayısı belirlenmiş, enerjinin sağlanması için gerekli olan PV panel sayısı ile batarya sayısı hesaplanmıştır. Bu sistemin önemli avantajlarından biri de PV panellerde üretilen ihtiyaç fazlası enerjinin şebekeye aktarılabilmesi ve bu sayede katma değer sağlanabilecek

olmasıdır. Zimmer vd. ise [20] bir üniversite kampüsünde toplu taşımayı optimize etmek için veri analitiği yöntemini kullanmaktadır. Yolcu ve araç bekleme sürelerini azaltarak hem yakıt maliyetlerinde azalma hem de yolcu memnuniyetinde artış hedeflenmiş ve sonuçta %2.7'lik yakıt tasarrufu sağlanmıştır. ODTÜ kampüsünde yapılan bir çalışmada da [21] özel araç sayılarındaki potansiyel azalma, toplu taşıma potansiyel artışı ve bunlara karşılık gelen karbon emisyonları hesaplanmış ve sonucun karbon ayak izine net etkisi gösterilmiştir. Benzer bir yöntemle, Bustillos vd. [22], kampüs trafiği ve park planlamasını simülasyon tabanlı trafik analizi ile incelemiştir. Çalışmanın amacı kampüs içi yolculuğun merkez-varış tahmini ve park yeri seçim kalibrasyonudur. Merkez-varış tahmini yapılırken tek amaçlı doğrusal bir optimizasyon modelinden faydalanılmıştır. Nematchoua vd.'ne [23] göre ise bir şehir veya bölgedeki elektrikli araçların sayısını artırmak, enerji tüketimi ve emisyonları azaltmanın en etkili yollarından biridir. Nitekim, ABD'de bir kampüste, kampüs içi gezen araçlar elektrikli hizmet araçlarına dönüştürülerek karbon ayak izi kısmen azaltmıştır [24].

### 3. YÖNTEM

Bu çalışmada enerji planlama ve optimizasyon modeli kurulumu ve bu modeli modüler ve bütünlük programlama ile bir yazılım paketi hazırlama yöntemleri araştırılmıştır. Bu amaç doğrultusunda aşağıdaki maddeler halinde özetlenebilir:

- Binalarda enerji verimliliği optimizasyon modeli kurmak,
- Ulaşımında enerji verimliliği optimizasyon modeli kurmak,
- Binalar ve otoparklar için yenilenebilir enerji planlama ve optimizasyon modeli kurmak,
- Kampüs içi enerji depolama için planlama ve optimizasyon modeli kurmak,
- Kurulan modelleri bütünlük çalışabilir hale getirmek.

Şekil 1'de görüldüğü üzere model çeşitli katmanlardan oluşmaktadır. Kullanıcılar, bir web ara yüzü vasıtasıyla veri girişi, haritalama ve genel optimizasyon ayarları yapabilecektir. Kullanıcının değişik dosya formatlarında yaptığı girişler bir veri tabanında depolanacaktır. Tüm veriler, optimizasyon ara yüzüne gönderilmeden önce veri işleme için Python programında hazırlanacak kod ile işlenecek, tek bir formata dönüştürülecek ve optimizasyon modellerinde kullanılmak üzere hazır hale getirilecektir. Modelin kurulma aşamasında 3 farklı optimizasyon yazılımı kullanılacaktır. Bir karışık tamsayılı doğrusal olmayan programlama (MINLP) modeli, kesin optimizasyon sağlayan GAMS yazılımında ve optimumluğu garanti etmeyen ama hızlı çözüm sağlayan ve birer sezgisel algoritma olan *Pareto Uncertain Genetic Algorithm* (PUGA) ve *Artificial Bee Colony* (ABC) algoritmalarında çözdürülecektir. PUGA ve ABC'nin sonuçları GAMS sonuçları ile karşılaştırılacak, gerektiğinde iyileştirmeler yapılacak ve performansı en iyi olan nihai modelde kullanılacaktır.

Şekil 1'de verilen model bileşenlerinin detaylı anlatılması ve uygulama kapsamında üç ana başlık altında sunulabilir: i) Optimizasyon ara yüzü ve modelleri, ii) Kullanıcı ara yüzü, iii) Kampüs binasında uygulama. Bu ön çalışma kapsamında, kampüs binalarında ve ulaşımında enerji verimliliği artırma yöntemleri, yenilenebilir enerji üretimi ve depolaması ve bunlar için optimizasyon modelleri kurma kısımları üzerine çalışılmıştır. Şekil-1'deki merkezi ısıtma-soğutma optimizasyonu ve optimizasyon modellerinin GreenMetric sistemine entegrasyonu bu aşamada dahil edilmemiştir.

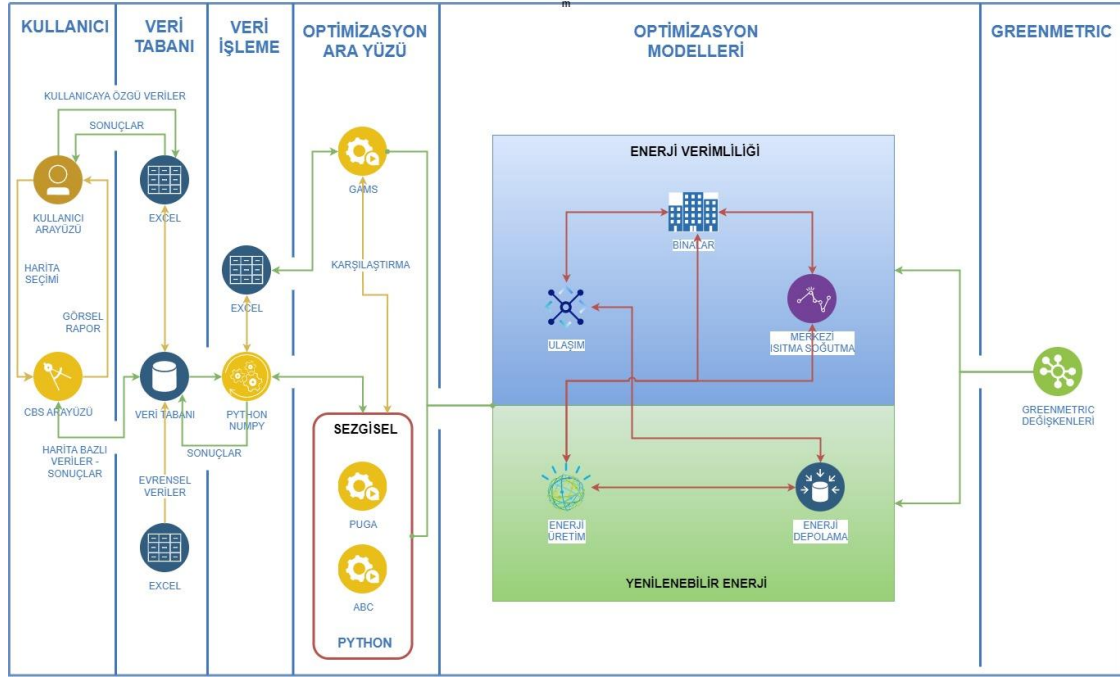

Şekil 1 - Kampüs Enerji Planlama ve Optimizasyon Modeli Bileşenleri

### 3.1 Optimizasyon Modelleri

Bir optimizasyon modelinin dört ana unsuru vardır: i) karar değişkenleri, ii) kısıtlar, iii) parametreler ve iv) amaç fonksiyonları. Binalarda enerji verimliliği optimizasyon modelinde, literatürdeki örnekler taranarak, (1) bina dış kabuğu, (2) binanın enerji sistemi, (3) aydınlatma sistemi ve (4) elektrikli aletler kapsamında 20 grup karar değişkeni belirlenmiştir.

#### i) Karar değişkenleri

(1) Bina dış kabuğu kapsamında karar değişkenleri: Farklı tipte malzeme katmanlarına sahip kapı tipi, pencere tipi, duvar tipi için karar değişkenleri bulunmaktadır. Örneğin her duvar tipi bir dizi bilinen ve eklenecek olan katmandan oluşur. Aynı durum tavan ve zemin tipini ifade eden karar değişkenleri için de geçerlidir.

(2) Bina enerji sistemi kapsamında karar değişkenleri: Elektrikli veya elektriksiz ısıtma sistemleri (sadece ısıtma), elektrikli soğutma sistemleri (yalnızca elektrikli soğutma), elektrikli veya elektriksiz sıcak su sistemleri, ısıtma-soğutma sistemleri (hem ısıtma hem soğutma), ısıtma-sıcak su sistemleri (hem mekân ısıtma hem sıcak su besleme), güneş enerjisi sistemleri (sıcak su için), yenilenebilir elektrik üretim sistemleri.

(3) Aydınlatma sistemi kapsamında karar değişkenleri: Çeşitli kategorilerde aydınlatma seçenekleri

(4) Elektrikli aletler kapsamında karar değişkenleri: Çeşitli kategorilerde elektrikli alet seçenekleri

Literatürden incelenen örnekler karşılaştırıldığında, yukarıda listelenen karar değişkenlerinin daha gerçekçi olması için sürekli değişken yerine ikili (*binary*) değişkenler olmasına karar verilmiştir. Bina dış kabuğu, farklı tipte malzeme katmanlarına sahip duvar, tavan ve zemin, kapılar ve pencerelerden oluşur. Katmanların malzemeleri belirli bir ısı iletkenliğe ve kalınlığa sahiptir. Karar değişkenleri için örnek modeller aşağıda verilmiştir. Benzer denklemler gösterilmemiştir.

a. Kapılar: Mevcut alternatif kapı sayısı  $D$  olsun.  $d = 1, \dots, D$  olmak üzere, karar değişkeni  $x_d^{DOOR}$  şu şekilde tanımlanır:

$$x_d^{DOOR} = \begin{cases} 1, & \text{kapı tipi olarak } d \text{ seçilirse} \\ 0, & \text{diğerleri için} \end{cases} \quad (1)$$

Önerilen mevcut kapıların aynı tipte olduğu ve yalnızca birinin seçilebileceği varsayılır, bu da aşağıdaki kısıtlamaya yol açar:

$$\sum_{d=1}^D x_d^{DOOR} = 1 \quad (2)$$

Pencereler ve duvarlar kapılara benzer şekilde modellenmiştir. Fakat, her duvar yapısı  $NWL_w$  sayısı bilinen katmanlardan oluşur ( $nwl = 1, \dots, NWL_w$ ). Bu tabakaların malzemelerinin özel ısı iletkenlikleri  $kk_{w;nwl}^{IWALL}$  (W/m K) ve kalınlıkları  $l_{w;nwl}^{IWALL}$  (m)'dir. Ayrıca  $Y_w$  ( $y = 1, \dots, Y_w$ ), malzemelerinin mevcut olanlar arasından seçilmesi gereken bilinmeyen katmanların (örneğin yalıtım) katman sayısı olsun. Yapının bilinmeyen her  $y$  katmanı için  $P_{wy}$  ( $p = 1, \dots, P_{wy}$ ) alternatif malzemeler mevcuttur ve ilgili yapı için yalnızca birinin seçilmesine izin verilir. Bu nedenle, aşağıdaki karar değişkeni ve kısıtlaması tanımlanmıştır:

$$x_{wyp}^{mWALL} = \begin{cases} 1, & w \text{ duvar yapısının } y \text{ katmanı için } p \text{ malzemesi seçilirse} \\ 0, & \text{diğerleri için} \end{cases} \quad (3)$$

$$\sum_{p=1}^{P_{wy}} x_{wyp}^{mWALL} = x_w^{WALL} \quad (y = 1; \dots; Y_w \quad \forall w = 1 \dots W) \quad (4)$$

Tavanlar ve zeminler, duvarlara benzer şekilde modellenmiştir.

Bu metodolojide varsayılan enerji sistemleri kategorileri şunlardır:

- Isıtma sistemleri: Sadece ısıtma sağlar ve giriş yakıtlarına göre elektrikli veya elektriksiz sistemler olabilir.
- Soğutma sistemleri: Yalnızca soğutma sağlar (yalnızca elektrikli sistemlerin mevcut olduğu varsayılır).
- Doğrudan Sıcak Su (DSS) sistemleri: Sadece sıcak su sağlar. Yakıtlarına göre elektrikli veya elektriksiz olabilirler. Modellemede DSS yerine DHW kullanılmıştır
- Isıtma-soğutma sistemleri: Hem alan ısıtma hem de soğutma sağlar (yalnızca elektrikli sistemlerin mevcut olduğu varsayılır).
- Isıtma-soğutma sistemleri: Hem alan ısıtma hem de soğutma sağlar (yalnızca elektrikli sistemlerin mevcut olduğu varsayılır).
- Isıtma–DSS sistemleri: Hem alan ısıtma hem de DSS beslemesi sağlar. Yakıtlarına göre elektrikli veya elektriksiz olabilirler.
- Güneş kolektör sistemleri: Güneş enerjisini kullanarak DSS sağlar.
- Elektrik üretim sistemleri: YEK kullanarak elektrik sağlar.

Yukarıdaki sistemlerle ilgili örnek karar değişkenleri aşağıdaki gibi tanımlanmıştır.

$$x_{ehsi,ehsj}^{EHS} = \begin{cases} 1, & ehsi \text{ kategorisinde bir elektrikli ısıtma sistemi eh sj seçilirse} \\ 0, & \text{diğerleri için} \end{cases} \quad (5)$$

$$x_{nehsi,neh sj}^{NEHS} = \begin{cases} 1, & neh si kategorisindeki elektrikli olmayan bir ısıtma sistemi neh sj seçilirse \\ 0, & \text{diğerleri için} \end{cases} \quad (18)$$

$$x_{ehcsi,ehcsj}^{ECS} = \begin{cases} 1, & ehcsi kategorisinde bir elektrikli soğutma sistemi ehcsj seçilirse \\ 0, & \text{diğerleri için} \end{cases} \quad (6)$$

Mevcut olanlar arasında alan ısıtma sistemi seçimini Denklem (7) sağlar:

$$\sum_{ehsi=1}^{EHSI} \sum_{ehsj=1}^{EHSJ_{ehi}} x_{ehsi,ehsj}^{EHS} + \sum_{nehsi=1}^{NEHSI} \sum_{neh sj=1}^{NEHSJ_{ehi}} x_{neh si,neh sj}^{NEHS} + \sum_{ehcsi=1}^{EHCSI} \sum_{ehcsj=1}^{EHCSJ_{ehci}} x_{ehcsi,ehcsj}^{ECS} + \sum_{ehwsi=1}^{EHWSI} \sum_{ehwsj=1}^{EHWSJ_{ehwsi}} x_{ehwsi,ehwsj}^{EHWS} + \sum_{nehwsi=1}^{NEHWSI} \sum_{nehwsj=1}^{NEHWSJ_{ehwsi}} x_{nehwsi,nehwsj}^{NEHWS} = 1 \quad (7)$$



Soğutma sistemi seçimi ve DSS sistemi seçimi benzer şekilde modellenir. DSS sağlamak için güneş kolektör sistemi seçimi ise şöyledir:

$$\sum_{slci=1}^{SLCI} \sum_{slcj=1}^{SLCJ} x_{slci,slcj}^{SLC} \leq 1 \quad (8)$$

YEK elektrik sistemi seçimi de buna benzerdir. Farklı lambalardan oluşan mevcut aydınlatma sistemi için karar değişkeni ve elektrikli ev aletleri kapı ve pençelere benzer modellenmiştir.

### ii) Kısıtlar ve Hesaplamalar

Modelin kısıtları, ısıtma, soğutma, sıcak su sistemi, aydınlatma sistemi ve elektrikli aletler için gerekli enerji taleplerinin karşılanması gibi enerji dengelerini ifade eden matematiksel formüllerdir. Örneğin, birincil enerji tüketimi hesabı için tüm sistemlerin enerji tüketimleri, verimlilik, enerji kayıp ve kazançları, ısı ve enerji transferleri, ortam sıcaklıkları vb. parametreler kullanılarak detaylı bir şekilde hesaplanmaktadır. Ayrıca enerji talebini karşılamak için bir ekipmanın seçimi ile ilgili kısıtlamalar vardır. Örneğin, bir ekipman birden fazla amaç için kullanıldığında bunu belirten kısıt fonksiyonları modellenmiştir. Ek olarak, yatırım maliyeti her bir kategori için seçilen ekipmana bağlı olarak hesaplanır. Herhangi bir güçlendirme eyleminden önce mevcut binanın birincil enerji tüketimi hesaplanmalıdır. Bir binadaki toplam yıllık birincil enerji tüketimi, ısıtma, soğutma, DSS, aydınlatma ve elektrikli ev aletleri için kullanılan birincil enerjidir.

$$Q_T = Q_H + Q_C + Q_{DHW} + Q_L + Q_A \quad (9)$$

Yıllık olarak, ısıtma için toplam yıllık birincil enerji tüketimi şuna eşit olacaktır:

$$Q_H = \frac{Q_{el}^H f^{grid}}{n_{grid}} + \sum_{fuel=1}^{FUEL} Q_{nel,fuel}^H \quad (10)$$

Burada,  $Q_{el}^H$  bir elektrik sistemi tarafından ısıtma amacıyla tüketilen enerji (MJ/yıl),  $f^{grid}$  şebekeden elektrik arzının yüzdesi (YEK elektrik arzı birincil enerji tüketimine katkıda bulunmaz),  $n_{el}$  şebekeden binaya elektrik beslemesi için ortalama verim,  $Q_{nel,fuel}^H$  yakıt kullanan elektrik olmayan bir sistem tarafından tüketilen enerjidir. Bir elektrikli ve elektriksiz sistem tarafından tüketilen enerji şu şekilde hesaplanabilir:

$$Q_{el}^H = Q^{HD} SEH_{EL} \quad (11)$$

$$Q_{nel,fuel}^H = Q^{HD} SEH_{nel,fuel} \quad (12)$$

$Q^{HD}$  toplam yıllık ısıtma enerjisi talebi (MJ/yıl),  $SEH_{el}$  ve  $SEH_{nel,fuel}$  ısıtma için seçilen sistemin verimliliği olmak üzere şöyle hesaplanır:

$$SEH_{el} = \sum_{ehst=1}^{EHSI} \sum_{ehsj=1}^{EHSJ} \left( \frac{x_{ehsi,ehsj}^{EHS}}{n_{ehsi,ehsj}^{EHS}} \right) + \sum_{ehcsi=1}^{EHCSI} \sum_{ehcsj=1}^{EHCSJ} \left( \frac{x_{ehcsi,ehcsj}^{EHCS}}{n_{ehcsi,ehcsj}^{EHCS}} \right) + \sum_{ehwsi=1}^{EHWSI} \sum_{ehwsj=1}^{EHWSJ} \left( \frac{x_{ehwsi,ehwsj}^{EHWS}}{n_{ehwsi,ehwsj}^{EHWS}} \right) \quad (13)$$

$$SEH_{nel,fuel} = \sum_{nehsi=1}^{NEHSI} \sum_{nehjsj=1}^{NEHSJ} \left( \frac{x_{nehsi,nehjsj}^{NEHS}}{n_{nehsi,nehjsj}^{NEHS}} \right) + \sum_{nehwsi=1}^{NEHWSI} \sum_{nehwsj=1}^{NEHWSJ} \left( \frac{x_{nehwsi,nehwsj}^{NEHWS}}{n_{nehwsi,nehwsj}^{NEHWS}} \right) \quad (14)$$

$n_{nehsi,nehjsj}^{NEHS}$ ,  $n_{ehcsi,ehcsj}^{EHCS}$ ,  $n_{ehwsi,ehwsj}^{EHWS}$  ilgili kategorilerdeki elektrik sistemlerinin verimliliği,  $n_{nehsi,nehjsj}^{NEHS}$ ,  $n_{nehwsi,nehwsj}^{NEHWS}$  elektriksiz sistemlerin ilgili kategorilerinin verimliliğidir. Yıllık ısıtma talebi, her ayın talebi toplanarak hesaplanabilir. Her ay için ısıtma talebi aylık iletim,  $Q_{T,m}$  (kW h/ay) ve havalandırma kayıpları,  $Q_{VEN,m}$  (kWh/ay) ile dahili ısı kazançları,  $Q_{INHG,m}$  (kW h/ay) ve güneşten ısı kazancı,  $Q_{SL,m}$  (kW sa/ay) farkı kadardır. Güneş kazançları ile ilgili olarak, sadece az miktarda bir ısı kazancı sunmalarına rağmen, sadece pencereden doğrudan gelen güneş kazançları dikkate alınır, dolaylı olan (duvarların güneş ışınlarının soğurulması gibi) kazanımlar dikkate alınmaz. İlgili hesaplamalar şöyledir:

$$Q_m^{HD} = \begin{cases} HS_m F_{conv} (Q_{T,m} + Q_{VEN,m} - Q_{INHG,m} - Q_{SL,m}), & \text{eğer pozitifse} \\ 0, & \text{diğerleri için} \end{cases} \quad (15)$$

$$Q_{T,m} = BLC(T_{IH} - T_{o,m})t_m \quad (16)$$

$$Q_{VEN,m} = \rho_{air} c_{\rho_{air}} ACH.V. \frac{(T_{IH} - T_{o,m}) t_m}{3600} \quad (17)$$

$$Q_{INHG,m} = (n_{people} Q_{people,m} + Q_{eah,m}) t_m \quad (18)$$

$$Q_{SL,m} = \sum_{wn=1}^{WN} \left( A_{wn}^{WIN} F_{F,wn} F_{S,wn} F_{CM,wn} I_{SL,wn,m} t_d \sum_{s=1}^Z \sum_{t=1}^{T_z} (x_{st}^{WIN} g_{st}^{WIN}) \right) \quad (19)$$

### iii) Parametreler

Modelin parametreleri, genel olarak meteorolojik veriler, teknik katsayılar, talep ve tüketim verileri, verimlilik oran veya katsayıları, boyutlar ve maliyetlerdir. Bu verilerin çoğunun kullanıcılar tarafından eklenmesi gerekir. Örneğin, enerji ihtiyacının hesaplanması için hava sıcaklığı, güneş radyasyonu, su sıcaklığı, binayı kullanan kişi sayısı ve binanın boyutları gereklidir. Aydınlatma ve elektrikli ev aletlerinin birincil enerji tüketiminin hesaplanması için lamba ve cihazların sayısı ve çalışma saatleri, hesaplamalar için seçilen ekipmanın ve elektrik şebekesinin verimlilik katsayıları, toplam yatırım maliyetinin hesaplanması için bileşenlerin maliyetleri gibi parametreler kullanıcı tarafından modele eklenmelidir. Kurulacak olan yazılımın kullanıcı dostu olması ve kullanıcının veri girme yükünü azaltması açısından, gerekli verilerin mümkün olduğunca otomatik oluşturulması amaçlanmaktadır.

### iv) Amaç fonksiyonları

Literatürde yapılan araştırmalar sonucunda tez çalışması için hazırlanan optimizasyon modellerinin çok amaçlı olması gerektiği görülmüştür [1, 8, 14, 16]. Çok amaçlı optimizasyon hem daha gerçekçi bir tasarım sunar hem de karar vericilerin çeşitli alternatifleri kıyaslamasını sağlar. Ayrıca, hedeflerimizden biri olan GreenMetric uyumlu bir model için de amaç fonksiyonlarından birinin GreenMetric puanının maksimize edilmesi olacaktır. Diğer amaç fonksiyonları, yıllık toplam birincil enerji tüketiminin minimizasyonu ve toplam yatırım maliyetinin minimizasyonu olarak belirlenmiştir. Örneğin, bileşenlerin ilk satın alma maliyeti ve kurulum maliyeti olarak tanımlanan ilk yatırım maliyeti kullanılır. nerilen bileşenler için ilk yatırım maliyeti şöyledir:

$$INV\text{COST} = \text{COST}_{DOR} + \text{COST}_{WIN} + \text{COST}_{WAL} + \dots + \text{COST}_{LIGHT} + \text{COST}_{EA} \quad (20)$$

Her bir bileşenin maliyeti birbirinden bağımsız olarak, şu şekilde hesaplanabilir:

$$\text{COST}_{DOR} = \sum_{dr=1}^{DR} (A_{dr}^{DOR}) \sum_{d=1}^D (x_d^{DOR} C_d^{DOR}) \quad (21)$$

$$\text{COST}_{WIN} = \sum_{wn=1}^{WIN} (A_{wn}^{WIN}) \sum_{s=1}^S \sum_{t=1}^{T_s} (x_{st}^{WIN} C_{st}^{WIN}) \quad (22)$$

$$\text{COST}_{WAL} = \sum_{wl=1}^{WAL} (A_{wl}^{WAL}) \sum_{w=1}^W \left( x_w^{WAL} \left( \sum_{nwl=1}^{NWL_w} (C_{w,nwl}^{mWALL}) + \sum_{y=1}^{Y_w} \left( \sum_{p=1}^{P_{wy}} (x_{wyp}^{mWALL} C_{wyp}^{mWALL}) \right) \right) \right) \quad (23)$$

Burada  $C_d^{DOR}$   $d$  tipi bir kapı için ilk yatırım maliyeti,  $C_{zt}^{WIN}$   $z$  tipi ve  $t$  alt tipi bir pencere için ilk yatırım maliyeti,  $CK_{w,nwl}^{mWALL}$   $CK_{d,ncl}^{mCEIL}$ ,  $CK_{h,nfl}^{mFLO}$  duvar yapısı  $w$ ,  $ncl$  tavan yapısı  $r$  ve  $nfl$  zemin yapısı  $h$  bilinen katmanlarında kullanılan malzemeler için ilk yatırım maliyetleri,  $C_{wyp}^{mWALL}$ ,  $C_{rfa}^{mCEIL}$ ,  $C_{heg}^{mFLO}$   $w$  duvar yapısının bilinmeyen  $y$  tabakasında kullanılan  $p$  malzemesinin,  $r$  tavan yapısının bilinmeyen tabakasında kullanılan  $a$  malzemesinin ve zeminin bilinmeyen  $e$  tabakasında kullanılan  $g$  malzemesinin ilk yatırım maliyetleridir. Yeni bir binada enerji verimliliği önlemlerinin optimal önceliklendirilmesini belirlemek için, birincil enerji tüketimi ve ilk yatırım maliyeti kriterleri en aza indirilmelidir:

$$\min[g_1(\mathbf{x})] = Q_T$$

$$\min[g_2(\mathbf{x})] = INV\text{COST} \quad (24)$$

Mevcut bir binayı güçlendirme durumunda da metodoloji yeni bir binanınkine benzerdir. Ancak bu durumda hedefler, minimum ilk yatırım maliyeti ile maksimum birincil enerji tasarrufu elde etmek olacaktır. Bu nedenle, herhangi bir güçlendirme işleminden önce mevcut binanın birincil enerji tüketimi hesaplanmalıdır. Ayrıca, mevcut bir bina teorik olarak birden fazla kapı, pencere vb. içerebileceğinden, bina kabuğunun bileşenlerine ilişkin kısıtlamalar geçerli olmayabilir. Mevcut bir binanın toplam yıllık birincil enerji tüketimi şuna eşittir:

$$Q_{T-pre} = Q_H + Q_C + Q_{DHW} + Q_L + Q_A \quad (25)$$

Burada  $Q_{T-pre}$  herhangi bir güçlendirme işleminden önceki yıllık birincil enerji tüketimini ifade eder. Bir binada iyileştirmeler sonrası birincil enerji tüketimini ( $Q_{T-post}$ ) hesaplamak için önceki prosedür tekrar izlenir. Ayrıca, mevcut bir binanın güçlendirilmesi durumunda duvar, tavan ve döşeme yapılarının değişmeyeceği varsayılmaktadır. Yalıtım katmanları bazı bileşenlerde bulunabileceği gibi diğer bileşenlere de uygulanabilir. Bir binanın güçlendirilmesi için bileşenlerin ilk yatırım maliyeti, önerilen bileşenlerin maliyet alımını ve kurulumunu temsil eder.  $Q_{w,kwl}^{mWALL}$ ,  $Q_{d,kcl}^{mCEIL}$ ,  $Q_{d,kfl}^{mFLO}$  değişkenleri zaten var oldukları için sıfıra eşittir. En iyi çözümü bulma kriterleri, enerji tasarrufu ve yatırımın başlangıç maliyetidir. Bu durumda enerji tasarrufu maksimize edilmeli ve yatırım maliyeti minimize edilmelidir:

$$\max[g_1(\mathbf{x})] = Q_{T-pre} - Q_{T-post}$$

$$\min[g_2(\mathbf{x})] = INVCOST \quad (26)$$

$Q_{T-pre}$ 'nin modelin sabit bir parametresi olduğu göz önüne alındığında, denklem (26)'in birinci amaç fonksiyonu aslında denklem (24)'in birinci amaç fonksiyonuna eşdeğerdir.

#### 4. SONUÇ

Kampüs binaları ve ulaşımı için enerji planlama ve optimizasyon modelleme çalışmamızda geniş literatür taraması yapılarak, bina kabuklarının yalıtılması, ısı merkezine kojenerasyon sisteminin kurulması, aydınlatma sistemlerinin verimliliştirilmesi, PV kurulumuyla birlikte çatı güçlendirme ve yalıtımı, pencere değişimi ve renkli pencere kullanımı, ısıtma sistemlerinde biyokütle veya ısı pompaları kullanılması, klima ayarlarının optimizasyonu, ısı geri kazanım sistemlerinin kurulumu, HVAC için düzenlemeler ve LED lambalarının otomatik kontrolü gibi enerjinin verimli kullanılabilmesi noktalar tespit edilmiştir. Bina verimliliğini arttırmak için gerekli optimizasyon modeli kurularak ilgili kodlamalar yapılmıştır. Kampüs enerji planlama ve optimizasyon modelinin yazılım olarak tamamlanmasının ardından model, Erciyes Üniversitesi kampüsünde enerji planlama ve optimizasyonu için kullanılacaktır. Erciyes Üniversitesi, toplam 19 fakülte, 1 yüksekokul, 2 meslek yüksekokulu, 7 enstitü, 6 bölüm, 42 araştırma merkezi ve 1350 yataklı gelişmiş bir uygulama hastanesi ile hizmet vermektedir. Fakat, araştırmanın kapsamı üniversitenin tüm kampüsü olmayacaktır. Hedef yazılım gerçek bir kampüs için test emek olduğundan, kampüsün bir kısmı üzerinde çalışılacaktır. Bu hedefin başarıyla tamamlanabilmesi için, belirlenecek binalar, merkezi ısıtma sisteminin bir kısmı, ulaşım sisteminin bir kısmı, yenilenebilir enerji planlaması, enerji depolama imkanları vb. için veriler toplanmalıdır. Örnek kampüs hesaplaması için Erciyes Üniversite kampüsünden uygun bir bina seçilerek tüm veriler toplanmıştır. Bina enerji verimliliği ve tasarrufu için güncel malzeme fiyatları, bu malzemelerin teknik özellikleri hesaplamalar için hazırlanmıştır. Bu aşamada araştırmanın sonuçlanması için çözümleme programları karşılaştırılmaktadır. Ayrıca araştırmada yer alan kampüs içi ulaşım optimizasyon yöntemleri bulma çalışmaları devam etmektedir.

#### 5. KAYNAKLAR

1. Karmellos, M., A. Kiprakis, and G. Mavrotas, *A multi-objective approach for optimal prioritization of energy efficiency measures in buildings: Model, software and case studies*. Applied Energy, 2015. **139**: p. 131-150.
2. Arık, S., *Sürdürülebilir çevre eğitimi ile ilgili tezlerin eğilimleri: Bir sistematik inceleme*. Uluslararası Bilim, Eğitim, Sanat ve Teknoloji Sempozyumu (UBEST-2019)(02-04 Mayıs 2019), İzmir, 2019.
3. RÜŞEN, S.E., et al., *Üniversite Kampüs Binaları için Enerji Etüdü: Örnek Çalışma*. Çukurova Üniversitesi Mühendislik-Mimarlık Fakültesi Dergisi, 2018. **33**(2): p. 83-92.
4. Han, Y., X. Zhou, and R. Luo, *Analysis on campus energy consumption and energy saving measures in cold region of China*. Procedia Engineering, 2015. **121**: p. 801-808.
5. Bellia, L., et al., *University building: Energy diagnosis and refurbishment design with cost-optimal approach. Discussion about the effect of numerical modelling assumptions*. Journal of Building

- Engineering, 2018. **18**: p. 1-18.
6. Chin, Y.M., *Analysis of campus building energy optimization based on energy plus software simulation/Chi Yi Ming*. 2018, University of Malaya.
  7. Murray, P., et al., *Optimal transformation strategies for buildings, neighbourhoods and districts to reach CO2 emission reduction targets*. Energy and Buildings, 2020. **207**: p. 109569.
  8. Ascione, F., et al., *Energy retrofit of educational buildings: Transient energy simulations, model calibration and multi-objective optimization towards nearly zero-energy performance*. Energy and Buildings, 2017. **144**: p. 303-319.
  9. Guerrieri, M., et al., *University campuses as small-scale models of cities: Quantitative assessment of a low carbon transition path*. Renewable and Sustainable Energy Reviews, 2019. **113**: p. 109263.
  10. Tan, B., et al., *Optimal selection of energy efficiency measures for energy sustainability of existing buildings*. Computers & Operations Research, 2016. **66**: p. 258-271.
  11. Koç, H.E., *Environmental sustainability of university campuses: A practical assessment tool*. 2014, Middle East Technical University.
  12. Lin, Y., M. Liu, and W. Yang, *Energy efficiency measures for a high-tech campus in California based on total performance oriented optimization and retrofit (TPOR) Approach*. Procedia Engineering, 2015. **121**: p. 75-81.
  13. Jafari, A. and V. Valentin, *Selection of optimization objectives for decision-making in building energy retrofits*. Building and Environment, 2018. **130**: p. 94-103.
  14. Ascione, F., et al., *Knowledge and energy retrofitting of neighborhoods and districts. A comprehensive approach coupling geographical information systems, building simulations and optimization engines*. Energy Conversion and Management, 2021. **230**: p. 113786.
  15. Yildiz, Y. and M. Koçyiğit. *A study on the energy-saving potential of university campuses in Turkey*. in *Proceedings of the Institution of Civil Engineers-Engineering Sustainability*. 2020. Thomas Telford Ltd.
  16. Abdul-Azeez, I.A. and C.S. Ho, *Realizing low carbon emission in the university campus towards energy sustainability*. Open Journal of Energy Efficiency, 2015. **4**(02): p. 15.
  17. Kaplan, D.H., *Transportation sustainability on a university campus*. International Journal of Sustainability in Higher Education, 2015.
  18. Guo, T., et al., *Emerging Technologies and Methods in Shared Mobility Systems Layout Optimization of Campus Bike-Sharing Parking Spots*. Journal of Advanced Transportation, 2020. **2020**.
  19. Suat, O. and S.B. Efe, *Elektrikli bisikletle paylaşımlı hareketlilik: Balıkesir Üniversitesi Kampüsü örneği*. Akıllı Ulaşım Sistemleri ve Uygulamaları Dergisi. **3**(2): p. 216-226.
  20. Zimmer, K., et al. *Using data analytics to optimize public transportation on a college campus*. in *2018 IEEE 5th international conference on data science and advanced analytics (DSAA)*. 2018. IEEE.
  21. Altıntasi, O. and H. Tuydes-Yaman. *Assessing Sustainable Campus Transportation Policies for METU: Policies for In-Campus Mobility*. in *Proceedings of the 10th International Congress on Advances in Civil Engineering, Middle East Technical University*. 2012.
  22. Bustillos, B.I., J. Shelton, and Y.-C. Chiu, *Urban university campus transportation and parking planning through a dynamic traffic simulation and assignment approach*. Transportation planning and technology, 2011. **34**(2): p. 177-197.
  23. Nematchoua, M.K., *From existing neighbourhoods to net-zero energy and nearly zero carbon neighbourhoods in the tropical regions*. Solar Energy, 2020. **211**: p. 244-257.
  24. Bowman, A., "You can get there from here": *Campus Transportation Practices: What They Are, And What They Could Be*. Coastlines, 2017. **1**(5): p. 5.
  25. Chowdhury, N., et al., *Optimization of solar energy system for the electric vehicle at university campus*

*in Dhaka, Bangladesh. Energies*, 2018. **11**(9): p. 2433.

26. Deveci, K. and Ö. Güler, *A CMOPSO based multi-objective optimization of renewable energy planning: Case of Turkey*. *Renewable Energy*, 2020. **155**: p. 578-590.
27. Dhunny, A., et al., *Sustainable renewable energy planning and wind farming optimization from a biodiversity perspective*. *Energy*, 2019. **185**: p. 1282-1297.
28. Eriksson, E. and E.M. Gray, *Optimization of renewable hybrid energy systems—A multi-objective approach*. *Renewable energy*, 2019. **133**: p. 971-999.
29. Arnette, A. and C.W. Zobel, *An optimization model for regional renewable energy development*. *Renewable and Sustainable Energy Reviews*, 2012. **16**(7): p. 4606-4615.
30. Aydin, N.Y., E. Kentel, and H.S. Duzgun, *GIS-based site selection methodology for hybrid renewable energy systems: A case study from western Turkey*. *Energy conversion and management*, 2013. **70**: p. 90-106.
31. UN Sustainable Development Goals, Turkey, Voluntary National Review 2019, <https://sustainabledevelopment.un.org/memberstates/turkey>.



## IMPROVEMENTS OF NEXT GENERATION IOT APPLICATIONS SECURITY CHALLENGES

Zeynep PEKDEMİR<sup>1,2</sup>, Ahmet Gürkan YÜKSEK<sup>3,4</sup>, Derya Betül ÜNSAL<sup>1,2</sup>

<sup>1</sup> Energy and Technology Engineering Department, Sivas Cumhuriyet University

<sup>2</sup> Renewable Energy Research Center, Sivas Cumhuriyet University

<sup>3</sup> Computer Engineering Department, Sivas Cumhuriyet University

<sup>4</sup> Artificial Intelligence Systems and Data Science Application and Research Center, Sivas Cumhuriyet University

### ABSTRACT

The IoT infrastructure has many different components within the network, such as cloud, big data, mobile devices, and the Internet of Things, and is conditioned to be able to work with a complex structure that requires these technologies to work synchronized. It is very important to ensure that each component is able to transmit secure data and that security is permanent in order to ensure the continuous availability of these services. Every component of the IoT infrastructure is mostly exposed to various security vulnerabilities and potential threats in real time. The study examined security vulnerabilities and threats on each of the platforms in the infrastructure in detail. IoT infrastructure components were discussed along with techniques and standards for protecting them from these threats and security vulnerabilities. The various smart applications of IoT, smart networks, smart transportation systems, smart water systems, intelligent buildings, and similar applications also discussed security concerns and different ways to solve them, suggesting solutions.

**Keywords:** Iot, Smart Applications, Security

### I. Introduction

The Internet is essential in the dissemination of information. Technology also has a function in applications such as data collecting and control. Consequently, a novel technology known as the Internet of Things (IoT) arises. The Internet of Things (IoT) gathers, manages, evaluates, and links data [1]. Enhancing the quality of life is a primary objective of the Internet of Things. In addition, network systems are susceptible to numerous security flaws [2] and face continuous attacks due to the implementation of network defence technologies such as security software and network security barriers. Once again, the abundance of security software and network security measures are insufficient at this point. Due to cyber threats, a comprehensive, current, efficient security system is employed. Figure 1 shows general scheme of IoT applications.

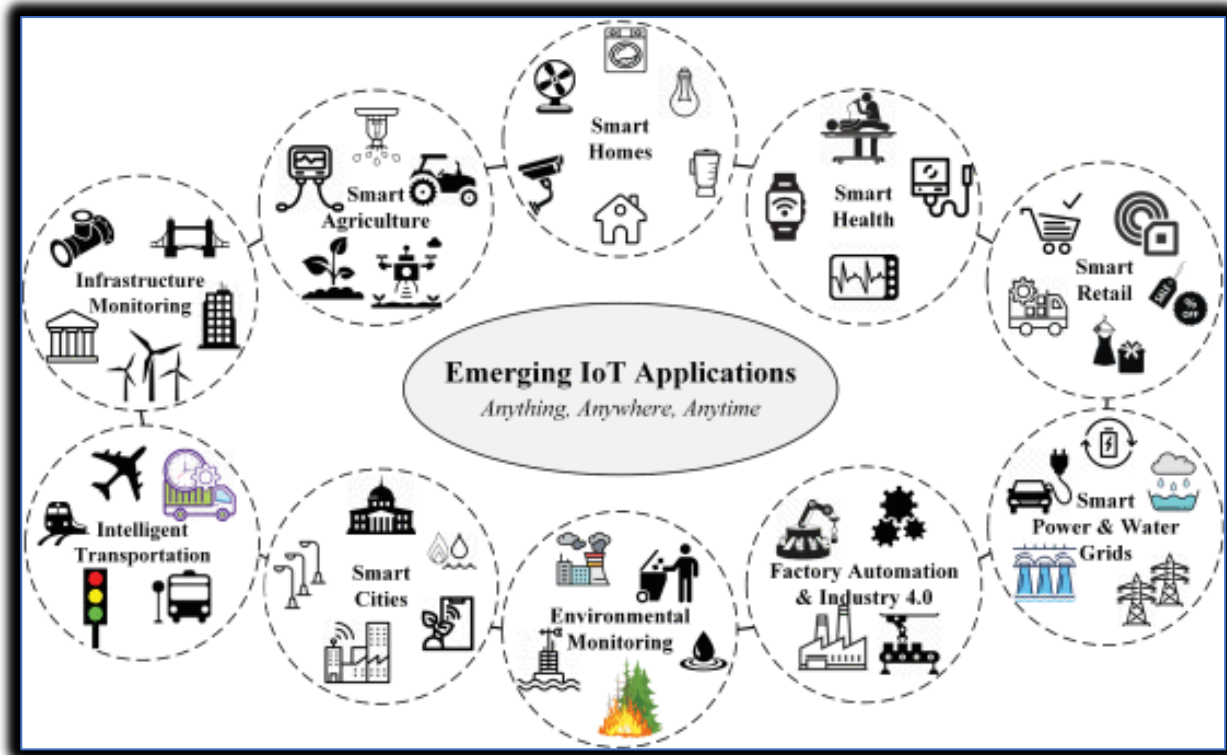

Figure 1. IoT Application General Scheme [2].

## 2. Security vulnerabilities in the Internet of Things (IoT)

This section explain the outline of growing concerns regarding the security aspects of Internet of Things technologies. Hardware security pertains to the operational aspects of devices. Consequently, more characteristics are incorporated at a later stage. Device integrity ensures that codes and fundamental data are safely enabled for the operation of Internet of Things technologies [4]. About regulation, there is still a lack of clarity about the secure utilisation of IoT data. However, any harm resulting from data misuse can potentially be remedied by compensation. In order to guarantee the protection of this data, measures such as the implementation of the General Data Protection Regulation (GDPR) [5] and HIPAA [6] have been put in place. The HIPAA security application incorporates functionalities such as capturing heart rate, weight, blood pressure, and other health metrics, along with advancements in device manufacturing and application.

Personnel, supervisors, and individuals are increasingly recognising the vulnerabilities associated with social engineering and authentication as a result of insufficient security education. DoS and DDoS attacks, which involve consuming resources, including as memory, communication channels, bandwidth, discs, and battery power, are commonly targeted at IoT devices [7].

A security concern in architectural layers involves covertly intercepting the regular data flow to extract valuable information. Within this stratum, malicious software establishes connections with Internet of Things (IoT) systems [8].

Authentication requests are transmitted to IoT devices with limited resources in order to execute software attacks, thereby preventing the device from entering sleep mode. Malicious data injection can also be employed to render IoT systems inaccessible to consumers.

Expanding the number of devices might also give rise to security vulnerabilities. Devices can be replicated and duplicated during the manufacturing and processing stages. An example of a security hazard is the illicit acquisition of passwords and identity information utilised by manufacturers [9].

System developers worldwide prioritise product performance and service over security-oriented tasks. Consequently, systems can be put at risk. One of the risks involved is the presence of malware. This malware

deploys malicious code extracted from inaccessible devices onto various nodes in order to launch attacks on other device systems.

### 3. Causes of vulnerabilities in the IoT (Internet of Things)

Internet of Things (IoT) apps have the capability to gather a substantial amount of data. Verilerin orijinallığı ve gizliliği korunduğunda, sağlıklı sonuçlar elde edilebilir ve büyük kazançlar sağlanabilir.

Privacy: Due to the limited resources of IoT applications, conventional encryption techniques are unavailable. Consequently, it is necessary to use unique passwords in order to guarantee confidentiality [10].

There is a balance between cost, performance, and security in different application domains of IoT [11]. As an illustration, RFID labels attached to electronic tickets may possess limited security capabilities, although they must meet high demands for low power consumption and minimal delays at this particular time.

The uniqueness of the nodes can be compromised by various physical assaults. In addition to verifying the accuracy of the data output from the end nodes, it is also necessary to authenticate the uniqueness of these nodes. Hence, a collection of authentication techniques is being devised to ensure the genuineness of IoT end nodes. These verification techniques employ software methods to authenticate the legitimacy of end nodes. In addition, there are authentication systems that rely on memory and those that rely on time.

SWATT [12], Pioneer [13], and SCUBA [14] are examples of time-based verification methodologies. Software and hardware approaches are employed to ensure network security and facilitate hardware modifications [15].

Security elements like as authentication, access control, and encryption are necessary for devices and users in the IoT system. Prior to authorization, authentication is necessary for these devices. Authentication is necessary at this point in IoT systems because to the varying end nodes, sensors, network architecture, and distinct source structure of IoT devices.

#### **“Authentication is necessary in IoT systems to establish the security protocols.”**

Significant volumes of data are exchanged across diverse networks and subsequently transferred and gathered by IoT network systems from end nodes through various IoT systems. Users can be tracked and their preferences determined by privacy-related measures, such as monitoring heartbeats and fingerprints [16]. Homomorphic encryption is employed in intelligent networks, network systems, and control centres to enable the encryption of texts without the requirement of decrypting the data [17].

Forensic studies of IoT system applications are necessary when the IoT infrastructure is centralised or utilised for conducting an assault. The data, obtained through the use of IoT technology and stored in a centralised system, provides information about the objectives and outcomes of criminal investigations. Given the constraints of limited memory resources, it is necessary to transmit the discovered information to the central hub prior to its storage in IoT devices. Researchers consider IoT forensic research to be a fusion of the network and device-level legal system [18].

Within the realm of the Internet of Things, conventional forensic medical procedures can be partially employed. Nevertheless, there is a lack of comprehensive integration in IoT systems for the purpose of criminal investigation. The adoption of IoT has led to the emergence of certain social concerns in recent years. One of the issues is the failure to meet the obligations of the intelligent services offered by the Internet of Things. To mitigate these disparities in culpability, the liability stages are bolstered by new legislative statutes.

### 4. IoT Standards and Its effects of vulnerabilities

The Internet of Things (IoT) has arisen as a powerful and revolutionary influence in the field of technology, comprising a continuously growing network of networked gadgets. The integration of sensors and software into physical objects enables swift communication, decision-making, and automation. Nevertheless, the growing prevalence of IoT usage also entails a proportional surge in security susceptibilities. Hence, it is imperative to establish acknowledged criteria for mitigating these susceptibilities.



The 'ISO/IEC 27032:2012' is a key standard for mitigating security risks in IoT. This document is a globally recognised standard that offers recommendations for ensuring the security of computer systems and networks. The document delineates the technical measures, operational protocols, and risk mitigation strategies aimed at safeguarding the security of IoT systems. The 'IEC 62443' standard is a crucial need for guaranteeing IoT security, specifically tailored for Industrial Control Systems. This methodology offers a methodical and pragmatic way to ensure the security of ICS, encompassing activities such as risk assessment, system design, and the establishment of security assurance levels.

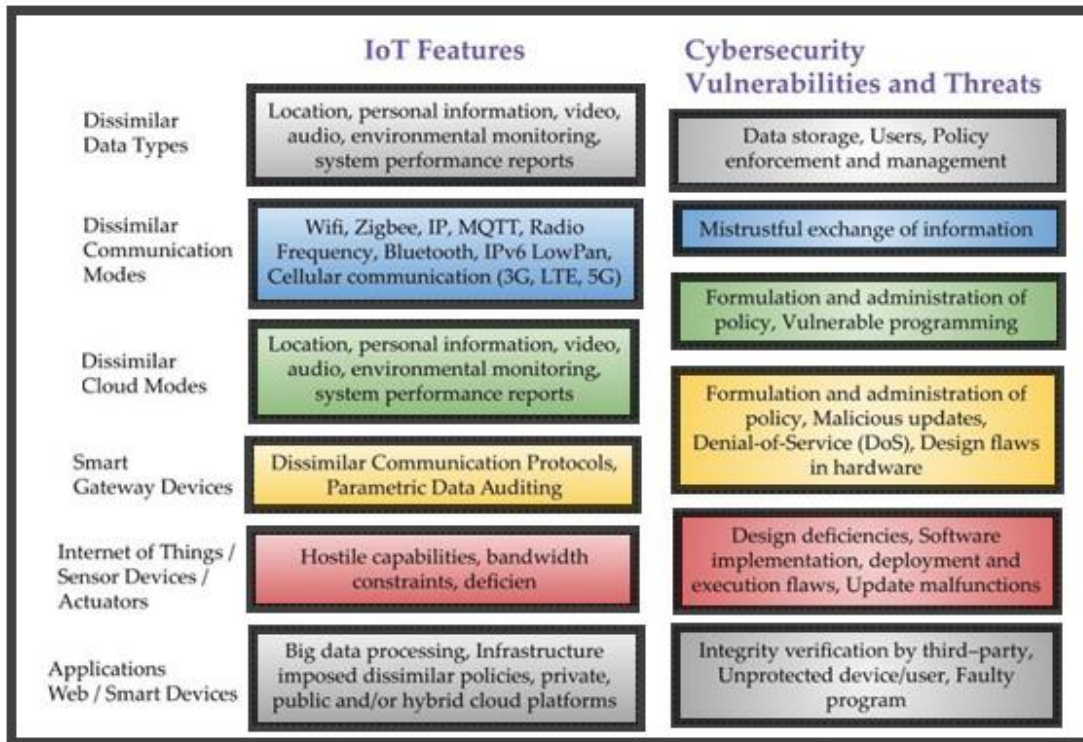

**Figure 2.** IoT Security Features and Vulnerabilities [20].

Furthermore, encryption protocols have a substantial impact on the security of IoT. AES and RSA are frequently utilised in IoT devices to ensure data security. Figure 2 shows IoT security features and vulnerabilities. Adhering to these standards is essential for reducing vulnerabilities in IoT networks. Nevertheless, adopting a proactive strategy that involves identifying and resolving potential risks and vulnerabilities before they can be exploited is crucial for ensuring security. Ultimately, the establishment and execution of acknowledged benchmarks are crucial for mitigating IoT security vulnerabilities. Given the ongoing development of IoT technology, it is imperative to consistently evaluate these standards to ensure their continued effectiveness in the face of constantly changing threats. Collaboration among global regulatory entities, IT corporations, and governments is essential for attaining a more secure Internet of Things (IoT) ecosystem. This provides a comprehensive summary and there are other alternative standards and practices accessible. Further research will yield comprehensive understanding of the precise criteria and directions that these standards offer, hence mitigating IoT security threats.

The interconnected nature of devices in Internet of Things (IoT) applications necessitates the utmost importance of security. Multiple standards and protocols are utilised to guarantee the security of IoT systems. Here are many fundamental criteria that are frequently employed:

1. Transport Layer Security (TLS): Objective: Facilitates the establishment of secure and encrypted communication between devices and servers over a network.

Function: Utilised for the purpose of encrypting data transmissions, verifying the authenticity of devices, and thwarting eavesdropping or tampering.

2. MQTT (Message Queuing Telemetry Transport) is a lightweight messaging protocol designed for IoT devices.

Usage: TLS can be employed to ensure security by implementing authentication, encryption, and authorization protocols for the purpose of secure message exchange.

3. DTLS (Datagram Transport Layer Security) is a protocol that serves the same purpose as TLS, but it is specifically designed to work with unreliable transport protocols such as UDP.

Purpose: Provides a guarantee of safe communication for Internet of Things (IoT) devices, particularly those that function in networks with limited power or unreliable connections.

OAuth, also known as Open Authorization, is a standardised protocol that serves the purpose of token-based authentication and authorization.

Purpose: Facilitates secure entry to IoT devices, permitting third-party apps to retrieve user data without revealing passwords.

5. CoAP (Constrained Application Protocol): Purpose: Protocol designed for IoT devices with limited resources.

Functionality: Facilitates the use of DTLS to establish secure connection, guaranteeing the preservation of data integrity and confidentiality.

6. IEEE 802.1X is a network access control standard.

Purpose: Employed to verify the identity of devices prior to allowing network connectivity, hence deterring unauthorised entry into IoT networks.

7. IoT Security Frameworks: Objective: Inclusive frameworks that offer instructions and optimal methods for ensuring IoT security.

Frameworks such as IoT Security Foundation, IIC Security Framework (Industrial Internet Consortium), and NIST IoT Cybersecurity Framework provide rules for ensuring secure implementation of IoT.

8. Device-Specific Standards: Objective: Different businesses have established security standards specifically designed for different types of IoT devices.

Examples of usage encompass the ISO/IEC 27000 series for comprehensive information security, the NERC CIP for safeguarding critical infrastructure, and the IEC 62443 for protecting industrial control systems.

9. Blockchain: Objective: Offers distributed, immutable data storage and verification.

Application: Primarily utilised in IoT applications, particularly in supply chains and data transactions, to facilitate safe data sharing, maintain traceability, and ensure data integrity.

10. Principles of Security by Design:

Objective: Highlights the integration of security measures during the design and development of Internet of Things (IoT) devices and systems.

Usage: Ensures that security considerations are incorporated from the beginning, encompassing authentication, encryption, access control, and firmware updates.

By incorporating a blend of these established norms, procedures, and structures, the security level of IoT applications may be greatly improved, effectively protecting against any weaknesses and dangers in associated devices and networks.

Implementing strong security standards is a crucial strategy for minimising risks in IoT security. These standards provide manufacturers, developers, and users with guidelines and best practices to guarantee the secure design, deployment, and operation of IoT devices. By strictly following established security protocols, the likelihood of potential weaknesses and malicious attacks can be greatly reduced. The NIST Cybersecurity Framework is a highly acknowledged guideline for ensuring security in the Internet of Things (IoT). The NIST

Cybersecurity Framework offers a systematic method for controlling and mitigating cybersecurity threats associated with IoT devices.

The Internet of Things has fundamentally transformed our technological interactions by effortlessly incorporating intelligent gadgets into our everyday routines. These gadgets possess the capacity to enhance efficiency, convenience, and quality of life in diverse fields such as healthcare, agriculture, transportation, and energy management. Nevertheless, the exponential expansion and widespread acceptance of IoT also give rise to substantial apprehensions surrounding cybersecurity and privacy [19]. IoT devices suffer from a dearth of all-encompassing security solutions [20].

### 5. Softwares and solutions for susceptible of security

To improve the overall security of IoT (Internet of Things) applications, a range of software tools and solutions are used to address security issues. Below are many software categories and solutions employed to address vulnerabilities in IoT applications:

1. IoT Security Platforms: Purpose: These platforms provide a wide range of security services specifically designed for IoT devices and networks.

Functions: Offer comprehensive security solutions for IoT environments, encompassing device authentication, encryption, access control, and threat detection.

2. Security Testing and Assessment Tools: Objective: Software utilised to detect vulnerabilities and flaws in IoT devices and networks.

Tasks: Perform penetration testing, vulnerability scanning, and code analysis to identify and resolve security vulnerabilities.

3. Device Authentication and identification Management Solutions: Objective: Authenticate the identification of devices and guarantee authorised access.

Functions: Utilise authentication methods such as OAuth, certificates, or biometrics to verify the identities of devices and regulate access control.

4. Purpose of safe Communication Protocols and Libraries: To guarantee the encrypted and safe transmission of data between IoT devices and networks.

Functionalities: Incorporate robust communication protocols like TLS, DTLS, MQTT, and libraries that provide encryption and secure transmission of data.

5. Security Analytics and Monitoring Tools: Objective: To oversee IoT networks for any suspicious behaviours and potential security breaches.

Functions: Employ machine learning algorithms and analytics to identify anomalies, intrusions, or anomalous behaviours, facilitating preemptive measures to mitigate threats.

6. Patch Management and Firmware Updates: Objective: Guarantee that devices are operating on the most up-to-date and secure firmware and software versions.

Objective: Streamline the process of applying security fixes to devices in order to mitigate known vulnerabilities and enhance defensive measures.

7. Blockchain-Based Solutions: Objective: Offer secure data storage and verification in decentralised networks, ensuring data integrity.

Objectives: Integrate blockchain technology to provide safe data exchange, transparent transactions, and guarantee data integrity in Internet of Things (IoT) applications.

8. Frameworks and standards for securing the Internet of Things (IoT):

Objective: Recommendations and optimal methods for ensuring the security of IoT environments.

Functions: Comply with recognised security frameworks such as the IoT Security Foundation and NIST IoT Cybersecurity Framework to incorporate security-by-design principles and address vulnerabilities.

9. Cloud Security Services: Objective: Guarantee the secure storage and administration of IoT data in cloud environments.

Functions: Employ cloud security services that provide encryption, access control, and threat detection to protect IoT data.

10. Solutions for Encryption that Cover the Entire Communication Process:

Objective: Employ encryption techniques to safeguard data while it is stored and while it is being transmitted, thereby preventing unauthorised individuals from gaining Access. Develop and apply encryption techniques to ensure the security and privacy of data throughout the whole Internet of Things (IoT) network.

### 6. Results and Suggestions

The IoT infrastructure comprises various network components, including cloud, big data, mobile devices, and the Internet of Things. It is designed to function within a complicated framework that necessitates the synchronisation of these technologies. Each component must possess the capability to securely transmit data and maintain everlasting security to guarantee the uninterrupted availability of these services. Each element of the Internet of Things (IoT) architecture is frequently susceptible to a range of security vulnerabilities and potential threats in real-time. The study conducted a thorough analysis of the security vulnerabilities and threats present on each platform of the infrastructure. The discussion has covered the various components of IoT infrastructure, as well as the approaches and standards used to safeguard it from potential threats and security flaws. The discussion has also covered IoT's diverse applications, such as smart networks, smart transportation systems, smart water systems, and intelligent buildings. It has proposed answers to security issues and explored alternative approaches to addressing them.

It is essential to utilise a combination of these software tools and solutions to effectively deal with weaknesses and improve the security of IoT applications. This will guarantee the safeguarding of data, devices, and networks in the interconnected IoT environment.

Enhancing IoT (Internet of Things) application security by following standards serves multiple important functions, guaranteeing a strong and durable security structure inside IoT ecosystems:

#### **Setting Initial Security Guidelines:**

Initial standards offer a collection of optimal methods and principles for creating, implementing, and overseeing safe IoT systems. Furthermore, it provides a standardised framework that guarantees a uniform foundation for security across various IoT devices, networks, and applications.

#### **Addressing Vulnerabilities and Threats:**

Security standards provide guidelines for implementing methods to identify, address, and reduce vulnerabilities and possible threats in IoT deployments. Furthermore, it aids in the prevention of the exploitation of well-known vulnerabilities, hence diminishing the likelihood of unauthorised access, data breaches, or compromise of the system.

#### **Enabling Interoperability and Compatibility:**

Establish protocols and interfaces that encourage the exchange of information and cooperation between various IoT devices and platforms, ensuring that different devices and systems can work together while adhering to security standards, thus facilitating smooth communication and collaboration.

#### **Guaranteeing Data Security and Confidentiality:**

Establish mechanisms to safeguard sensitive data and protect user privacy in IoT contexts. And also, implements protocols for encrypting, controlling access to, and anonymizing data, thereby protecting user information and avoiding unauthorised data disclosure.

### **Facilitating adherence to regulatory requirements:**

Conforming to established standards helps fulfil regulatory requirements and compliance duties for IoT security. Facilitates organisational compliance with industry-specific requirements (such as GDPR, HIPAA, etc.) by the implementation of mandated security measures and processes.

### **Encouraging Security-by-Design Principles:**

Promote the integration of security considerations during the design and development stages of IoT applications. Additionally, it promotes a proactive stance towards security, guaranteeing that security measures are built into IoT systems from the beginning, hence reducing vulnerabilities.

### **Improving Trustworthiness and Dependability:**

Compliance with security standards cultivates trust among users, stakeholders, and the wider IoT community. And it exhibits dedication to security, dependability, and honesty, enhancing trust in the safety and durability of IoT systems.

### **Enabling Risk Management and Resilience:**

Standards offer structures for evaluating, controlling, and preparing for unexpected events in IoT settings. In addition, facilitates organisations in effectively recognising, evaluating, and minimising potential security hazards, hence improving the overall robustness of IoT systems.

### **Promoting Industry Collaboration and Innovation:**

It provides facilitate cooperation among stakeholders in the industry, stimulating innovation and the exchange of information in IoT security. The facilitates the advancement of IoT security in the industry by fostering the development of shared security practices, technology, and solutions.

### **Ensuring Long-Term Sustainability:**

By implementing security standards, it is guaranteed that IoT applications can withstand and adapt to emerging threats, ensuring their long-term viability and enhances the security of IoT systems, enabling them to effectively handle new security problems and technological breakthroughs. Adhering to established security standards within IoT applications is fundamental in addressing vulnerabilities, protecting data, ensuring compliance, and fostering a secure and trustworthy IoT ecosystem.

In conclusion, with and applications of mentioned solutions, it can be summarize with this points to enhance security in next-generation IoT applications, it is necessary to tackle a range of difficulties by implementing targeted solutions:

- Implement multifactor authentication and strong access control techniques to authenticate devices and control access.
- Utilise robust encryption mechanisms and secure channels to safeguard data during transmission.
- Guarantee the integrity of firmware and software by using secure boot and code signing procedures.
- Implement Security by Design: Incorporate security functionalities into IoT devices throughout the design stage, adhering to secure development methodologies.
- Utilise AI-powered analytics to identify anomalous behaviours across IoT networks, facilitating swift discovery of potential threats.
- Implement continuous monitoring by leveraging SIEM systems to actively monitor in real-time and build comprehensive incident response strategies.
- Ensure conformity with IoT security standards and regulatory mandates regarding data privacy and security.
- Supply Chain Security: Evaluate vulnerabilities in the Internet of Things (IoT) supply chain and guarantee the procurement of components with robust security measures.
- Utilise blockchain technology to provide secure storage of data and maintain transactional integrity.

- Enhance education and raise awareness on IoT security, while also offering comprehensive training on optimal strategies.
- Promote industry collaboration and facilitate the exchange of information on security threats.
- Create flexible security solutions that can be adjusted to suit various IoT ecosystems and upcoming developments.
- By using these solutions, the security of IoT applications is improved, reducing vulnerabilities and establishing a strong and secure IoT environment.

### References

- [1] V. Miori and D. Russo, "Improving life quality for the elderly through the social Internet of Things (SIoT)", *Proc. Global Internet of Things Summit (GIoTS)*, pp. 1-6, 2017.
- [2] Security-Aware Provenance for Transparency in IoT Data Propagation
- [3] G. Hernandez, O. Arias, D. Buentello, and Y. Jin, "Smart nest thermostat: A smart spy in your home," Black Hat USA, pp. 1
- [4] S. Zonouz, J. Rrushi, and S. McLaughlin, "Detecting industrial control malware using automated plc code analytics," *IEEE Security & Privacy*, vol. 12, no. 6, pp. 40–47, 2014.
- [5] P. Voigt and A. Von dem Bussche, "The eu general data protection regulation (gdpr)," *A Practical Guide*, 1st Ed., Cham: Springer International Publishing, 2017.
- [6] P. F. Edemekong and M. J. Haydel, "Health insurance portability and accountability act (hipaa)," in *StatPearls [Internet]*. StatPearls Publishing, 2019.
- [7] D. Puthal, S. Nepal, R. Ranjan, and J. Chen, "Threats to networking cloud and edge datacenters in the internet of things," *IEEE Cloud Computing*, vol. 3, no. 3, pp. 64–71, 2016
- [8] K. Hamlen, M. Kantarcioglu, L. Khan, and B. Thuraisingham, "Security issues for cloud computing," *International Journal of Information Security and Privacy (IJISP)*, vol. 4, no. 2, pp. 36–48, 2010
- [9] O. Arias, J. Wurm, K. Hoang, and Y. Jin, "Privacy and security in internet of things and wearable devices," *IEEE Transactions on MultiScale Computing Systems*, vol. 1, no. 2, pp. 99–109, 2015.
- [10] B. J. Mohd, T. Hayajneh, and A. V. Vasilakos, "A survey on lightweight block ciphers for low-resource devices: Comparative study and open issues," *Journal of Network and Computer Applications*, vol. 58, pp. 73–93, 2015.
- [11] A. Moradi, A. Poschmann, S. Ling, C. Paar, and H. Wang, "Pushing the limits: a very compact and a threshold implementation of aes," in *Annual International Conference on the Theory and Applications of Cryptographic Techniques*. Springer, 2011, pp. 69–88.
- [12] A. Seshadri, A. Perrig, L. Van Doorn, and P. Khosla, "Swatt: Softwarebased attestation for embedded devices," in *IEEE Symposium on Security and Privacy, 2004. Proceedings. 2004. IEEE, 2004*, pp. 272–282.
- [13] A. Seshadri, M. Luk, E. Shi, A. Perrig, L. Van Doorn, and P. Khosla, "Pioneer: verifying code integrity and enforcing untampered code execution on legacy systems," in *ACM SIGOPS Operating Systems Review*, vol. 39, no. 5. ACM, 2005, pp. 1–16.
- [14] A. Seshadri, M. Luk, A. Perrig, L. van Doorn, and P. Khosla, "Scuba: Secure code update by attestation in sensor networks," in *Proceedings of the 5th ACM workshop on Wireless security*. ACM, 2006, pp. 85–94.
- [15] T. Abera, N. Asokan, L. Davi, F. Koushanfar, A. Paverd, A.-R. Sadeghi, and G. Tsudik, "Things, trouble, trust: on building trust in iot systems," in *Proceedings of the 53rd Annual Design Automation Conference*. ACM, 2016, p. 121.
- [16] C. Su, B. Santoso, Y. Li, R. H. Deng, and X. Huang, "Universally composable rfid mutual authentication," *IEEE Transactions on Dependable and Secure Computing*, vol. 14, no. 1, pp. 83–94, 2017.

- [17] C.-I. Fan, S.-Y. Huang, and Y.-L. Lai, "Privacy-enhanced data aggregation scheme against internal attackers in smart grid," *IEEE Transactions on Industrial informatics*, vol. 10, no. 1, pp. 666–675, 2013.
- [18] S. Zawoad and R. Hasan, "Faiot: Towards building a forensics aware eco system for the internet of things," in *2015 IEEE International Conference on Services Computing*. IEEE, 2015, pp. 279–284.
- [19] C. Koliass, A. Stavrou, J. Voas, I. Bojanova and R. Kühn, "Learning Internet-of-Things Security "Hands-On"".
- [20] U. Tariq, I. Ahmed, A. K. Bashir and K. Shaukat, "A Critical Cybersecurity Analysis and Future Research Directions for the Internet of Things: A Comprehensive Review".



### PHOTOVOLTAICS ENERGY CONTRIBUTION AND THEIR IMPACT ON CARBON EMISSIONS REDUCTION IN TÜRKİYE

Assist. Prof. Dr. Derya Betül UNSAL

<sup>1</sup> Energy and Technology Engineering Department, Sivas Cumhuriyet University

<sup>2</sup> Renewable Energy Research Center, Sivas Cumhuriyet University

#### ABSTRACT

The significant influence of anthropogenic greenhouse gas emissions, particularly carbon, on the initiation of climate change cannot be overstated. In order to tackle this matter, Türkiye's first energy efficiency action plan, the National Energy Efficiency Action Plan (NEEAP) (2017-2023) aims 14 per cent decrease in Türkiye's primary energy consumption in 2023. One potential strategy for mitigating carbon emissions involves the substitution of renewable energy sources for fossil fuel-based electricity production. A domestic solar panel system possesses the capacity to fulfil the electrical requirements of a complete campus while exhibiting around 80% reduced carbon emissions in comparison to fossil fuels. I conducted an investigation on household solar systems in Sivas Cumhuriyet University and assessed their capacity to contribute towards NEEAP objective. The objectives of this study were to ascertain the proportion of campus buildings that have presently adopted solar energy systems and to quantify the corresponding reduction in carbon emissions. Additionally, the aim was to determine the percentage of households that would need to adopt solar energy in order for Sivas to achieve a substantial mitigation of carbon emissions relative to the current baseline. Lastly, the study sought to identify specific groups of buildings that should be prioritised in government policies aimed at mitigating emissions. According to my findings, the present adoption rate of solar systems in Sivas Cumhuriyet University Campus is at 0.9%. However, to achieve a substantial reduction in carbon emissions by the year 2033, it is imperative that a minimum of 60% of residential properties in the state embrace solar installations. The primary impediment to the widespread adoption of solar energy is its high cost. Consequently, in order to achieve a 60% installation rate of solar systems in residential properties, it is imperative for the government to establish and improve subsidy and feed-in tariff initiatives. However, it is imperative to acknowledge that achieving the NEEAP necessitates a broader examination of emissions sources beyond solely concentrating on electricity generation.

**Keywords:** Renewable energy; solar energy; Türkiye; University Campus Buildings

#### 1. Introduction

The integration of photovoltaics is crucial in mitigating carbon emissions and tackling the environmental issues linked to conventional energy sources. Amidst the global shift towards cleaner and more sustainable energy options, the deployment of solar systems has garnered considerable interest. These systems are specifically engineered to use solar energy and transform it into electrical power, providing a feasible substitute for conventional energy sources that contribute to the release of greenhouse gases and damage of the environment. Photovoltaic technologies can be categorised into distinct groups, including wafer-based and thin-film cells, each possessing its own distinctive features and advantages. The extensive implementation of these technologies holds the capacity to diminish carbon footprints, alleviate the consequences of global warming and climate change, and foster a healthier and more sustainable environment on a local, national, and worldwide scale. [1-3]

Currently, the primary source of electricity production is derived from fossil fuels. Oil, coal, and natural gas are the prevailing fossil fuels, notorious for inflicting significant harm to the environment and projected to deplete in the future. The demand for carbon emissions reduction has led to a growing reliance on renewable energy sources as a result of limited reserves. Several states are actively working to reduce their reliance on fossil fuels by promoting the use of renewable energy sources for electricity generation. Türkiye possesses



significant potential for renewable energy sources, particularly solar energy, as depicted in Figure 1. Moreover, our government provides substantial support for the development of renewable energy sources (RES). Solar energy, being a widely utilised renewable energy source, is a significant contributor to our energy supply, second only to wind power, which plays a crucial role in decreasing our reliance on fossil fuels [2].

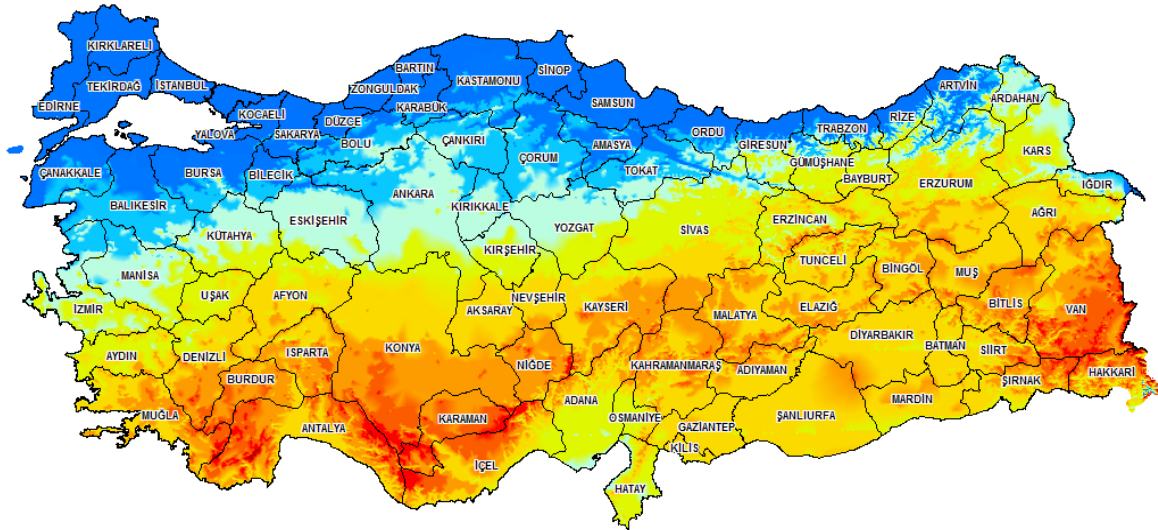

**Figure 1.** Photovoltaic power potential in Türkiye

Global energy-related CO<sub>2</sub> emissions grew by 0.9% or 321 Mt in 2022, reaching a new high of over 36.8 Gt. Following two years of exceptional oscillations in energy use and emissions, caused in part by the Covid-19 pandemic, last year's growth was much slower than 2021's rebound of more than 6%. Emissions from energy combustion increased by 423 Mt, while emissions from industrial processes decreased by 102 Mt [4].

Although electricity generation from a solar PV system has almost zero emissions during its lifespan of 25–30 years, the manufacturing and installation of solar PV systems require energy/material inputs and produce emissions. As it can be shown in Figure 2. over the years, solar power in Türkiye continues to grow, as demonstrated by its built-in power. While replacing fossil fuels with renewable energy, such as solar photovoltaic (PV) energy is the key to electric sector decarbonization.

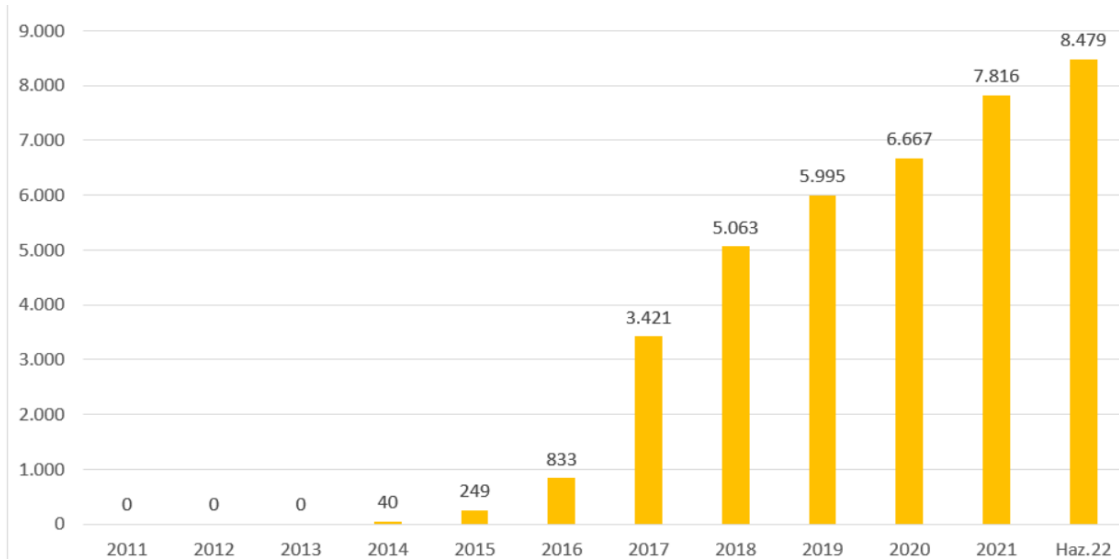

**Figure 2.** Türkiye's solar current installed power as of June 2022 [5].

In addition to the economic and financial implications of this progress, the contribution to sustainability is a very important issue. Each installed solar panel contributes to a certain amount of carbon emissions. Generally, carbon emissions can be defined in form as explained below.

Carbon emissions, also known as greenhouse gas emissions, mostly arise from the combustion of fossil fuels such as coal, oil, and gas. Upon combustion of these fuels for energy generation, carbon dioxide, methane, and nitrous oxide (N<sub>2</sub>O) are emitted into the atmosphere. The gases in question have the ability to capture and retain the heat emitted by the Earth, resulting in a phenomenon known as the "greenhouse effect." This, in turn, contributes to the occurrence of global warming and climate change. Carbon emissions are commonly quantified in metric tonnes of CO<sub>2</sub> equivalent, which considers the varying global warming potentials of greenhouse gases [6].

Primary contributors to carbon emissions encompass energy generation, forest depletion, transportation, and industrial activities. The escalating carbon emissions are a significant factor in the elevation of global temperatures, resulting in consequences such as the melting of ice caps, the rise in sea levels, and the occurrence of extreme weather events. Minimising carbon emissions is crucial for decelerating the rate of climate change. This can be accomplished by transitioning to renewable energy sources, implementing energy efficiency measures, undertaking reforestation initiatives, and modifying consumption patterns. Installing photovoltaics is an effective way to reduce dependence on fossil fuels and thereby minimise carbon emissions [7].

An important benefit of solar installation is its capacity to generate electricity without emitting greenhouse gases. Utilising solar electricity greatly diminishes the dependence on fossil fuels, which are the principal culprits behind carbon emissions. With the increasing adoption of solar energy by businesses and homes, there is a significant reduction in the overall carbon footprint, resulting in a beneficial effect on the environment [8].

## 2. Material and Methods

The study assessed the carbon dioxide emissions generated by the 2MW solar panel that is scheduled for installation on the university premises. It thoroughly examined the long-term consequences of these emissions. As per the rectorate of Sivas Cumhuriyet University (SCU), the proposed establishment of a solar power facility on the main campus, which consumes over 21 MW of electricity each month, is projected to significantly decrease carbon emissions on an annual basis. The objective of the study is to offer recommendations for the construction of larger solar panels at the SCU in the near future. As each MW solar panel generates the same amount of carbon emissions, the carbon emission data for the region remains consistent over time and is unaffected by meteorological conditions. The meteorological data used for Sivas are shown below in Figure 3. The meteorological data used for solar panel power generation are from the official website of the General Directorate of Meteorology and also, calculation serves as the foundation for future work in this particular environment.

Extreme Maximum, Minimum and Average Temperatures Measured in Long Period (°C)												
SIVAS	January	February	March	April	May	June	July	August	September	October	November	December
Maximum Temp.	18.6	18.1	25.2	29.0	33.5	35.5	40.0	39.9	37.0	30.5	24.0	19.4
Minimum Temp.	-31.2	-34.4	-27.6	-11.0	-5.5	-0.6	3.0	3.2	-3.8	-9.0	-24.4	-30.2
Average Temp.	-2.7	-1.6	3.8	9.3	13.7	17.7	20.8	21.1	17.0	11.6	4.7	-0.2
Average Max. Temp.	1.7	3.5	9.5	15.9	20.7	25.1	29.0	29.7	25.5	19.3	11.1	4.2
Average Min. Temp.	-6.2	-5.7	-0.9	3.7	7.6	10.8	13.2	13.3	9.5	5.3	-0.3	-3.7

**Figure 3.** Meteorological data for Sivas City Centre.

This will guarantee the quantification of CO<sub>2</sub> emissions per MW of solar panels to be constructed, and will also serve as the foundation for future expansions in solar panel capacity. And the city of Sivas which placed in Sivas Cumhuriyet University, is one of the cities with the highest rates of sun potentials in Türkiye.

The formulas used in the calculation of carbon emissions are calculated using the following equations in the MATLAB software. The quantification of carbon emissions reduction resulting from the utilisation of solar photovoltaic technology can be obtained by analysing both direct and indirect data sources. The direct data pertains to the power produced by the solar PV systems, while the indirect data refers to the emissions factor of the grid on which the solar PV system is located.

The planning for the construction of a solar panel within the SCU settlement has been completed, using the relevant data for the calculation.

The planning incorporates the following materials:

- Matlab calculation software,
- Meteorological data for the Central District of Sivas Province,
- Coordinates provided by of the Department of Construction at SCU,
- A settlement map.

The formula commonly employed with the amount of CO<sub>2</sub> saved per year (in tonnes) can be calculated by multiplying the electricity generated by the PV system per year (in kWh) by the emissions factor (in tonnes of CO<sub>2</sub> per kWh).

The equation for CO<sub>2</sub> emissions can be represented as:

$$CO_2 \text{ Emissions} = \sum(EmissionsStage \times QuantityStage)$$

- Emissions Stage = Emissions per unit (kg CO<sub>2</sub> per unit) for each life cycle stage (manufacturing, transportation, installation, etc.).
- Quantity Stage = Quantity of PV modules or components used in each stage.

The power produced by the PV system can be readily acquired from the system's data, however the emissions component typically requires obtaining information from local or national energy authorities, as it fluctuates based on the fuel composition of the local energy grid. It is crucial to remember that the measurement in question pertains to the decrease in emissions relative to an alternative scenario, typically involving grid electricity, rather than the complete avoidance of emissions. According to Figure 4. In 2022, global energy-related carbon dioxide (CO<sub>2</sub>) emissions increased by 0.9%, equivalent to 321 million metric tonnes, resulting in a record-breaking total of more than 36.8 billion metric tonnes. After experiencing significant fluctuations in energy consumption and emissions over the past two years, largely due to the impact of the Covid-19 epidemic, the growth rate in the previous year was considerably slower compared to the robust rebound of over 6% saw in 2021. The emissions resulting from the combustion of energy sources experienced a rise of 423 million metric tonnes, whilst emissions stemming from industrial activities witnessed a decline of 102 million metric tonnes.

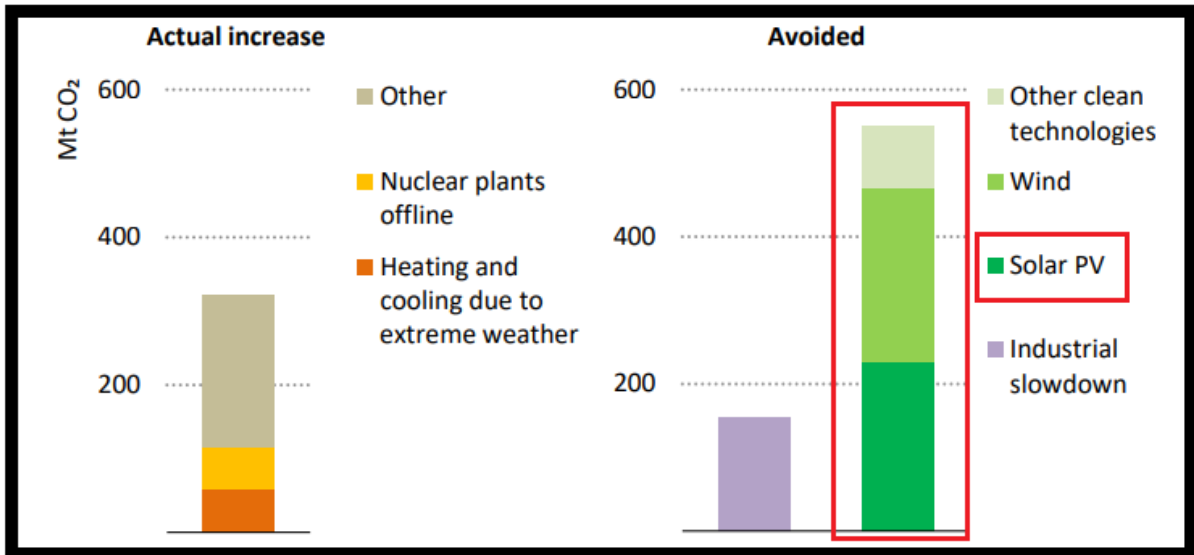

**Figure 4.** Co2 Emissions changing during 2021 between 2022 in the World. [4]

The goal of the Türkiye’s Energy action plan for the years 2017–2023 is to use 55 measures divided into 6 categories—buildings and services, energy, transportation, industry and technology, agriculture, and cross-cutting (horizontal) areas—to lower Türkiye's main energy consumption by 14% by 2023. Additionally, by 2023, it is anticipated to save 23.9 mtoe cumulatively, for which 10.9 billion USD would be invested. At 2017 pricing, the total savings by 2033 will be 30.2 billion USD, and some savings will still have an impact in 2040 [5]. A typical action's payback time is seven years. A total of 4.149 million USD was spent in energy efficiency between 2017 and 2019, translating into 2,744 ktoe of energy savings, or 960 million USD in monetary equivalent.

### 3. Results

The calculations made using the equations and data mentioned earlier in this study are given in detail in the Table I below. The calculations have been completed with the data obtained from the Department of Construction of SCU where has an annual electricity consumption capacity of 21.415.058 (Kwh). It is very important that consumption-oriented production can be achieved in order to demand-demand balance. The solar panel, which is planned to be installed within the University's campus, which produces approximately 25.250 tCo<sub>2</sub> annually, could produce 3.587.20 MWh of energy. With an area of 19,430 m<sup>2</sup>, the central campus has been planned to be installed in the form of 5,760 pieces of 450 Wp panels and 20 pieces of 100 kW inverters. Together with these calculations, the 2 MW Solar Panel will reduce annual carbon emissions by 2.325,22 tCO<sub>2</sub> and reduce electricity bills by 3,587,200 kWh. Under this scope, the relevant electricity consumption will be reduced to 17.9 million. Further expansion of the pv plants in the future study could result in zeroing the campus's electricity bill.

**Table I.** Calculation Results.

<b>INFORMATION REGARDING THE ELECTRICITY CONSUMPTION OF SIVAS CUMHURİYET UNIVERSITY</b>	
ELECTRICITY CONSUMPTION (kWh/y)	21.415.058 (2022)
CONTRACTUAL CAPACITY (kW)	2.000
CAPACITY OF THE NEW PLANT (kWe / kWp)	2.000,00 / 2.593,00
<b>THE UNIVERSITY CAMPUS INFORMATION</b>	
ROOF AREA (m <sup>2</sup> )	19.430
PROVINCE, DISTRICT, QUARTER	Sivas Province, Central District, Kayseri street.
BLOCK, PLOT, LAYOUT NR OF LAND	Block: 5443 Plot:8,9
LAND OWNERSHIP – RIGHT OF USE	University
<b>INFORMATION REGARDING THE PLANNED PLANT</b>	
NUMBERS - CAPACITY OF PANELS	5.760 pieces of 450 Wp panel
NUMBER OF INVERTERS	20 pieces of 100 kW inverters
ASSEMBLY TYPE	Land
<b>CONNECTION TO THE GRID</b>	
TRANSFORMER INFORMATION (NEW NEED)	72 KV 1.250 MVA or 36KV 2500MVA
ENERGY TRANSMISSION LINE TYPE	8 X (1X95 mm <sup>2</sup> ) XLPE Cable
DDISTANCE TO TRANSFORMER	Insite
<b>ECONOMIC ACHIEVEMENTS</b>	
ANNUAL ELECTRICITY PRODUCTION	3.587,20 MWh
CO <sub>2</sub> EMISSION REDUCTION	2.325,22 tCO <sub>2</sub> /year

#### 4. Conclusion

PV installation not only provides environmental benefits but also aids to the mitigation of air pollution. Conventional energy sources, including coal and natural gas, not only discharge carbon dioxide but also produce detrimental pollutants such as sulphur dioxide, nitrogen oxides, and particulate matter. Through the utilisation of solar energy, we can reduce the emission of these harmful substances, consequently enhancing the quality of air and promoting public health.

The study calculated the impact of the CO<sub>2</sub> emission of the 2MW solar panel, which is planned to be installed within the university, and studied its long-term effects in detail. According to information from the rectorate of Sivas Cumhuriyet University, the planned solar power plant, which consumes about 21 MW of power per month, is estimated to reduce carbon emissions by 2.325,22 tCO<sub>2</sub> per year.

According to the official information data, the present adoption rate of solar systems in Sivas Cumhuriyet University Campus is at 0.9%. However, to achieve a substantial reduction in carbon emissions by the year 2033, it is imperative that a minimum of 60% of residential properties in the state embrace solar installations. The primary impediment to the widespread adoption of solar energy is its high cost. With the integration of 2MW solar panels, the rate would have risen to about 10.9%.

The aim of the study is to provide guidance for larger solar panels that could be built within the University of SCU in the coming years. Since each MW solar panel produces equal carbon emissions, the carbon emission data for the region is stable over the years and meteorological data. In this context, calculation forms the basis for future work.

Moreover, the extensive implementation of photovoltaic (PV) installation promotes technological progress and innovation in the renewable energy industry, resulting in enhancements in solar efficiency and cost-efficiency. This facilitates the development of a more sustainable and robust energy infrastructure, especially in areas with limited access to dependable electricity. Given the increasing need for environmentally friendly and sustainable energy sources, it is crucial for governments and organisations to provide backing and offer incentives for the implementation of solar systems. Government measures can expedite the adoption of solar energy, thereby enhancing efforts to decrease carbon emissions and maintain ecological equilibrium. In general, the incorporation of photovoltaics into the power grid has a substantial impact on decreasing carbon emissions and advancing environmental sustainability. Ultimately, the implementation of solar systems has a pivotal impact on mitigating the rate of carbon emissions at regional, national, and global scales. It aids in mitigating climate change by diminishing dependence on fossil fuels, minimising air pollution, fostering technological innovations in renewable energy, and advocating for a healthier and more sustainable future for consumers of electrical energy.

### References

- [1] M. Hosenuzzaman, N. Rahim, J. Selvaraj, M. Hasanuzzaman, A. Malek and A. Nahar. "Global prospects, progress, policies, and environmental impact of solar photovoltaic power generation". *Renewable & Sustainable Energy Reviews*. vol. 41. pp. 284-297. Jan. 2015. 10.1016/j.rser.2014.08.046.
- [2] M. K. H. Rabaia et al.. "Environmental impacts of solar energy systems: A review". *Science of The Total Environment*. vol. 754. pp. 141989-141989. Feb. 2021. 10.1016/j.scitotenv.2020.141989.
- [3] L. O. Herwig. "Impacts of global electrification based upon photovoltaic technologies". *Renewable Energy*. vol. 10. no. 2-3. pp. 139-143. Feb. 1997. 10.1016/0960-1481(96)00052-3.
- [4] <https://www.iea.org/reports/co2-emissions-in-2022>.
- [5] <https://www.enerji.gov.tr>
- [6] Y. Wang. "Solar Photovoltaic Power Generation Technology Research". *IOP Conference Series: Materials Science and Engineering*. vol. 677. no. 3. pp. 032039-032039. Dec. 2019. 10.1088/1757-899x/677/3/032039.
- [7] W. S. Ebhota and T. Jen. "Photovoltaic Solar Energy: Potentials and Outlooks". Nov. 2018. 10.1115/imece2018-86991.
- [8] F. Hussin, G. Issabayeva and M. K. Aroua. "Solar photovoltaic applications: opportunities and challenges". *Reviews in Chemical Engineering*. vol. 34. no. 4. pp. 503-528. May. 2017. 10.1515/revce-2016-0058.

### ATIK BITKİSEL YAĞLARDAN BİYODİZEL ELDESİNİN DEĞERLENDİRİLMESİ

#### EVALUATION OF BIODIESEL OBTAINING FROM WASTE VEGETABLE OILS

**Meltem Sarıoğlu Cebeci**

Sivas Cumhuriyet Üniversitesi, Çevre Müh Bölümü, Sivas

#### ÖZET

Fosil yakıtların başta sera gazı oluşuma yani atmosferde özellikle metan ve karbondioksit gazının artışına neden olarak küresel ısınmaya yani iklim değişikliğine neden olduğu bilinmektedir. Ayrıca fosil yakıtların rezervleri azalmakta öte yandan nüfus artışı ile birlikte sanayileşme hızla artmaktadır. Bu nedenlerle alternatif enerji kaynaklarına olan ihtiyaç ve önem gerek dünyada gerekse Ülkemizde gittikçe artmaktadır.

Çağımızın en büyük sorunu olan küresel ısınma ve iklim değişikliğinde büyük rol oynayan fosil yakıtların yerine biyodizel gibi çevreci bir alternatif bulunması oldukça önemlidir. Biyodizel eldesi genellikle bitkisel ve hayvansal yağlardan yapılmaktadır. Alıcı ortama verildiğinde su kaynaklarına ciddi zarar veren atık yağların, biyodizel üretiminde kullanılarak ekonomiye kazandırılması hem kalkınma hem de çevresel sürdürülebilirlik açısından önemli bir adımdır. Bu çalışmada atık kızartma yağı ve rafine edilmemiş ayçiçek yağından transesterifikasyon yöntemi kullanılarak biyodizel elde edilmiştir. Elde edilen biyodizellerin kinematik viskozitesileri ve yoğunlukları literatüre benzer değerler bulunmuştur. Üretilen biyodizelin motorlarda yakıt olarak yakılmasıyla performans testleri yapılabilmektedir.

#### ABSTRACT

The reason of global warming is mainly fossil fuels . Increase of methane and carbon dioxide gas in the atmosphere cause to climate change. In addition, because of population and industrial technological developments, fossil fuel reserves are decreasing recently. For these reasons, needing and urgent of alternative energy sources is increasing both in all over the world and in Turkey.

An environmentally friendly alternative such as biodiesel instead of fossil fuels are very important to decrease the global warming and climate change. They are the major problems of our century. Generally vegetable and animal oils can be used for biodiesel production. Use of waste oils is very important point in order to protect receiving water and environment for both waste management and environmental sustainability. Otherwise waste oil cause serious harmful effects to water resources and environment In this study, transesterification method was used to produce biodiesel using waste frying vegetable oil and unrefined sunflower oil . The kinematic viscosities and densities of the obtained biodiesels were found to be similar to the literature. Performance tests can be considered by using this biodiesel in engines.

#### 1.INTRODUCTION

The reason of global warming is mainly fossil fuels . Increase of methane and carbon dioxide gas in the atmosphere cause to climate change. In addition, because of population and industrial technological developments, fossil fuel reserves are decreasing recently. For these reasons, needing and urgent of alternative energy sources is increasing both in all over the world and in Turkey.

Due to reasons such as the energy need arising from population growth and technological developments, the gradual reduce in oil sources, increasing oil prices and the environmental effects of fossil fuel, most of the researchers have started to investigate several alternative energy sources. Biodiesel is preferred as an alternative due to renewable and it contains less hydrocarbon (HC), carbon monoxide (CO), sulfur dioxide (SO<sub>2</sub>), mercury (Hg) and particles in emissions compared to fossil fuels. In addition, if produced on a large scale, biodiesel will be preferred because it will reduce the demand for fossil fuels, reduce fossil fuel prices, and create a new market for agricultural raw materials (Aksoy, 2010). Except fuel renewable energy source alternatively should be economic, environmentally friendly, easy available called biodiesel obtained from

plant derived such as vegetable oils. Some researchers have shown that biodiesel has several advantages compared to petroleum-based diesel. Biodiesel is renewable, biodegradable, non-toxic, miscible with petrodiesel, has intrinsic lubricity, has no aromatic and sulfur content and has very low emission level. The use of biodiesel will be very attractive alternative for the agriculture, economic development and the environment (Kaya, 2006; Torres et al., 2013). Biofuels are produced from biological sources. In general, biofuels can be usually divided into two groups : first-generation or conventional fuels produced from vegetable oil, sugar and starch and second-generation fuels. First generation fuels or conventional biofuels are generally obtained from a source of sugar, starch and vegetable oil. In contrast, second-generation biofuels are sustainable feedstocks (Gnanaprakasam et al., 2013).

Vegetable or animal oils are used to produce biodiesel. Most of the world's energy needs are met by petrochemical resources, coal, natural gas, hydroelectric and nuclear energy. Except for hydroelectric and nuclear energy, all these resources are finite and will be exhausted in a short time at the current rate of use. Diesel fuels have an important place in the industrial economy of a developing country. It is used to transport industrial and agricultural goods and to operate diesel tractors and pump sets in the agricultural sector. Due to its highly viscous nature, vegetable oil has been limited as a fuel in direct application compression ignition engines (Gupta et al., 2007; Tshizanga et al., 2017 ). It is possible to reduce its viscosity by: converting vegetable oil into alkyl esters using the transesterification reaction (Alamu et al., 2008; Fariku et al., 2007; Connemann and Fischer, 1998). Today, biodiesel production has increased greatly to compete with fossil fuels. Biofuels are mostly derived from cooking oil, inedible oils, fats, waste cooking oils and algae. The advantage of using crude vegetable oil (edible oil) as raw material for biodiesel production is its low free fatty acid content (Ullah et al., 2009). Similarly, the main advantage of biodiesel synthesis, an inedible oil source, is due to its high free fatty acid content (Diwani et al., 2009). Instead of using pure vegetable oil, waste cooking oil can be used as feedstock for biodiesel production (Canakci, 2007; Gnanaprakasam et al., 2013). Biodiesel is generally made from vegetable oils (canola, safflower, soybean, cotton, sunflower, linseed, peanut, finished oil), as well as vegetable waste oils (domestic waste oil, industrial waste oil, waste oils from consumption) and animal oils (fish oil, It is the name given to diesel vehicle fuel produced by transesterification method (such as chicken fat). Briefly, the first diesel engine produced by Rudolf Diesel was powered by vegetable oil. It was previously used as lamp oil (Kaya, 2006).

Positive some properties of biodiesel: It is an alternative energy source. It allows the evaluation of used oils such as domestic oils. Glycerin is obtained for commercial purposes as a by-product. It is environmentally friendly and does not harm the environment, because it has no toxic effects and is biodegradable in nature and environmentally friendly and does not harm the environment, because it has no toxic effects and is biodegradable in nature. Its some negative features are: Carbon accumulation. Reduces the lifespan of vehicle engines; because its fat content is high and its iodine count is quite low. High viscosity (approximately 11-17 times higher than Diesel fuel), low volatility and improper evaporation properties that cause deposits in engines resulting from insufficient combustion. Modified engines are made by Elsbett in Germany and Malaysia, and by Diesel Morten und Geraetebau GmbH (DMS) in Germany and the USA, and these engines show good performance when operated with plant oils of different composition and grade (Raymond et al., 2004; Kaya, 2006).

In this study, biodiesel was obtained from waste frying oil and unrefined sunflower oil using the transesterification method. The kinematic viscosities and densities of the obtained biodiesels were found to be similar to the literature.

## 2. BIODIESEL PRODUCTION

Many studies have been carried out so far to obtain fuel from vegetable oils with approximately the properties and performance of hydrocarbon-based diesel fuel. There are four most used methods in order to reduce viscosity (Arslan and Alibaş, 2019; Demir, 2006; Aktaş et al., 2020). These are Pyrolysis, Dilution, Microemulsification and Transesterification. As of 2015, the Super Critical production method has been added to these known methods. Scientific and technological developments show that it is possible to develop new methods in the coming years (Arslan and Alibaş, 2015).



### 3. Comparison of Biodiesel Production Technologies

*Dilution method:* It is the process of diluting vegetable and waste oils by mixing them with a solvent or diesel fuel in certain proportions. (Tippayawongvd., 2012). Oils used in the dilution method of biodiesel production; peanut oil, rapeseed oil, sunflower oil and waste oils (Eryılmaz, 2014).

*Microemulsion formation method:* Microemulsion is a colloidal solution formed between two immiscible liquids and ionic or non-ionic organic mixtures (1-150 nm in size). It is possible to produce alternative diesel fuels with this method. The organic substances used in this method are short-chain aliphatic alcohols (MeOH, EtOH) (Archarya et al., 2016).

*Pyrolysis method:* Generally, pyrolysis is done in two ways. In the first method, vegetable oils are broken down by heat in a closed container. In the second method, vegetable and waste oils are thermally broken down by distillation using standard prepared substances. Biodiesel obtained with the second method shows properties closer to diesel fuels (Zhengi et al., 2004).

*Transesterification method:* It is the formation of biodiesel as a result of the reaction of animal and vegetable oils with short-chain alcohols. Generally, MeOH and EtOH are used. The transesterification method was mentioned in detail above (Chee Loong and Idris, 2014; Özdemir and Mutlubaş, 2016, Amenaghawon et al., 2021).

### 4. MATERIALS AND METHOD

#### - \*Transesterification Method

It is the esterification reaction of fatty acids (vegetable oils, domestic waste oils, animal fats) with alcohol (methanol, ethanol, etc.) in the presence of a basic catalyst. The following process steps occur in biodiesel production with this method:

**Mixing alcohol and catalyst:** The catalyst is typically sodium hydroxide (caustic soda) or potassium hydroxide. The catalyst is dissolved in alcohol using a standard stirrer and mixer. High levels of free fatty acid or water may cause problems with soap formation and downstream separation of the glycerin byproduct.

**Separation:** After the reaction is completed, the two main products are glycerin and biodiesel. Each contains a significant amount of methanol left over from the amount used in the reaction. A centrifuge is used to separate these two materials faster.

**Removal of alcohol:** After the glycerin and biodiesel phases are separated, excess alcohol in each phase is removed by a flash evaporation or distillation process and the reaction mixture is neutralized.

**Glycerin neutralization:** The glycerin by-product contains unused catalyst and soaps neutralized with an acid and is sent to the storage tank to be stored as crude glycerin. Water and alcohol are removed to obtain glycerin of 80-88% purity, ready for sale as crude glycerin. It is distilled to higher purity and sold to the cosmetics and pharmaceutical industry.

**Methyl ester washing process:** After being separated from glycerin, biodiesel is washed slowly with warm water to remove residual catalyst and soaps, the water is removed and sent to storage.

#### \* Production of Biodiesel

The transesterification method was chosen to convert crude oils and waste oils into biodiesel. To obtain higher efficiency, the vegetable oil alcohol molar ratio was taken as 1:6 instead of 1:3. 300 g of vegetable oil, 60 g of CH<sub>3</sub>OH (approximately 1:6 molar ratio) and 1.5 g of NaOH (sodium methoxide was used for vegetable oil) were mixed under reflux at 60-70°C. When a glycerin layer formed at the bottom of the reaction vessel (after approximately 2-2.5 hours), the mixture was placed in a 54 separating funnel. After waiting overnight, two phases were obtained. The lower phase was taken as glycerin and centrifuged, and the upper phase (methyl ester phase) was washed with hot water until neutralized and dried in a vacuum desiccator, then two phases were obtained. The lower phase was taken as glycerin and centrifuged, and the upper phase (methyl ester phase) was washed with hot water until neutralized and dried in a vacuum desiccator.

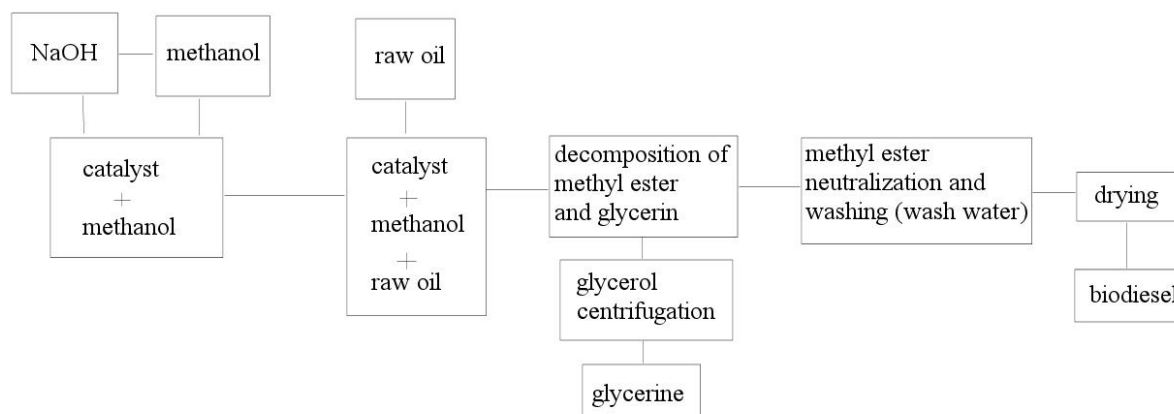

**Figure 1.** General biodiesel production scheme

To convert waste oils into biodiesel, a filtering process was performed to remove foreign substances before the transesterification process. In addition, both NaOH and KOH catalysts were studied separately in waste oils and the effect of the catalyst was examined.

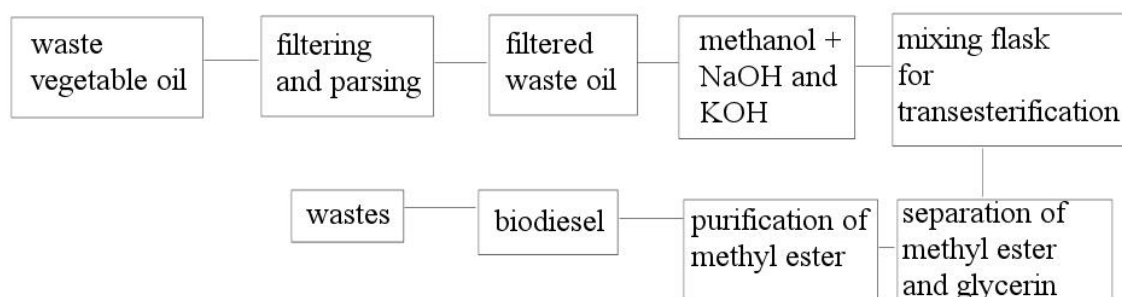

**Figure 2.** Obtaining biodiesel from waste oils

### Viscosity Test

Viscosity is defined as the resistance of a flowing liquid to flow. As the chain length of hydrocarbons increases, viscosity increases, and as the number of double bonds increases, viscosity decreases. Silt and oxidation products of biodiesel increase viscosity. The kinematic viscosities of waste oils and biodiesels were measured at 40 °C with the Viscosity Bath device. Flow times were determined with a stopwatch. Viscosities were calculated from flow times.

$$\text{Viscosity} = C * t$$

C: Viscometer constant (Written on each viscometer tube)

t: Flow time (seconds)

It was calculated using the equation.

## 5. FINDINGS

The density of biodiesel (860-900 kg/m<sup>3</sup>, 15°C, EN1424) is higher than fossil diesel fuel (820-845 kg/m<sup>3</sup>, EN 590). Density affects fuel consumption and combustion heat. As the hydrocarbon chain lengthens, the density decreases, and as the number of double bonds increases, the density increases.

In this study, biodiesels were produced from waste frying oil and unrefined sunflower oil using the transesterification method. The kinematic viscosity and specific gravity values of biodiesels produced from waste frying oil and sunflower oil were tested. The kinematic viscosity of biodiesels obtained from waste frying oil and unrefined sunflower oil was determined as 5.54 mm<sup>2</sup>/s and 6.0 mm<sup>2</sup>/s, respectively. Specific gravity values were found to be 0.889g/cm<sup>3</sup>, 0.891g/cm<sup>3</sup>, respectively.

## 6. RESULTS AND DISCUSSION

Performance tests can be achieved by burning the produced biodiesels in engines as fuel. Because primary energy sources are limited and not environmentally friendly, renewable energy sources are needed to meet energy needs and to protect the environment. Biodiesel production is also important economically when the suitable production of biodiesel is started and continued. Since it is not a regional energy source, it can be produced in most of the place in the world. In addition, biodiesel will make a great contribution to the development of the agricultural economy and the vegetable oil industry. Biodiesel is a non-toxic energy source that can be easily biodegradable in environment without harming. Exhaust gas emission amounts of biodiesel, which contains only NO<sub>x</sub> emissions, are low. Since there is no CO<sub>2</sub> emission, it does not create a greenhouse effect. There is no need for any modification when used in diesel engines. It can also be mixed with diesel fuels in desired proportions or used in pure form. Biodiesel fuels are more stable than diesel fuels. Biodiesel fuel that has been kept too long during storage turns into an acidic structure and forms precipitates. Due to this situation, NO<sub>x</sub> emissions partially increase. In cold weather, the cloud point is low. Countries in biodiesel production should consider the growing of oilseed crops in the agricultural area.

The rapidly increasing population also increases the demand for energy. In order to meet the energy needs and achieve economic sustainability, it is very important to focus on the "Biodiesel Fuels".

## ACKNOWLEDGES

This study was supported by the Sivas Cumhuriyet University research commission with project no M-727

## REFERENCES

- Acharya, B., Guru, P. S. ve Dash, S. (2016). Tween-80-n-butanol/isobutanol-(Diesel + Kerosene)-Water microemulsions - Phase behavior and fuel applications. *Fuel*, 171, 87–93.
- Aksoy L. (2010). Alternatif Enerji Kaynağı Olarak Biyodizel ve Üretim Prosesleri. *Taşıt Teknolojileri Elektronik Dergisi*, 2(5), 45-52.
- Aktaş E.S., Demir Ö., Uçar, D. (2020). A Review Of The Biodiesel Sources And Production Methods. *International Journal of Energy and Smart Grid Vol 5, Number 1*
- Amenaghawon A.N., Evbarunegbe, N.I., Obahiagbon, K. (2021). Optimum biodiesel production from waste vegetable oil using functionalized cow horn catalyst: A comparative evaluation of some expert systems. *Cleaner Engineering and Technology*. 4 100184
- Arslan, M. ve Alibaş, K. (2015). Laboratuvar Ölçekli Biyodizel Üretim Tesisinin Projelendirilerek İmal Edilmesi ve Bu Tesiste Çeşitli Bitkisel Yağ Kaynaklarından Biyodizel Üretimi. *Uludağ Üni. Ziraat Fakültesi Dergisi*, 29(1), 107-113.
- Arslan, M. ve Alibaş, K. (2019). Uludağ Üniversitesi Gemlik Sunğipek Asım Kocabıyık Yerleşkesinin Biyodizel Potansiyelinin Belirlenmesi ve Tarım Traktöründe Kullanımı. *Tarım Makinaları Bilimi Dergisi*, 15(2), 49-52.
- Canakci, M. (2007). The potential of restaurant waste lipids as biodiesel feedstocks. *Bioresource Technology*, 98(1), 183–190.
- Chee Loong, T. ve Idris, A. (2014). Rapid alkali catalyzed transesterification of microalgae lipids to biodiesel using simultaneous cooling and microwave heating and its optimization. *Bioresour. Technol.*, 174, 311–315.

- Connemann J. ve Fischer J. (1998). Biodiesel processing Technologies. The International Liquid Biofuels Congress, July 1998.
- Demir, C. (2006). Biyodizel Standartları ve Analiz Yöntemleri. *Biyoyakıt Dünyası Dergisi*, 1, 48-49.
- Diwani, G. E., Attia, N. K. ve Hawash, S. I. (2009). Development and evaluation of biodiesel fuel and by-products from jatropha oil. *International Journal of Environmental Science and Technology*, 6(2), 219–224.
- Eryılmaz, T. (2014). Yozgat İli Şartlarında Yetiştirilen Aspir (*Carthamus tinctorius* L.) Dinçer Çeşidinden Üretilen Biyodizelin Yakıt Özelliklerinin Belirlenmesi. *J. Agric. Fac. Gaziosmanpaşa Univ.*, 31(1), 62–75.
- Fariku, S., Ndonga, A.E. ve Bitrus, P.Y. (2010). Biofuel characteristics of beniseed ( *Sesamum indicum* ) oil. *African Journal of Biotechnology*, 6 (21), 2442-2443.
- Gnanaprakasam, A., Sivakumar, V.M., Surendhar, A., Thirumarimurugan, M. ve Kannadasan, T. (2013). Recent Strategy of Biodiesel Production from Waste Cooking Oil and Process Influencing Parameters: A Review. *Journal of Energy*, 2013, 10.
- Gupta, P. K., Kumar, R., Panesar, B. S. ve Thapar, V. K. (2007). Parametric studies on bio-diesel prepared from rice bran oil. *CIGR E-Journal*, 9, 1-12.
- Oguntola, A., Akintola, T.A., Enweremadu, C. ve Adeleke, A. (2008). Characterization of palm-Kernel oil biodiesel produced through NaOH-catalyzed transesterification process. *Scientific Research and Essay*, 3, 308-311.
- Özdemir, Z. Ö. ve Mutlubaş, H. (2016). Biyodizel Üretim Yöntemleri ve Çevresel Etkileri. *Kırklareli Üniversitesi Mühendislik ve Fen Bilimleri Dergisi*, 2(2), 129-143.
- Tan, R.R., Cluaba, A.B. ve Purvis, M.R.I. (2004). Carbon balance implications of coconut biodiesel utilization in the Philippine automotive transport sector. *Biomass and Bioenergy*, 26(6), 579-585.
- Tippayawong, N., Chumjai, P., ve Preparation, A. S. (2012). Characterization and Performance of Biofuel from Passion Fruit Processing Residues. 2, 24–27.
- Tshizanga N., Aransiola, E.F., Oyekola, O. (2017). Optimisation of biodiesel production from waste vegetable oil and eggshell ash. *South african journal of chemical engineering*. 23,145-156
- Torres, E.A., Cerqueira, G.S., Ferrer, T.M., Quintella, C.M., Raboni, M., Torretta, V., Urbini, G. (2013). Recovery of different waste vegetable oils for biodiesel production: A pilot experience in Bahia State, Brazil. *Waste Management*. 33, 2670–2674
- Ullah, F., Nosheen, A., Hussain, I. ve Bano, A. (2009). Base catalyzed transesterification of wild apricot kernel oil for biodiesel production. *African Journal of Biotechnology*, 8(14), 3289-3293.
- Zhenyi, C., Xing, J., Shuyuan, L. ve Li, L. (2004). Thermodynamics Calculation of the Pyrolysis of Vegetable Oils. *Energy Sources*, 26(9), 849–856.

**T.C**  
**SİVAS CUMHURİYET ÜNİVERSİTESİ**

**İLGİLİ MAKAMA**

26-27 Eylül 2023 tarihlerinde Üniversitemizde düzenlenecek olan 2. Uluslararası Enerji Günleri Kongresi düzenleme kuruluna aşağıda unvanları ve isimleri yazılı olan akademisyenler görevlendirilmiştir.

  
**Prof. Dr. Alim YILDIZ**  
**Rektör**

**Düzenleme Kurulu Başkanı**

Dr. Öğr. Üyesi Derya Betül ÜNSAL ÇELİMLİ, Sivas Cumhuriyet University, Turkey

**Düzenleme Kurulu Üyeleri**

Prof. Dr. Nevcihan GÜRSOY, Sivas Cumhuriyet University, Turkey

Prof. Dr. Meltem SARIOĞLU CEBEÇİ, Sivas Cumhuriyet University, Turkey

Assoc. Prof. Dr. Ahmet AKSÖZ, Sivas Cumhuriyet University, Turkey

Assoc. Prof. Dr. Sultan ERKAN, Vice Director of Renewable Energy Research Center, Sivas Cumhuriyet University, Turkey

Dr. Mustafa Latif EMEK, İktisadi Kalkınma ve Sosyal Araştırmalar Enstitüsü